



PRODUCT GUIDE 2023 - 2024



Trust[®] offers a wide range of innovative products to meet all of your commercial cleaning needs. These products are high quality and offer excellent cleaning performance. From waste disposal, cleaning and material delivery to food service and safety management; Trust[®] offers you a full range of solutions.

**No matter what you clean,
we are the brand you can**



Innovative Solutions

Our innovative products are designed to meet all of your needs and to enhance productivity in your workplace.



Total Quality Control

Our products have been rigorously tested and perform with industry-leading durability.





ENVIRONMENTAL SUSTAINABILITY A Green Future

At TRUST we strive to be environmentally friendly and stand by strict environmental standards and business practices. We align with environmental protection agencies and organizations in the pursuit of environmental sustainability. Our research and product innovation has led to the effective reduction of our carbon footprint in the manufacturing of commercial products.

Our vision is to provide comprehensive working solutions of high quality. By helping people in workplaces all around the world our products improve lives and help protect the environment. Environmental sustainability and environmental responsibility are at the core of our operations.

Creation of safe, sustainable products - At Trust we design, manufacture and market green products with environmentally friendly practices in place to protect, conserve, and sustain the world's natural resources.

Incorporating environmental principles into our partnerships – Our green vision leads us to collaborate in our business partnerships in seeking a green future.

We will continue to keep our clients up-to-date with our efforts and progress.



8 | WASTE

- 10** | All-purpose Containers
- 16** | Indoor Containers
- 28** | Recycling Containers
- 40** | Medical Waste Management
- 42** | Decoration Waste Containers
- 60** | Accessories



64 | CLEANING

- 68** | Cleaning Carts
- 78** | Cleaning Cart Combination
- 84** | Mopping Systems
- 92** | Wet Mops
- 100** | Wet Mop Handles
- 102** | Dust Mops
- 106** | Microfiber Cleaning System
- 112** | Brooms and Brushes
- 126** | Dust Pans
- 128** | Floor Squeegees
- 130** | Dusting Tools
- 132** | Auxiliary Cleaning Tools
- 140** | Washroom



144 | MATERIAL HANDLING

- 146** | Mobile Work Centers
- 152** | Platform Trucks
- 158** | Cube Trucks
- 160** | Tilt Trucks
- 164** | Utility Service Carts
- 170** | Storage and Organization
- 176** | Container Tools



180 | FOODSERVICE

- 184** | Food Storages
- 218** | Insulated Products
- 230** | Transport
- 242** | Food Preparations
- 244** | Dishwashing and Storage
- 254** | Tote Boxes
- 256** | Youth Products
- 260** | Cleaning Tools



266 | SAFETY

- 268** | Safety Signs
- 270** | Safety Cones and Accessories

6 | LEGEND

6 | COLOR GUIDE

7 | CERTIFICATIONS

274 | PRODUCT INDEX

317 | COMPONENT INDEX

327 | DISHWASING RACK GUIDE

LEGEND



Assembly is required.



Hands free, reduce the risk of exposure to dirt.



Motorized with intelligent control system.



Color-coded cleaning system.

Please select the proper color-coded equipment depending on the area to prevent cross-contamination.

Blue: For general cleaning, such as office and lobby.

Yellow: For general cleaning of the bathroom area.

Red: For cleaning high cross-contamination areas, such as toilet and bathroom.

Green: For cleaning food service facilities, such as diningroom, kitchen, and canteen.



UV absorber is added to extend the service life in outdoor applications.



BPA free

Eastman Tritan copolyester does not contain the toxic chemical bisphenol-A (BPA) and its use can help to increase food safety.

Studies have shown that Bisphenol-A is harmful to human health. Components used in plastics, such as bisphenol-A (BPA) are released from plastic products, and are known as endocrine-disrupting compounds (EDCs) owing to their ability to modulate the endocrine system.



Cadmium free

Exposure to cadmium is known to be toxic, and is linked to an increased risk for cancer as well as a number of kidney and liver afflictions.



Dishwasher safe

COLOR GUIDE

| | | | | | |
|------------------------------|------------------------------|-------------------------------------|----------------------------------|-------------------------------|---------------------------------|
| | | | | | |
| Amber AMBR | Ashtree ASH | Beige BEIG | Black BLA | Blue BLUE | Brown BRN |
| | | | | | |
| Brown Stone BSTONE | Clear CLR | Coral CORL | Crimson CR | Dark Brown DBRN | Dark Gray DGRAY |
| | | | | | |
| Empire Green EGRN | Golden Yellow GLD | Gray GRAY | Green GRN | Indigo Blue IND | Lacquer LAC |
| | | | | | |
| Light Beige LBEIG | Light Brown LBRN | Light Gray LGRAY | Light Platinum LPLAT | Light Red LRED | Metallic Silver MSILV |
| | | | | | |
| Natural NAT | Off White OWHT | Orange ORA | Platinum PLAT | Red RED | Reddish Brown RBRN |
| | | | | | |
| River Rock ROCK | Sage Green SGRN | Satin Stainless Steel SSS | Semi-transparent STRAN | Speckled Gray SGRAY | Stainless Steel SS |
| | | | | | |
| Titanium Gold TITA | Verdant Green VGRN | Walnut WAL | White WHT | Yellow YEL | |

CERTIFICATES



ISO-international Organization for Standardization

ISO9001-2001 is an internationally recognized quality management system that provides:

1. Guidance for businesses that want to implement or improve quality systems within their business.
2. Benchmarks that customers can use to evaluate an organization's quality system.
3. Represents a commitment to continuous value improvement.

ISO 14000 is a family of standards to plan, implement, inspect and review environment management and operation system to enhance the environment protection:

1. Promote the implementation of environmental management regulations and systems.
2. Promote the improvement of environmental management within the business.
3. Promote the harmonious development of environment and economy.



ASTM Certification

ASTM F404 is the American Society for Testing and Materials' safety standard for evaluating a High Chair. TRUST youth seat has been approved in ASTM F404 testing.

ASTM F2285 is an American Society for Testing and Materials' safety performance specification that establishes performance requirements, test methods, and labeling requirements to minimize the hazards to children presented by Diaper Changing Tables for commercial use with children up to 22.7KG. TRUST baby changing station passed the ASTM F2285 testing.



QS Certification

Quality Safety. TRUST has been granted a QS production license certificate.



HACCP Certification

Hazard Analysis and Critical Control Points is a systematic method using principles (Food Hygiene Practices) for analyzing food process and determining the possible chemical, physical, and biological hazards within that process that should prevent any unsafe food from leaving the process.



FDA Certification

Under regulations administered by the U.S. Food and Drug Administration (FDA), this product, as supplied by Eastman Chemical Company, may lawfully be used on the basis of 21 CFR 174.5(d)(5) as a component in the manufacture of repeated use food-contact articles as described in Food Contact Notification No.729. The finished food contact article containing this polymer is intended to contact all types of food at temperatures up to and including 100°C for definitions of food types, refer to Tables 1 and 2 at website <http://www.fda.gov/Food/FoodIngredientsPackaging/FoodContactSubstancesFCS/default.htm>. This formulation

contains a proprietary additive which complies with the regulations for indirect food additives published by the U.S. Food and Drug Administration. In addition, the general provisions for indirect food additives in 21 CFR 174.5 are applicable to the use of this product.



China Environmental Labeling

China Environmental Labeling Product Certification is the most authoritative certification of green products and environmental friendly products in China, to recognize the product quality and environmental performance and confirm that the products meet the national standards for environmental protection requirements on behalf of the government.



UL Certification

Underwriters Laboratory (UL) approved containers (1261/1262 /1263/1264) , up to UL94-2010 standard, while rated to be V0.



NSF Certification

NSF (National Sanitation Foundation) is committed to standards development, product testing and certification services in the fields of public sanitation and security. It's a widely recognized leading global provider of public health and security certification.



ISTA-international Safe Transit Association

TRUST has ISTA-certified laboratory for testing and certification of transport packaging.



EU Certification

The EU issued directive 1935/2004 for substances in contact with food. The purpose of this directive is to ensure that materials and substances in contact with food directly or indirectly is safe to the consumers both in design and structure. The TRUST food storage box (3011/3012) has been proved safe by relevant EU tests.



TÜV Certification

TÜV is a security authentication marks which Germany TÜV specially made for components products. It has been widely accepted in Germany and Europe. The purpose of safety standards is to prevent household electrical products, mechanical products, automobile products causing the danger personal injury and property damage during the using process.



GS Certification

GS is the meaning of "German Geprüfte Sicherheit" (security certification).GS is recognized by European market as German security authentication marks, which based on German product safety(GPGS), and it is also a voluntary certification according to the European standard EN or German industrial standards DIN testing. TRUST multi-purpose draw ladder (6945/6946) passed GS testing.



ALL-PURPOSE CONTAINERS

Thor® Containers and Accessories 10
 Thor® Rollout Containers 12

INDOOR CONTAINERS

Svelte® Containers and Accessories 16
 Waste Classification Symbols 20
 Step-on Containers 21
 Rigid Liners for Step-On Containers 21
 Thor® Step-On Rollout Containers 24
 Hands-free Containers 25
 Soft Wastebaskets 26
 Unfire® Fire-resistant Wastebaskets 26
 Steel Mesh Bins 27
 Stainless Steel Trash Cans 27

RECYCLING CONTAINERS

Thor® Recycling Containers and Accessories 29
 Svelte® Recycling Containers and Accessories 30

Svelte® Waste Sorting System 31
 Waste Sorting System 35
 Thor® Waste Sorting System 36
 Rollout Recycling Bins 37
 Riston® Outdoor Recycling Containers 38
 Deskside Recycling Containers 38

MEDICAL WASTE MANAGEMENT

Thor® Medical Containers 41
 Medical Step-on Containers 41

DECORATIVE WASTE CONTAINERS

Rockface® Containers and Faceplates 43
 Steeledge® Containers 45
 Aluminum Trash Cans 47
 Open Trash Cans 48
 Step-on Containers 48
 Svelte® Stainless Steel Step-on Containers 50
 Neatace® Classic Trash Cans 51

Riston® Decorative Containers 52
 Beaucan® Outdoor Decorative Trash Cans 52
 Terminator® Cigarette Butt Buckets 54
 Steeledge® Cigarette Barrels 58

ACCESSORIES

Thor® Accessories 60
 Carry Caddies 61
 Signboard Hooks 61
 Svelte® Accessories 62
 Waste Classification Symbols 63



Perfect Waste Management System

We provide a highly efficient, low-cost waste management system. Our products are made of high quality material with a sturdy structure to prolong their life.

Cost-Efficient

Our waste collection and transport solutions offer productivity gains - reducing the time taken for repetitive tasks.

Sustainable Development

All our plastic containers are 100% recyclable.

Multiple Solutions

We provide products of various sizes, colors and materials, designed to deliver practical waste solutions for diverse areas across the workplace.



ALL-PURPOSE CONTAINERS



THOR® ROUND CONTAINERS

PRODUCT FEATURES:

1. All-plastic construction will not rust, chip, or peel; resists dents.
2. Ergonomic handles that are smooth and comfortable.
3. Reinforced rims increase strength and durability.
4. Comes with four trash liner grooves for easy attachment without the need to tie knots.
5. Four vent channels provide 50% less worker exertion when lifting a filled trash liner compared with a traditional container.
6. Bottom hand grips of 30 mm width assist in emptying.
7. Double-ribbed base increases stability and dragging capacity.



Ergonomic handles with trash liner grooves for easy attachment without the need to tie knots



Double-ribbed base with 30mm wide Bottom hand-grips



Reinforced rims increase strength and durability



Four vent channels provide 50% less worker exertion when lifting a filled trash liner compared with a traditional container

| Model | Description | Dimensions | Capacity | Color | Pack |
|-------|-----------------------|---------------|----------|--|------|
| 1009 | THOR® Round Container | 33.5 × 38.7cm | 23L | BLUE, GRAY, WHT, YEL, GRN, RED, BRN | 6 |
| 1011 | THOR® Round Container | 40.0 × 44.0cm | 38L | BLUE, GRAY, WHT, YEL, GRN, RED, BRN | 6 |
| 1010 | THOR® Round Container | 47.0 × 54.5cm | 60L | BLUE, GRAY, WHT, YEL, GRN, RED | 6 |
| 1012 | THOR® Round Container | 49.0 × 57.0cm | 75L | BLUE, GRAY, WHT, YEL, GRN, RED, BLA, BRN | 6 |
| 1013 | THOR® Round Container | 56.0 × 70.0cm | 121L | BLUE, GRAY, WHT, YEL, GRN, RED, BLA, BRN | 6 |
| 1014 | THOR® Round Container | 61.0 × 80.0cm | 166L | BLUE, GRAY, WHT, YEL, GRN, RED, BLA | 4 |
| 1015 | THOR® Round Container | 67.0 × 84.0cm | 208L | BLUE, GRAY, WHT, YEL, GRN, RED, BLA | 3 |

THOR® FUNNEL TOPS

PRODUCT FEATURES:

1. Made of tough and durable plastic.
2. Smooth surface for easy cleaning.
3. Hands-free funnel top, easier access for waste.

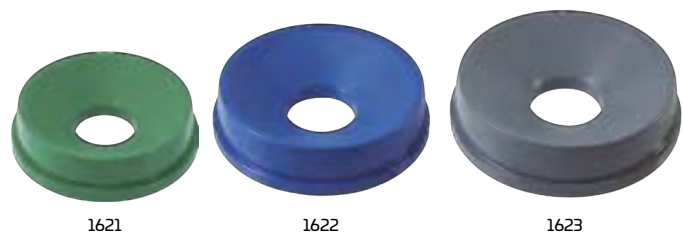

| Model | Description | Dimensions | Capacity | Color | Pack |
|-------|---------------------------|---------------|----------|-----------------|------|
| 1621 | THOR® Funnel Top for 1011 | 40.4 × 9.9cm | N/A | BLUE, GRAY, GRN | 6 |
| 1622 | THOR® Funnel Top for 1012 | 50.0 × 11.5cm | N/A | BLUE, GRAY, GRN | 6 |
| 1623 | THOR® Funnel Top for 1013 | 56.8 × 12.9cm | N/A | BLUE, GRAY, GRN | 4 |



THOR® ROUND TOPS

PRODUCT FEATURES:

1. Choice of colored lids.
2. Strong, snap-on lids for secure, stable stacking.
3. 1633, 1634 made of structural web molded plastic to ensure higher durability and toughness.



| Model | Description | Dimensions | Capacity | Color | Pack |
|-------|---|---------------|----------|--|------|
| 1609 | THOR® Lid for 1009 | 34.7 × 3.8cm | N/A | BLUE, GRAY, WHT, YEL, GRN, RED, BLA, BRN | 6 |
| 1610 | THOR® Lid for 1010 | 48.2 × 5.9cm | N/A | BLUE, GRAY, WHT, YEL, GRN, RED | 6 |
| 1611 | THOR® Lid for 1011 | 40.6 × 5.2cm | N/A | BLUE, GRAY, WHT, YEL, GRN, RED, BLA, BRN | 6 |
| 1612 | THOR® Lid for 1012 | 50.7 × 6.6cm | N/A | BLUE, GRAY, WHT, YEL, GRN, RED, BLA, BRN | 6 |
| 1613 | THOR® Lid for 1013 | 57.0 × 5.9cm | N/A | BLUE, GRAY, WHT, YEL, GRN, RED, BLA, BRN | 6 |
| 1614 | THOR® Lid for 1014 | 62.2 × 6.0cm | N/A | BLUE, GRAY, WHT, YEL, GRN, RED, BLA | 4 |
| 1615 | THOR® Lid for 1015 | 68.0 × 6.6cm | N/A | GRAY | 3 |
| 1633 | THOR® Round Top for 1013 | 57.6 × 31.1cm | N/A | GRAY, RED | 1 |
| 1634 | THOR® Round Top with an ashtray for 1013 | 57.6 × 31.1cm | N/A | GRAY, RED | 1 |
| 1635 | THOR® Bottle and Can Recycling Top for 1013 | 57.2 × 10.0cm | N/A | BLUE, GRN | 6 |
| 1636 | THOR® Paper Recycling Top for 1013 | 57.2 × 10.0cm | N/A | BLUE, GRN | 6 |
| 1637 | THOR® Single Stream Recycling Top for 1013 | 57.2 × 10.0cm | N/A | BLUE, GRN | 6 |



THOR® DOLLIES

PRODUCT FEATURES:

1. Easy mobility and maneuverability of heavy loads.
2. Swivel casters offer easy mobility.
3. Attach trash containers with ease.
4. Sturdy structural foam construction won't rust, dent, chip, or peel.
5. 1819 can easily transport 1015 and steel drums.



| Model | Description | Dimensions | Capacity | Color | Pack |
|-------|--|-----------------------|----------|-------|------|
| 1811 | THOR® Dolly for 1010/1012/1013/1014/1015 | 46.4 × 16.8cm | N/A | BLA | 2 |
| 1813 | THOR® Quiet Dolly for 1010/ 1012/1013/1014/1015 | 46.4 × 16.8cm | N/A | BLA | 2 |
| 1818 | THOR® Drum Dolly for 1010/1012/ 1013/1014/1015/1231/1233 | 114.3 × 51.4 × 20.3cm | N/A | BLA | 1 |
| 1819 | THOR® Universal Drum Dolly | 61.9 × 18.1cm | N/A | BLA | 2 |

THOR® SQUARE CONTAINERS



PRODUCT FEATURES:

1. Square shape offers up to 27% more capacity than round containers.
2. Ergonomic handles that are smooth and comfortable.
3. Reinforced rims add strength and durability.
4. Thick walls up to 4 mm add strength and durability.
5. Bottom hand grips of 30 mm width assist in emptying.
6. Tight fitting lids help protect the contents.
7. Square dollies are available to ensure easy mobility and maneuverability of heavy loads.



1231

1233



Equipped with **ergonomic handles** that are smooth and comfortable



Bottom hand grips of 30 mm width assist in emptying



Tight fitting lids help protect the contents. Lids allow for stable stacking to save space



Square dollies are available to ensure easy mobility and maneuverability of heavy loads

| Model | Description | Dimensions | Capacity | Color | Pack |
|-------|------------------------|----------------------|----------|----------------|------|
| 1231 | THOR® Square Container | 54.6 × 54.6 × 57.2cm | 106L | GRAY, WHT, RED | 6 |
| 1233 | THOR® Square Container | 59.7 × 59.7 × 73.0cm | 150L | GRAY, WHT | 4 |
| TOPS | | | | | |
| 1661 | THOR® Lid for 1231 | 55.9 × 55.9 × 5.1cm | N/A | GRAY, WHT, RED | 6 |
| 1663 | THOR® Lid for 1233 | 61.0 × 61.0 × 5.1cm | N/A | GRAY, WHT | 4 |

THOR® ROLLOUT CONTAINERS



PRODUCT FEATURES:

1. Heavy-duty 20cm wheels allow easy mobility, even over steps or curbstone.
2. Attached hinged lid fits securely; swings back and locks.
3. Molded-in axle retainer adds strength.
4. Inset wheel position helps prevent damage to walls and doorways.
5. 1025 is rotomolded, designed for holding a large volume of refuse. Its one-piece structure offers extraordinary strength and durability.



1021

1025

| Model | Description | Dimensions | Capacity | Color | Pack |
|-------|-------------------------|-----------------------|----------|---------------------------|------|
| 1021 | THOR® Rollout Container | 72.4 × 59.4 × 92.7cm | 190L | BLUE, GRAY, YEL, GRN, RED | 2 |
| 1025 | THOR® Rollout Container | 69.7 × 93.4 × 121.4cm | 360L | GRAY, RED | 1 |

THOR® ROLLOUT CONTAINERS



PRODUCT FEATURES:

1. Suitable for various commercial environments.
2. Heavy-duty 20cm wheels allow easy mobility, even over steps or curbstone.
3. Hinged lids close tightly and can be locked when fully lifted to prevent swinging during transport.
4. Inset wheel position helps prevent damage to walls and doorways.
5. Ergonomic handle, more flexible control.
6. Smooth surface for easy cleaning.
7. Reinforced rims add strength and durability.
8. 1033/1034 is rotomolded, designed for holding large a volume of refuse. Its one-piece structure offers extraordinary strength and durability.



1031

1033

| Model | Description | Dimensions | Capacity | Color | Pack |
|-------|-------------------------|-----------------------|----------|--------------------------------|------|
| 1031 | THOR® Rollout Container | 52.0 × 66.3 × 94.0cm | 120L | BLUE, GRAY, YEL, GRN, RED, BLA | 2 |
| 1032 | THOR® Rollout Container | 62.1 × 72.8 × 100.5cm | 190L | BLUE, GRAY, YEL, GRN, RED, BLA | 2 |
| 1033 | THOR® Rollout Container | 64.5 × 76.0 × 115.0cm | 240L | BLUE, GRAY, YEL, GRN, RED, BLA | 1 |
| 1034 | THOR® Rollout Container | 72.7 × 94.9 × 117.0cm | 360L | BLUE, GRAY, YEL, GRN, RED, BLA | 1 |

THOR® ROLLOUT CONTAINERS WITH CASTERS



PRODUCT FEATURES:

1. Suitable for various commercial environments.
2. Heavy-duty 20cm wheels allow easy mobility, even over steps or curbstone.
3. Hinged lids close tightly and can be locked when fully lifted to prevent swinging during transport.
4. Ergonomic handle, more flexible control.
5. Smooth surface for easy cleaning.
6. Reinforced rims add strength and durability.
7. 1043/1044 is rotomolded, designed for holding a large volume of refuse. Its one-piece structure offers extraordinary strength and durability.
8. Front swivel casters with brake enable for enhanced maneuverability. Embedded castors designed to avoid damage caused by collisions with walls and doorways.



1041

1043

| Model | Description | Dimensions | Capacity | Color | Pack |
|-------|--------------------------------------|-----------------------|----------|--------------------------------|------|
| 1041 | THOR® Rollout Container with Casters | 52.0 × 66.3 × 94.0cm | 120L | BLUE, GRAY, YEL, GRN, RED, BLA | 2 |
| 1042 | THOR® Rollout Container with Casters | 62.1 × 72.8 × 100.5cm | 190L | BLUE, GRAY, YEL, GRN, RED, BLA | 2 |
| 1043 | THOR® Rollout Container with Casters | 64.5 × 76.0 × 115.0cm | 240L | BLUE, GRAY, YEL, GRN, RED, BLA | 1 |
| 1044 | THOR® Rollout Container with Casters | 72.7 × 94.9 × 117.0cm | 360L | BLUE, GRAY, YEL, GRN, RED, BLA | 1 |



THOR® STEP-ON ROLLOUT CONTAINERS

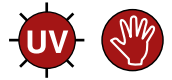

PRODUCT FEATURES:

1. Suitable for various commercial environments.
2. Hands-free, improves work efficiency.
3. Heavy-duty 20cm wheels allow easy mobility, even over steps or curbstone.
4. Hinged lids close tightly and can be locked when fully lifted to prevent swinging during transport.
5. Inset wheel position helps prevent damage to walls and doorways.
6. Ergonomic handle, more flexible control.
7. Smooth surface for easy cleaning.
8. Reinforced rims add strength and durability.
9. Soft-close lid prevents noise effectively.
10. 1037/1038 is rotomolded, designed for holding a large volume of refuse. Its one-piece structure offers extraordinary strength and durability.



1035

1037

| Model | Description | Dimensions | Capacity | Color | Pack |
|-------|---------------------------------|-----------------------|----------|--------------------------------|------|
| 1035 | THOR® Step-On Rollout Container | 52.0 × 66.3 × 94.0cm | 120L | BLUE, GRAY, YEL, GRN, RED, BLA | 1 |
| 1036 | THOR® Step-On Rollout Container | 62.1 × 72.8 × 100.5cm | 190L | BLUE, GRAY, YEL, GRN, RED, BLA | 1 |
| 1037 | THOR® Step-On Rollout Container | 64.5 × 76.0 × 115.0cm | 240L | BLUE, GRAY, YEL, GRN, RED, BLA | 1 |
| 1038 | THOR® Step-On Rollout Container | 72.7 × 94.9 × 117.0cm | 360L | BLUE, GRAY, YEL, GRN, RED, BLA | 1 |

THOR® STEP-ON ROLLOUT CONTAINERS WITH CASTERS

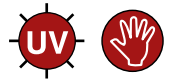

PRODUCT FEATURES:

1. Suitable for various commercial environments.
2. Hands-free, improves work efficiency.
3. Heavy-duty 20cm wheels allow easy mobility, even over steps or curbstone.
4. Hinged lids close tightly and can be locked when fully lifted to prevent swinging during transport.
5. Ergonomic handle, more flexible control.
6. Smooth surface for easy cleaning.
7. Reinforced rims add strength and durability.
8. Soft-close lid prevents noise effectively.
9. 1047/1048 is rotomolded, designed for holding a large volume of refuse. Its one-piece structure offers extraordinary strength and durability.
10. Front swivel casters with brake enable for enhanced maneuverability. Embedded castor design avoids damage caused by collisions with walls and doorways.



1045

1047

| Model | Description | Dimensions | Capacity | Color | Pack |
|-------|--|-----------------------|----------|--------------------------------|------|
| 1045 | THOR® Step-On Rollout Container with Casters | 52.0 × 66.3 × 94.0cm | 120L | BLUE, GRAY, YEL, GRN, RED, BLA | 1 |
| 1046 | THOR® Step-On Rollout Container with Casters | 62.1 × 72.8 × 100.5cm | 190L | BLUE, GRAY, YEL, GRN, RED, BLA | 1 |
| 1047 | THOR® Step-On Rollout Container with Casters | 64.5 × 76.0 × 115.0cm | 240L | BLUE, GRAY, YEL, GRN, RED, BLA | 1 |
| 1048 | THOR® Step-On Rollout Container with Casters | 72.7 × 94.9 × 117.0cm | 360L | BLUE, GRAY, YEL, GRN, RED, BLA | 1 |

THOR. CONTAINERS can be configured with a variety of tops and dollies to suit any need.





SVELTE® CONTAINERS



PRODUCT FEATURES:

1. Our products are made of high quality material with a sturdy structure to prolong life.
2. The slim rectangle shape is space efficient and fits tight spaces.
3. Vent channels are designed for easy lifting of a filled trash liner with less exertion.
4. Ergonomic handles that are smooth and comfortable.
5. Comes with four trash liner grooves for easy attachment without the need to tie knots.
6. Bottom hand-holds assist in emptying.
7. Multiple interchangeable tops are available to suit various applications.
8. Custom imprinting available.



1215



1215/1216



Bottom hand-holds assist with emptying



Comes with four trash liner grooves for easy attachment without the need to tie knots



Optional Caster Set (1216), for easier movement

| Model | Description | Dimensions | Capacity | Color | Pack |
|-------|---------------------|----------------------|----------|---|------|
| 1215 | SVELTE® Container | 49.9 × 24.9 × 63.0cm | 46L | BLUE, GRAY, YEL, GRN, RED, BLA, BRN, BEIG | 4 |
| 1216 | Caster Set for 1215 | N/A | N/A | BLA | 1 |



SVELTE® TOPS

PRODUCT FEATURES:

1. Interchangeable, color-coded tops promote waste separation.
2. Slotted blue top for paper.
3. Green and blue round-hole tops for glass bottles, glass jars, and metal cans.
4. Gray handle top for general refuse.
5. 1651 is sturdy and easy to cover. It is stackable and can be placed on its edge for easy storage.



1647



1648



1649



1650



1651



Svelte® Lockable Lid for 1215 ensures goods safety



Svelte® Lockable Lid for 1215 can be placed on the edge for easy storage

| Model | Description | Dimensions | Capacity | Color | Pack |
|-------|---|---------------------|----------|----------------------------|------|
| 1647 | SVELTE® Bottle and Can Recycling Top for 1215 | 45.2 × 25.8 × 6.2cm | N/A | BLUE, GRN | 4 |
| 1648 | SVELTE® Paper Recycling Top for 1215 | 45.2 × 25.8 × 6.2cm | N/A | BLUE | 4 |
| 1649 | SVELTE® Handle Top for 1215 | 45.2 × 25.8 × 6.2cm | N/A | LGRAY | 4 |
| 1650 | SVELTE® Swing Lid for 1215 | 45.4 × 25.9 × 8.0cm | N/A | BLUE, GRAY, GRN, BLA, BEIG | 4 |
| 1651 | SVELTE® Lockable Lid for 1215 | 48.0 × 26.0 × 5.5cm | N/A | BLUE, GRAY, GRN, BLA, BEIG | 4 |



SVELTE® CONTAINERS



PRODUCT FEATURES:

1. Our products are made of high quality material and with a sturdy structure designed to prolong life.
2. The slim rectangle shape is optimized to fit tight spaces.
3. Vent channels are designed for easy lifting of a filled trash liner with less exertion.
4. Comes with ergonomic handles that are smooth and comfortable.
5. 1220 has an inset handle to save space.
6. Comes with four trash liner grooves for easy attachment without the need to tie knots.
7. Bottom hand-holds assist in emptying.
8. Multiple interchangeable tops are available to suit various applications.
9. Custom imprinting available.



Bottom hand-holds assist in emptying



Comes with four trash liner grooves for easy attachment without the need to tie knots



1220 has an inset handle to save space

| Model | Description | Dimensions | Capacity | Color | Pack |
|-------|-------------------|----------------------|----------|---|------|
| 1211 | SVELTE® Container | 57.0 × 27.2 × 63.2cm | 60L | BLUE, GRAY, YEL, GRN, RED, BLA, BRN, BEIG | 4 |
| 1213 | SVELTE® Container | 57.0 × 27.2 × 75.6cm | 87L | BLUE, GRAY, YEL, GRN, RED, BLA, BRN, BEIG | 4 |
| 1220 | SVELTE® Container | 51.3 × 27.2 × 75.6cm | 87L | BLUE, GRAY, YEL, GRN, RED, BLA, BRN, BEIG | 4 |

SVELTE® TOPS



PRODUCT FEATURES:

1. Interchangeable, color-coded tops promote waste separation.
2. Slotted blue top for paper.
3. Green and blue round-hole tops for glass bottles, glass jars, and metal cans.
4. Gray handle top for general refuse.



1641



1642



1643



1644



1645



1646

| Model | Description | Dimensions | Capacity | Color | Pack |
|-------|--------------------------------------|----------------------|----------|-------------------------------------|------|
| 1641 | SVELTE® Bottle and Can Recycling Top | 52.3 × 28.8 × 6.7cm | N/A | BLUE, GRAY, YEL, GRN, RED, BLA, BRN | 4 |
| 1642 | SVELTE® Paper Recycling Top | 52.3 × 28.8 × 6.7cm | N/A | BLUE, GRN, RED | 4 |
| 1643 | SVELTE® Handle Top | 52.3 × 28.8 × 7.0cm | N/A | LGRAY | 4 |
| 1644 | SVELTE® Swing Lid | 52.3 × 28.8 × 11.5cm | N/A | BLUE, GRAY, GRN, BLA, BEIG | 4 |
| 1645 | SVELTE® Connect Valve Style Lid | 54.8 × 32.5 × 4.0cm | N/A | BLA | 4 |
| 1646 | SVELTE® Single Stream Recycling Top | 52.3 × 28.8 × 6.7cm | N/A | GRN | 4 |



SVELTE® DOLLIES

PRODUCT FEATURES:

1. Sturdy structural foam construction will not rust, dent or chip.
2. 7.5cm non-marking casters.
3. Easy mobility and maneuverability of heavy loads.
4. Multi-compartment dollies can easily move multiple containers and facilitate waste classification.



1814



1213/1815



| Model | Description | Dimensions | Capacity | Color | Pack |
|-------|---|-----------------------|----------|-------|------|
| 1814 | SVELTE® Dolly, for 1211/1212/1213/1214/1220/1221 | 51.6 × 29.0 × 26.0cm | N/A | BLA | 2 |
| 1815 | SVELTE® Double-compartment Dolly, for 1211/1212/1213/1214/1220/1221 | 58.2 × 51.7 × 24.0cm | N/A | BLA | 1 |
| 1816 | SVELTE® Tri-compartment Dolly, for 1211/1212/1213/1214/1220/1221 | 87.3 × 51.7 × 24.0cm | N/A | BLA | 1 |
| 1817 | SVELTE® Four-compartment Dolly, for 1211/1212/1213/1214/1220/1221 | 116.4 × 51.7 × 24.0cm | N/A | BLA | 1 |

WASTE CLASSIFICATION SYMBOLS



PRODUCT FEATURES:

1. Helpful for waste classification.
2. Self-adhesive PVC sticker, easy to attach and scrub-resistant.

| Model | Description | Dimensions | Pack |
|-------|--|---------------|------|
| 1940 | "Recyclable Waste" Label | 13.0 × 23.0cm | 10 |
| 1941 | "Soil" Label | 13.0 × 23.0cm | 10 |
| 1942 | "Building Materials" Label | 13.0 × 23.0cm | 10 |
| 1943 | "Garden Waste" Label | 13.0 × 23.0cm | 10 |
| 1944 | "Food Waste" Label | 13.0 × 23.0cm | 10 |
| 1945 | "Paint" Label | 13.0 × 23.0cm | 10 |
| 1946 | "Household and Garden Chemicals" Label | 13.0 × 23.0cm | 10 |
| 1947 | "Mixed Paper and Card" Label | 13.0 × 23.0cm | 10 |
| 1948 | "Plastics" Label | 13.0 × 23.0cm | 10 |
| 1949 | "Mixed Textiles and Clothes" Label | 13.0 × 23.0cm | 10 |
| 1950 | "Mixed Glass" Label | 13.0 × 23.0cm | 10 |
| 1951 | "Metal" Label | 13.0 × 23.0cm | 10 |
| 1952 | "Batteries" Label | 13.0 × 23.0cm | 10 |



Helpful for waste classification and management.



STEP-ON CONTAINERS

PRODUCT FEATURES:

1. Tight-fitting lid helps contain odors and prevents insects such as house flies from entering.
2. Tough, puncture-resistant, all-plastic construction, resistant to damage or dents.
3. Quiet, heavy-duty pedal for hands-free hygienic use.
4. Soft-close lid prevents noise effectively.
5. Optional leak-proof rigid liners are available to contain liquid.



Soft-close lid prevents noise effectively



| Model | Description | Dimensions | Capacity | Color | Pack |
|-------|---------------------------|----------------------|----------|---------------------------|------|
| 1251 | Step-on Container | 33.7 × 32.4 × 40.2cm | 17L | BLUE, WHT, YEL, RED, BEIG | 1 |
| 1252 | Step-on Container | 41.3 × 40.0 × 43.5cm | 30L | BLUE, WHT, YEL, RED, BEIG | 1 |
| 1253 | Step-on Container | 41.3 × 40.0 × 60.0cm | 45L | BLUE, WHT, YEL, RED, BEIG | 1 |
| 1254 | Step-on Container | 50.2 × 41.0 × 67.3cm | 68L | BLUE, WHT, YEL, RED, BEIG | 1 |
| 1255 | Rollout Step-on Container | 50.2 × 44.7 × 82.6cm | 87L | BLUE, WHT, YEL, RED, BEIG | 1 |

RIGID LINERS FOR STEP-ON CONTAINERS

PRODUCT FEATURES:

1. Helps prolong the life of your containers.
2. Durable plastic construction with smooth surfaces for easy cleaning.
3. Recessed hand grips are available for lifting and emptying.



| Model | Description | Dimensions | Capacity | Color | Pack |
|-------|----------------------|----------------------|----------|-------|------|
| 1411 | Rigid Liner for 1251 | 28.6 × 22.5 × 32.0cm | 14L | GRAY | 2 |
| 1412 | Rigid Liner for 1252 | 36.5 × 29.8 × 33.7cm | 27L | GRAY | 2 |
| 1413 | Rigid Liner for 1253 | 36.5 × 29.8 × 50.2cm | 38L | GRAY | 2 |
| 1414 | Rigid Liner for 1254 | 45.7 × 31.1 × 55.9cm | 56L | GRAY | 4 |
| 1415 | Rigid Liner for 1255 | 45.7 × 31.1 × 72.4cm | 72L | GRAY | 4 |

SVELTE® STEP-ON CONTAINERS WITH FRONT PEDAL



PRODUCT FEATURES:

1. Our products are made of high quality material and have a sturdy structure to prolong life.
2. Tough, puncture-resistant, all-plastic construction, resistant to damage or dents.
3. The slim rectangle shape is optimized to fit tight spaces.
4. Quiet, heavy-duty pedal for hands-free hygienic use.
5. Soft-close lid prevents noise effectively.
6. Hold liquid with standard rigid liner.
7. Caster for 1309 for easy movement.



| Model | Description | Dimensions | Capacity | Color | Pack |
|-------|---------------------------|----------------------|----------|---|------|
| 1305 | SVELTE® Step-on Container | 37.7 × 23.0 × 39.9cm | 15L | BLUE, GRAY, WHT, YEL, GRN, RED, BLA, BEIG | 1 |
| 1306 | SVELTE® Step-on Container | 42.5 × 27.1 × 53.6cm | 30L | BLUE, GRAY, WHT, YEL, GRN, RED, BLA, BEIG | 1 |
| 1307 | SVELTE® Step-on Container | 45.6 × 29.2 × 71.9cm | 50L | BLUE, GRAY, WHT, YEL, GRN, RED, BLA, BEIG | 1 |
| 1308 | SVELTE® Step-on Container | 50.0 × 31.1 × 80.3cm | 68L | BLUE, GRAY, WHT, YEL, GRN, RED, BLA, BEIG | 1 |
| 1309 | SVELTE® Step-on Container | 57.0 × 35.3 × 82.6cm | 90L | BLUE, GRAY, WHT, YEL, GRN, RED, BLA, BEIG | 1 |

RIGID LINERS FOR SVELTE® STEP-ON CONTAINERS WITH FRONT PEDAL

PRODUCT FEATURES:

1. Helps prolong the life of your containers.
2. Durable plastic construction with smooth surfaces for easy cleaning.
3. Recessed hand grips are available for lifting and emptying.
4. Bottom hand-holds assist in emptying.



| Model | Description | Dimensions | Capacity | Color | Pack |
|-------|----------------------|----------------------|----------|-------|------|
| 1425 | Rigid Liner for 1305 | 32.5 × 18.9 × 32.4cm | 12L | BLA | 2 |
| 1426 | Rigid Liner for 1306 | 37.6 × 23.1 × 46.1cm | 26L | BLA | 2 |
| 1427 | Rigid Liner for 1307 | 40.2 × 24.9 × 64.6cm | 44L | BLA | 2 |
| 1428 | Rigid Liner for 1308 | 45.1 × 25.9 × 71.8cm | 58L | BLA | 2 |
| 1429 | Rigid Liner for 1309 | 51.6 × 30.0 × 74.3cm | 75L | BLA | 2 |

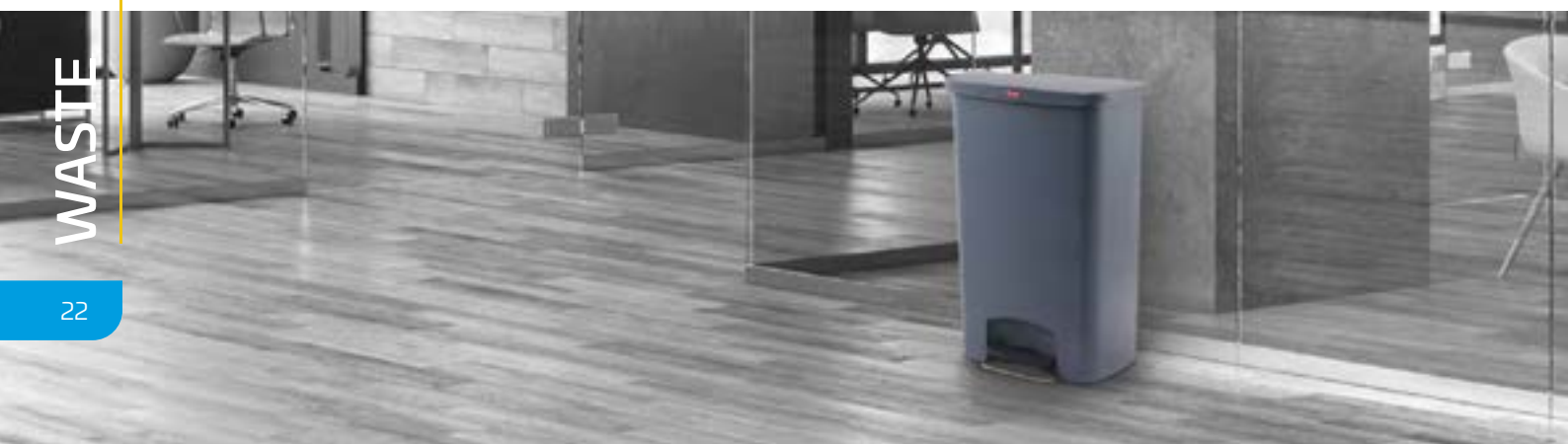

SVELTE® STEP-ON CONTAINERS WITH SIDE PEDAL



PRODUCT FEATURES:

1. Our products are made of high quality material and have a sturdy structure to prolong life.
2. Tough, puncture-resistant, all-plastic construction, resistant to damage or dents.
3. The slim rectangle shape is optimized to fit tight spaces.
4. Quiet, heavy-duty pedal for hands-free hygienic use.
5. Soft-close lid prevents noise effectively.
6. Hold liquid with standard rigid liner.



| Model | Description | Dimensions | Capacity | Color | Pack |
|-------|---------------------------|----------------------|----------|---|------|
| 1301 | SVELTE® Step-on Container | 27.0 × 49.2 × 56.0cm | 30L | BLUE, GRAY, WHT, YEL, GRN, RED, BLA, BEIG | 1 |
| 1302 | SVELTE® Step-on Container | 30.7 × 50.7 × 72.1cm | 50L | BLUE, GRAY, WHT, YEL, GRN, RED, BLA, BEIG | 1 |
| 1303 | SVELTE® Step-on Container | 34.7 × 54.4 × 78.2cm | 68L | BLUE, GRAY, WHT, YEL, GRN, RED, BLA, BEIG | 1 |
| 1304 | SVELTE® Step-on Container | 37.9 × 60.1 × 81.2cm | 90L | BLUE, GRAY, WHT, YEL, GRN, RED, BLA, BEIG | 1 |

RIGID LINERS FOR SVELTE® STEP-ON CONTAINERS WITH SIDE PEDAL

PRODUCT FEATURES:

1. Helps prolong the life of your containers.
2. Durable plastic construction with smooth surfaces for easy cleaning.
3. Recessed hand grips are available for lifting and emptying.
4. Bottom hand-holds assist in emptying.



| Model | Description | Dimensions | Capacity | Color | Pack |
|-------|----------------------|----------------------|----------|-------|------|
| 1421 | Rigid Liner for 1301 | 42.0 × 19.0 × 46.9cm | 30L | BLA | 2 |
| 1422 | Rigid Liner for 1302 | 45.1 × 24.3 × 64.0cm | 50L | BLA | 2 |
| 1423 | Rigid Liner for 1303 | 48.2 × 27.9 × 70.0cm | 68L | BLA | 2 |
| 1424 | Rigid Liner for 1304 | 54.0 × 31.2 × 72.0cm | 90L | BLA | 2 |



THOR® STEP-ON ROLLOUT CONTAINERS

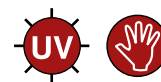

PRODUCT FEATURES:

1. Suitable for various commercial environments.
2. Hands-free operation improves work efficiency.
3. Heavy-duty 20cm wheels allow easy mobility, even over steps or curbstone.
4. Hinged lids close tightly and can be locked when fully lifted to prevent swinging during transport.
5. Non-protruding wheel position helps prevent damage to walls and doorways.
6. Ergonomic handle provides more flexible control.
7. Smooth surface for easy cleaning.
8. Reinforced rims add strength and durability.
9. Soft-close lid prevents noise effectively.
10. 1037 and 1038 are rotomolded, designed for holding large volume of refuse. Its one-piece structure offers extraordinary strength and durability.



1035



1037

| Model | Description | Dimensions | Capacity | Color | Pack |
|-------|---------------------------------|-----------------------|----------|--------------------------------|------|
| 1035 | THOR® Step-On Rollout Container | 52.0 × 66.3 × 94.0cm | 120L | BLUE, GRAY, YEL, GRN, RED, BLA | 1 |
| 1036 | THOR® Step-On Rollout Container | 62.1 × 72.8 × 100.5cm | 190L | BLUE, GRAY, YEL, GRN, RED, BLA | 1 |
| 1037 | THOR® Step-On Rollout Container | 64.5 × 76.0 × 115.0cm | 240L | BLUE, GRAY, YEL, GRN, RED, BLA | 1 |
| 1038 | THOR® Step-On Rollout Container | 72.7 × 94.9 × 117.0cm | 360L | BLUE, GRAY, YEL, GRN, RED, BLA | 1 |

THOR® STEP-ON ROLLOUT CONTAINERS WITH CASTERS

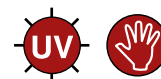

PRODUCT FEATURES:

1. Suitable for various commercial environments.
2. Hands-free operation improves work efficiency.
3. Heavy-duty 20cm wheels allow easy mobility, even over steps or curbstone.
4. Hinged lids close tightly and can be locked when fully lifted to prevent swinging during transport.
5. Ergonomic handle provides more flexible control.
6. Smooth surface for easy cleaning.
7. Reinforced rims add strength and durability.
8. Soft-close lid prevents noise effectively.
9. 1047 and 1048 are rotomolded, designed for holding large volume of refuse. Its one-piece structure offers extraordinary strength and durability.
10. Front swivel casters with brake enables enhanced maneuverability. Embedded casters are designed to avoid damage caused by collisions with walls and doorways.



1045



1047

| Model | Description | Dimensions | Capacity | Color | Pack |
|-------|--|-----------------------|----------|--------------------------------|------|
| 1045 | THOR® Step-On Rollout Container with Casters | 52.0 × 66.3 × 94.0cm | 120L | BLUE, GRAY, YEL, GRN, RED, BLA | 1 |
| 1046 | THOR® Step-On Rollout Container with Casters | 62.1 × 72.8 × 100.5cm | 190L | BLUE, GRAY, YEL, GRN, RED, BLA | 1 |
| 1047 | THOR® Step-On Rollout Container with Casters | 64.5 × 76.0 × 115.0cm | 240L | BLUE, GRAY, YEL, GRN, RED, BLA | 1 |
| 1048 | THOR® Step-On Rollout Container with Casters | 72.7 × 94.9 × 117.0cm | 360L | BLUE, GRAY, YEL, GRN, RED, BLA | 1 |

HANDS-FREE CONTAINERS



PRODUCT FEATURES:

1. Suitable for hotel lobbies, washing rooms, malls, restaurants, and snack outlets, etc.
2. Semi-round and square containers are available to meet a variety of demands.
3. Durable and crack resistant, compatible with outdoor conditions.
4. Space-efficient and elegant half-round shape suitable for tight spaces.
5. Hands-free, drop-and-swing lid design provides easy access for refuse disposal. Closes quickly to contain odors and prevent the entry of insects, such as house flies.
6. Multiple interchangeable tops are available to suit various applications.



| Model | Description | Dimensions | Capacity | Color | Pack |
|-------|----------------------|----------------------|----------|----------------------|------|
| 1223 | Half-round Container | 51.4 × 31.7 × 72.4cm | 80L | GRAY, BEIG | 4 |
| 1271 | Square Container | 39.4 × 39.4 × 78.5cm | 87L | GRAY, BRN, BLA, BEIG | 4 |
| 1281 | Square Container | 36.6 × 36.6 × 71.0cm | 75L | GRAY, BRN, BLA, BEIG | 4 |
| 1282 | Square Container | 49.5 × 49.5 × 70.2cm | 132L | GRAY, BEIG | 4 |
| 1283 | Square Container | 49.5 × 49.5 × 87.0cm | 190L | GRAY, BEIG | 4 |
| 1284 | Square Container | 41.2 × 41.2 × 72.4cm | 90L | GRAY | 4 |

TOPS

| | | | | | |
|------|-----------------------------------|----------------------|-----|-----------------|---|
| 1653 | Half-round Top for 1223 | 53.5 × 33.0 × 23.0cm | N/A | GRAY, BLA, BEIG | 4 |
| 1681 | Square Top for 1271 | 40.6 × 40.6 × 10.2cm | N/A | GRAY, BLA, BEIG | 4 |
| 1682 | Bottle/Tin Recycling Top for 1271 | 40.6 × 40.6 × 8.1cm | N/A | BLUE, GRN, RED | 4 |
| 1683 | Paper Recycling Top for 1271 | 40.6 × 40.6 × 8.1cm | N/A | BLUE, GRN | 4 |
| 1684 | Bottle/Tin Recycling Top for 1282 | 51.0 × 51.0 × 15.9cm | N/A | BLUE, GRN | 4 |
| 1685 | Paper Recycling Top for 1282 | 51.0 × 51.0 × 15.9cm | N/A | BLUE, GRN | 4 |



SOFT WASTEBASKETS



PRODUCT FEATURES:

1. Slim design, cost efficient, fits tight spaces.
2. Rolled rims add strength and are easy to clean.
3. Round trims on all openings protect containers and reduces potential for injury.
4. Fits under a standard desk to allow convenient desk-side waste management.
5. Round swing tops allow easy access without reducing wastebasket capacity.
6. Hands-free top contributes to high waste management efficiency.



Optional label kit (1851) for effective garbage sorting



1672

1241

1242

1243

1244

1245

| Model | Description | Dimensions | Capacity | Color | Pack |
|-------|---------------------------|----------------------|----------|----------------------------|------|
| 1241 | Paper Recycling Container | 26.9 × 18.5 × 29.7cm | 3L | BLUE, GRAY, GRN, BLA | 12 |
| 1242 | Wastebasket, Small | 28.9 × 21.0 × 30.8cm | 13L | GRAY, BLA, BEIG | 12 |
| 1243 | Wastebasket, Medium | 36.5 × 26.0 × 38.1cm | 26L | BLUE, GRAY, GRN, BLA, BEIG | 12 |
| 1244 | Wastebasket, Large | 38.7 × 27.9 × 50.5cm | 39L | BLUE, GRAY, GRN, BLA, BEIG | 12 |
| 1245 | Wastebasket, Large | 34.7 × 27.0 × 45.8cm | 30L | BLUE, GRAY, GRN, BLA, BEIG | 12 |

TOPS

| | | | | | |
|------|-------------------------|----------------------|-----|-----------------|---|
| 1672 | Hands-free Top for 1242 | 30.0 × 22.0 × 12.8cm | N/A | GRAY, BLA, BEIG | 6 |
| 1673 | Hands-free Top for 1243 | 38.1 × 27.6 × 15.2cm | N/A | GRAY, BLA, BEIG | 6 |
| 1674 | Hands-free Top for 1244 | 40.6 × 29.5 × 17.8cm | N/A | GRAY, BLA, BEIG | 6 |

UNFIRE® FIRE-RESISTANT WASTEBASKETS



PRODUCT FEATURES:

1. Fire-retardant materials add strength and prolong life.
2. Textured finish helps minimize appearance of surface scratches and is easy to clean.
3. Qualified with Underwriters Laboratories (UL) certification; fire within the bin is unable to melt the trash bin.
4. Choose from a variety of capacities and colors.



Fire-resistant



1261

1262

1263

1264

| Model | Description | Dimensions | Capacity | Color | Pack |
|-------|------------------------------------|----------------------|----------|-----------------|------|
| 1261 | UNFIRE® Fire-resistant Wastebasket | 22.6 × 16.2 × 27.4cm | 6.6L | BLA, BEIG | 6 |
| 1262 | UNFIRE® Fire-resistant Wastebasket | 28.3 × 21.0 × 31.1cm | 13L | GRAY, BLA, BEIG | 6 |
| 1263 | UNFIRE® Fire-resistant Wastebasket | 36.8 × 26.7 × 38.9cm | 26L | GRAY, BLA, BEIG | 6 |
| 1264 | UNFIRE® Fire-resistant Wastebasket | 38.1 × 28.6 × 50.8cm | 38L | BEIG | 4 |

STEEL MESH BINS

PRODUCT FEATURES:

1. Designed for desk-side application.
2. Designed to be free of rolled rim wire to prevent hooking clothes.
3. Coated with epoxy paint.
4. Sturdy base made of premium steel.



1291

1292

1293

| Model | Description | Dimensions | Capacity | Color | Pack |
|-------|-------------------------|----------------------|----------|------------|------|
| 1291 | Round Wastebasket | 29.2 × 36.0cm | 19L | BLA, MSILV | 6 |
| 1292 | Square Wastebasket | 27.0 × 27.0 × 35.0cm | 19L | MSILV | 3 |
| 1293 | Rectangular Wastebasket | 42.3 × 25.4 × 37.0cm | 28L | BLA | 3 |

STAINLESS STEEL TRASH CANS

PRODUCT FEATURES:

1. Made of heavy-duty fireproof material, extremely durable.
2. Concealed trash bag design provides a clean and tidy appearance.
3. Unique base design protects floors.
4. For indoor use.



2401

2402

2403

| Model | Description | Dimensions | Capacity | Color | Pack |
|-------|---------------------------|---------------|----------|-------|------|
| 2401 | Stainless Steel Trash Can | 23.0 × 27.0cm | 7L | MSILV | 1 |
| 2402 | Stainless Steel Trash Can | 23.5 × 27.0cm | 7L | MSILV | 1 |
| 2403 | Stainless Steel Trash Can | 20.5 × 30.0cm | 8L | MSILV | 1 |





Perfect Waste Sorting and Recycling Solutions

For collecting and sorting various types of waste, our large capacity bins can meet a multitude of needs across different workplaces.

Sturdy and Durable

Durable and crack-resistant, even under tough conditions both indoor and outdoor.

Sorting And Recycling Categories Are Easily Defined

Recycling lids and bins of different Colors can facilitate the recycling of recyclable paper, metal, bottles and other recyclable materials, making classification and recycling more convenient and efficient.



THOR® RECYCLING CONTAINERS

PRODUCT FEATURES:

1. Easy to maneuver.
2. Can serve as central collection containers or shipping containers, reducing the amount of handling.
3. Couple with dollies to transport recyclable waste with ease and efficiency.
4. Dollies are sold separately.
5. All containers come standard with "Recycle" symbols.



| Model | Description | Dimensions | Capacity | Color | Pack |
|-------|----------------------------------|----------------------|----------|-------|------|
| 1016 | THOR® Round Recycling Container | 49.0 × 57.0cm | 75L | BLUE | 6 |
| 1017 | THOR® Round Recycling Container | 56.0 × 70.0cm | 121L | BLUE | 6 |
| 1018 | THOR® Round Recycling Container | 61.0 × 80.0cm | 166L | BLUE | 4 |
| 1234 | THOR® Square Recycling Container | 59.7 × 59.7 × 73.0cm | 150L | BLUE | 4 |

THOR® TOPS

PRODUCT FEATURES:

1. Interchangeable, Color-coded tops promote waste separation.
2. Slotted top for paper.
3. Round-hole tops for glass bottles, glass jars, and metal cans.



| Model | Description | Dimensions | Capacity | Color | Pack |
|-------|---|---------------|----------|-----------|------|
| 1622 | THOR® Funnel Top for 1016 | 50.0 × 11.5cm | N/A | BLUE, GRN | 6 |
| 1623 | THOR® Funnel Top for 1017 | 56.8 × 12.9cm | N/A | BLUE, GRN | 4 |
| 1635 | THOR® Bottle and Can Recycling Top for 1017 | 57.2 × 10.0cm | N/A | BLUE, GRN | 6 |
| 1636 | THOR® Paper Recycling Top for 1017 | 57.2 × 10.0cm | N/A | BLUE, GRN | 6 |
| 1637 | THOR® Single Stream Recycling Top for 1017 | 57.2 × 10.0cm | N/A | BLUE, GRN | 6 |

THOR® DOLLIES

PRODUCT FEATURES:

1. Easy mobility and maneuverability of heavy loads.
2. Swivel casters offer easy mobility.
3. Attach trash containers with ease.
4. Sturdy structural foam construction won't rust, dent, chip, or peel.



Foot fixing position,
easy loading and unloading



| Model | Description | Dimensions | Capacity | Color | Pack |
|-------|--|-----------------------|----------|-------|------|
| 1811 | THOR® Dolly for 1010/1012/1013/1014/1015 | 46.4 × 16.8cm | N/A | BLA | 2 |
| 1812 | THOR® Square Dolly for 1231/1233 | 43.8 × 15.9cm | N/A | BLA | 2 |
| 1813 | THOR® Quiet Dolly for 1010/ 1012/1013/1014/1015 | 46.4 × 16.8cm | N/A | BLA | 2 |
| 1818 | THOR® Drum Dolly for 1010/1012/ 1013/1014/1015/1231/1233 | 114.3 × 51.4 × 20.3cm | N/A | BLA | 1 |

SVELTE® RECYCLING CONTAINERS



PRODUCT FEATURES:

1. Station containers serve as a convenient central collection site for multiple work stations.
2. All containers come standard with a "Recycle" symbol.
3. Optional dolly for 1212, 1214 and 1221. Refer to Page 20.



| Model | Description | Dimensions | Capacity | Color | Pack |
|-------|--------------------------------|----------------------|----------|-----------|------|
| 1212 | SVELTE® Recycling Container | 57.0 × 27.2 × 63.2cm | 60L | BLUE, GRN | 4 |
| 1214 | SVELTE® Recycling Container | 57.0 × 27.2 × 75.6cm | 87L | BLUE, GRN | 4 |
| 1217 | SVELTE® Recycling Container | 49.9 × 24.9 × 63.0cm | 46L | BLUE, GRN | 4 |
| 1221 | SVELTE® Recycling Container | 51.3 × 27.2 × 75.6cm | 87L | BLUE, GRN | 4 |
| 1224 | Half-round Recycling Container | 51.4 × 31.7 × 72.4cm | 80L | BLUE | 4 |

SVELTE® TOPS



PRODUCT FEATURES:

1. Interchangeable, Color-coded tops promote waste separation.
2. Slotted blue top for paper.
3. Green and blue round-hole tops for glass bottles, glass jars, and metal cans.
4. Gray handle top for general refuse.
5. 1218 collodion structure molding, sturdy and durable, with convenient and efficient fixed slots for garbage bags.

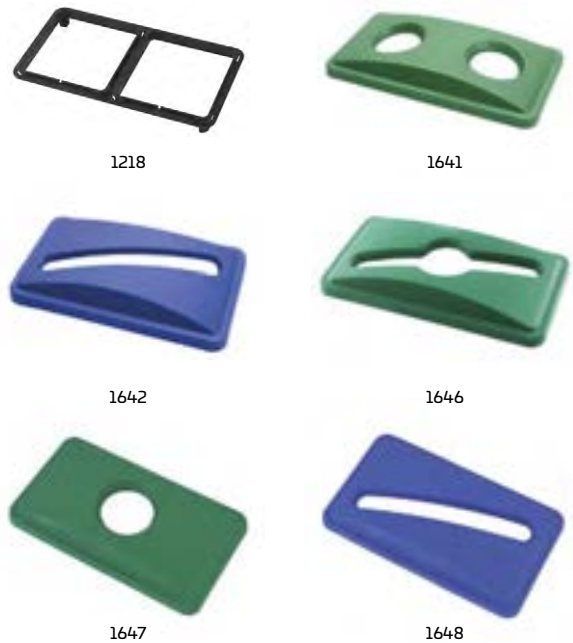

1641 can be used with the Classification collection lids (1219) to facilitate garbage classification management

Fixed slots for garbage bags on 1218 help with waste separation

| Model | Description | Dimensions | Capacity | Color | Pack |
|-------|--|---------------------|----------|-------------------------------------|------|
| 1218 | Garbage Classification Fixing Device for 1212/1214 | 50.7 × 27.2 × 5.0cm | N/A | BLA | 1 |
| 1219 | Classification Collection Lid for 1641 | 18.0 × 3.2cm | N/A | BLUE, YEL, GRN, RED | 4 |
| 1641 | SVELTE® Bottle and Can Recycling Top | 52.3 × 28.8 × 6.7cm | N/A | BLUE, GRAY, YEL, GRN, RED, BLA, BRN | 4 |
| 1642 | SVELTE® Paper Recycling Top | 52.3 × 28.8 × 6.7cm | N/A | BLUE, GRN, RED | 4 |
| 1646 | SVELTE® Single Stream Recycling Top | 52.3 × 28.8 × 6.7cm | N/A | GRN | 4 |
| 1647 | SVELTE® Bottle and Can Recycling Top for 1217 | 45.2 × 25.8 × 6.2cm | N/A | BLUE, GRN | 4 |
| 1648 | SVELTE® Paper Recycling Top for 1217 | 45.2 × 25.8 × 6.2cm | N/A | BLUE | 4 |

SVELTE® WASTE SORTING SYSTEM



PRODUCT FEATURES:

1. Comprehensive recycling solutions.
2. Fixed recycling container serves as waste recycling center for multiple workspaces.
3. Lids with different structures and Colors are available for easy waste sorting.
4. Capacities can accommodate larger sized recycling material.
5. Waste category labels are available for effective waste sorting.
6. Multiple combinations offer more effective waste sorting management.



| Model | Description | Dimensions | Capacity | Color | Pack |
|-------|-------------------|----------------------|----------|-------|------|
| 1211 | SVELTE® Container | 57.0 × 27.2 × 63.2cm | 60L | LGARY | 4 |
| 1213 | SVELTE® Container | 57.0 × 27.2 × 75.6cm | 87L | LGARY | 4 |
| 1220 | SVELTE® Container | 51.3 × 27.2 × 75.6cm | 87L | LGARY | 4 |

TOPS

| Model | Description | Dimensions | Capacity | Color | Pack |
|-------|---------------------------------------|----------------------|----------|-------------------------------------|------|
| 1700 | Lid for 1211/1213 | 52.0 × 28.2 × 11.8cm | N/A | LGARY | 4 |
| 1701 | Paper Recycling Top for 1700 | 41.5 × 22.6 × 1.6cm | N/A | BLUE, GRAY, YEL, GRN, RED, BLA, BRN | 4 |
| 1702 | Bottle and Can Recycling Top for 1700 | 41.5 × 22.6 × 1.6cm | N/A | BLUE, GRAY, YEL, GRN, RED, BLA, BRN | 4 |
| 1703 | Paper/Bottle Recycling Top for 1700 | 41.5 × 22.6 × 1.6cm | N/A | BLUE, GRAY, YEL, GRN, RED, BLA, BRN | 4 |
| 1704 | Enclosed Lid for 1700 | 41.5 × 22.6 × 1.6cm | N/A | BLUE, GRAY, YEL, GRN, RED, BLA, BRN | 4 |

WASTE SORTING LOGO

| Model | Description | Dimensions | Capacity | Color | Pack |
|-------|-------------------------|---------------|----------|-------|------|
| 1842 | Label Kit for 1700 | 39.0 × 7.0cm | N/A | N/A | 1 |
| 1843 | Label Kit for 1211/1213 | 16.8 × 29.7cm | N/A | N/A | 1 |

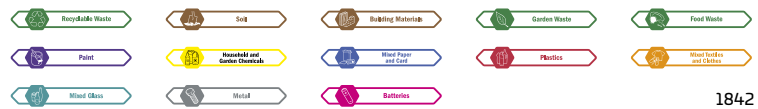
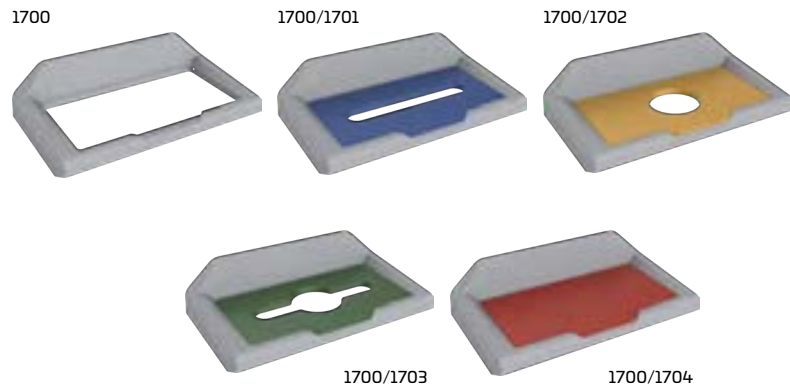

1842

1843

SVELTE® WASTE SORTING SYSTEM



PRODUCT FEATURES:

1. Comprehensive recycling solutions.
2. Fixed recycling container serves as waste recycling center for multiple workspaces.
3. Lids with different structures and Colors are available for easy waste sorting.
4. Capacities can accommodate larger sized recycling material.
5. Waste category labels are available for effective waste sorting.
6. Multiple combinations offer more effective waste sorting management.



1211

1213

1220

| Model | Description | Dimensions | Capacity | Color | Pack |
|-------|-------------------|----------------------|----------|-------|------|
| 1211 | SVELTE® Container | 57.0 × 27.2 × 63.2cm | 60L | LGARY | 4 |
| 1213 | SVELTE® Container | 57.0 × 27.2 × 75.6cm | 87L | LGARY | 4 |
| 1220 | SVELTE® Container | 51.3 × 27.2 × 75.6cm | 87L | LGARY | 4 |

TOPS

| Model | Description | Dimensions | Capacity | Color | Pack |
|-------|---------------------------------------|----------------------|----------|-------------------------------------|------|
| 1710 | Lid for 1211/1213 | 28.2 × 52.0 × 14.3cm | N/A | LGARY | 4 |
| 1711 | Paper Recycling Top for 1710 | 21.6 × 46.6 × 2.0cm | N/A | BLUE, GRAY, YEL, GRN, RED, BLA, BRN | 4 |
| 1712 | Bottle and Can Recycling Top for 1710 | 21.6 × 46.6 × 2.0cm | N/A | BLUE, GRAY, YEL, GRN, RED, BLA, BRN | 4 |
| 1713 | Paper/Bottle Recycling Top for 1710 | 21.6 × 46.6 × 2.0cm | N/A | BLUE, GRAY, YEL, GRN, RED, BLA, BRN | 4 |
| 1714 | Enclosed Lid for 1710 | 21.6 × 46.6 × 2.0cm | N/A | BLUE, GRAY, YEL, GRN, RED, BLA, BRN | 4 |

WASTE SORTING LOGO

| Model | Description | Dimensions | Capacity | Color | Pack |
|-------|-------------------------|---------------|----------|-------|------|
| 1844 | Label Kit for 1710 | 19.9 × 8.5cm | N/A | N/A | 1 |
| 1845 | Label Kit for 1211/1213 | 13.0 × 23.0cm | N/A | N/A | 1 |



2 Stream

3 Stream

4 Stream

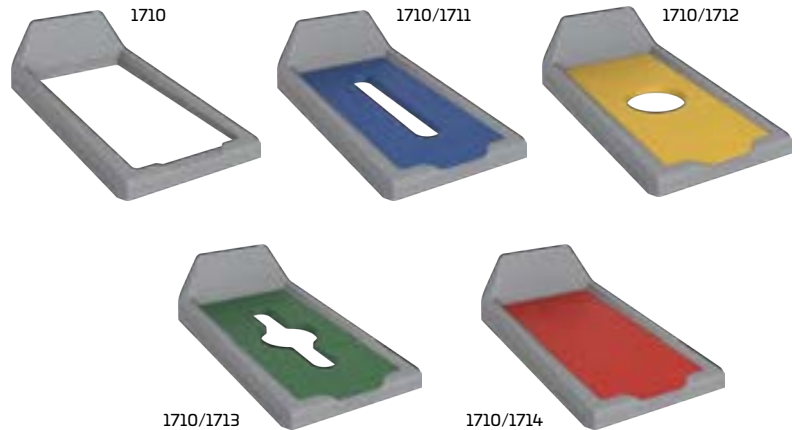

1844



1845

SVELTE® WASTE SORTING SYSTEM



PRODUCT FEATURES:

1. Comprehensive recycling solutions.
2. Fixed recycling container serves as waste recycling center for multiple workspaces.
3. Lids with different structures and Colors are available for easy waste sorting.
4. Capacities can accommodate larger sized recycling material.
5. Waste category labels are available for effective waste sorting.
6. Multiple combinations offer more effective waste sorting management.



1215

| Model | Description | Dimensions | Capacity | Color | Pack |
|-------|-------------------|----------------------|----------|-------|------|
| 1215 | SVELTE® Container | 49.9 × 24.9 × 63.0cm | 46L | LGARY | 4 |

TOPS

| | | | | | |
|------|---------------------------------------|----------------------|-----|-------------------------------------|---|
| 1730 | Lid for 1215 | 45.7 × 26.0 × 11.8cm | N/A | LGARY | 4 |
| 1731 | Paper Recycling Top for 1730 | 35.2 × 20.4 × 1.6cm | N/A | BLUE, GRAY, YEL, GRN, RED, BLA, BRN | 4 |
| 1732 | Bottle and Can Recycling Top for 1730 | 35.2 × 20.4 × 1.6cm | N/A | BLUE, GRAY, YEL, GRN, RED, BLA, BRN | 4 |
| 1733 | Paper/Bottle Recycling Top for 1730 | 35.2 × 20.4 × 1.6cm | N/A | BLUE, GRAY, YEL, GRN, RED, BLA, BRN | 4 |
| 1734 | Enclosed Lid for 1730 | 35.2 × 20.4 × 1.6cm | N/A | BLUE, GRAY, YEL, GRN, RED, BLA, BRN | 4 |

WASTE SORTING LOGO

| | | | | | |
|------|--------------------|---------------|-----|-----|---|
| 1847 | Label Kit for 1730 | 36.2 × 8.0cm | N/A | N/A | 1 |
| 1843 | Label Kit for 1215 | 16.8 × 29.7cm | N/A | N/A | 1 |



2 Stream



3 Stream



4 Stream

1730



1730/1731



1730/1732

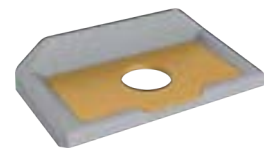

1730/1733

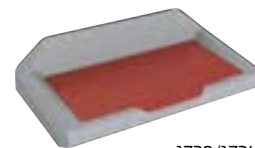

1730/1734



1847



1843

SVELTE® WASTE SORTING SYSTEM



PRODUCT FEATURES:

1. Comprehensive recycling solutions.
2. Fixed recycling container serves as waste recycling center for multiple workspaces.
3. Lids with different structures and Colors are available for easy waste sorting.
4. Capacities can accommodate larger sized recycling material.
5. Waste category labels are available for effective waste sorting.
6. Multiple combinations offer more effective waste sorting management.



1215

| Model | Description | Dimensions | Capacity | Color | Pack |
|---------------------------|---------------------------------------|----------------------|----------|-------------------------------------|------|
| 1215 | SVELTE® Container | 49.9 × 24.9 × 63.0cm | 46L | LGARY | 4 |
| TOPS | | | | | |
| 1740 | Lid for 1215 | 26.0 × 45.7 × 14.3cm | N/A | LGARY | 4 |
| 1741 | Paper Recycling Top for 1740 | 19.4 × 40.3 × 2.0cm | N/A | BLUE, GRAY, YEL, GRN, RED, BLA, BRN | 4 |
| 1742 | Bottle and Can Recycling Top for 1740 | 19.4 × 40.3 × 2.0cm | N/A | BLUE, GRAY, YEL, GRN, RED, BLA, BRN | 4 |
| 1743 | Paper/Bottle Recycling Top for 1740 | 19.4 × 40.3 × 2.0cm | N/A | BLUE, GRAY, YEL, GRN, RED, BLA, BRN | 4 |
| 1744 | Enclosed Lid for 1740 | 19.4 × 40.3 × 2.0cm | N/A | BLUE, GRAY, YEL, GRN, RED, BLA, BRN | 4 |
| WASTE SORTING LOGO | | | | | |
| 1848 | Label Kit for 1740 | 17.7 × 8.0cm | N/A | N/A | 1 |
| 1849 | Label Kit for 1215 | 9.5 × 16.8cm | N/A | N/A | 1 |



2 Stream

3 Stream

4 Stream

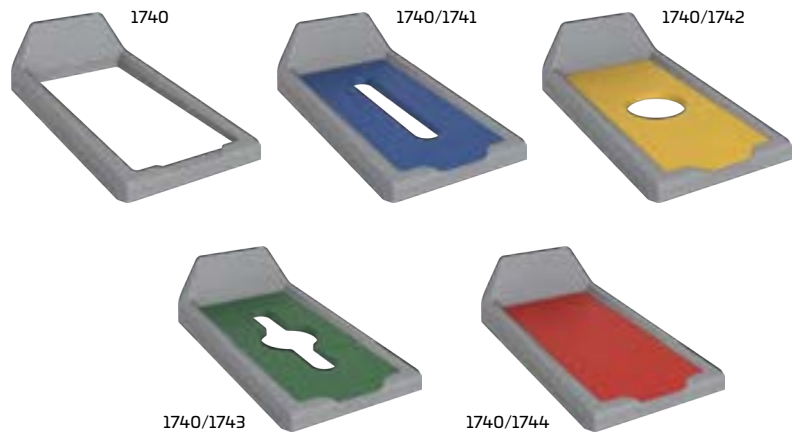

1848



1849

WASTE SORTING SYSTEM



PRODUCT FEATURES:

1. Comprehensive recycling solutions.
2. Fixed recycling container serves as waste recycling center for multiple workspaces.
3. Lids with different structures and Colors are available for easy waste sorting.
4. Waste category labels are available for effective waste sorting.
5. Multiple combinations offer more effective waste sorting management.



1271

| Model | Description | Dimensions | Capacity | Color | Pack |
|-------|------------------|----------------------|----------|-------|------|
| 1271 | Square Container | 39.4 x 39.4 x 78.5cm | 87L | LGARY | 4 |

TOPS

| | | | | | |
|------|---------------------------------------|----------------------|-----|-------------------------------------|---|
| 1720 | Top for 1271 | 40.2 x 40.2 x 12.8cm | N/A | LGARY | 4 |
| 1721 | Paper Recycling Top for 1720 | 31.8 x 32.5 x 2.1cm | N/A | BLUE, GRAY, YEL, GRN, RED, BLA, BRN | 4 |
| 1722 | Bottle and Can Recycling Top for 1720 | 31.8 x 32.5 x 2.1cm | N/A | BLUE, GRAY, YEL, GRN, RED, BLA, BRN | 4 |
| 1723 | Paper/Bottle Recycling Top for 1720 | 31.8 x 32.5 x 2.1cm | N/A | BLUE, GRAY, YEL, GRN, RED, BLA, BRN | 4 |
| 1724 | Large Waste Recycling Top for 1720 | 31.8 x 32.5 x 2.1cm | N/A | BLUE, GRAY, YEL, GRN, RED, BLA, BRN | 4 |
| 1725 | Enclosed Lid for 1720 | 31.8 x 34.3 x 2.1cm | N/A | BLUE, GRAY, YEL, GRN, RED, BLA, BRN | 4 |

WASTE SORTING LOGO

| | | | | | |
|------|--------------------|---------------|-----|-----|---|
| 1846 | Label Kit for 1720 | 28.4 x 7.0cm | N/A | N/A | 1 |
| 1843 | Label Kit for 1271 | 16.8 x 29.7cm | N/A | N/A | 1 |



1720/1721

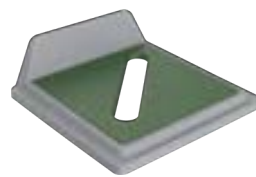

1720/1722

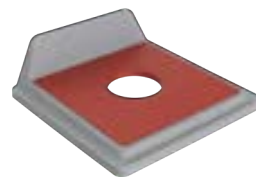

1720/1723

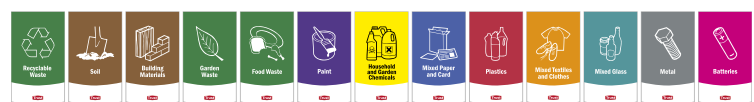
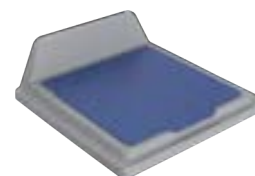
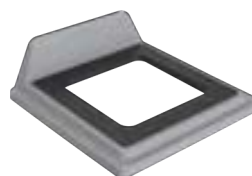
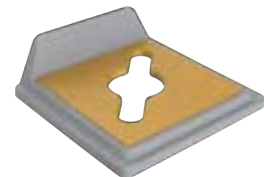

THOR® WASTE SORTING SYSTEM



PRODUCT FEATURES:

1. Comprehensive recycling solutions.
2. Fixed recycling container serves as waste recycling center for multiple workspaces.
3. Lids with different structures and Colors are available for easy waste sorting.
4. Waste category labels are available for effective waste sorting.
5. Multiple combinations offer more effective waste sorting management.



1013

| Model | Description | Dimensions | Capacity | Color | Pack |
|--------------------|---------------------------------------|----------------------|----------|-------------------------------------|------|
| 1013 | THOR® Round Container | 56.0 × 70.0cm | 121L | LGARY | 6 |
| TOPS | | | | | |
| 1750 | Round Bins Lid for 1013 | 61.3 × 57.3 × 13.9cm | N/A | LGARY | 6 |
| 1751 | Paper Recycling Top for 1750 | 39.8 × 34.5 × 2.2cm | N/A | BLUE, GRAY, YEL, GRN, RED, BLA, BRN | 6 |
| 1752 | Bottle and Can Recycling Top for 1750 | 39.8 × 34.5 × 2.2cm | N/A | BLUE, GRAY, YEL, GRN, RED, BLA, BRN | 6 |
| 1753 | Paper/Bottle Recycling Top for 1750 | 39.8 × 34.5 × 2.2cm | N/A | BLUE, GRAY, YEL, GRN, RED, BLA, BRN | 6 |
| 1754 | Large Waste Recycling Top for 1750 | 39.8 × 34.5 × 2.2cm | N/A | BLUE, GRAY, YEL, GRN, RED, BLA, BRN | 6 |
| 1755 | Enclosed Lid for 1750 | 39.8 × 33.6 × 3.0cm | N/A | BLUE, GRAY, YEL, GRN, RED, BLA, BRN | 6 |
| WASTE SORTING LOGO | | | | | |
| 1839 | Label Kit for 1750 | 21.7 × 7.5cm | N/A | N/A | 1 |
| 1843 | Label Kit for 1013 | 16.8 × 29.7cm | N/A | N/A | 1 |



2 Stream



3 Stream



4 Stream

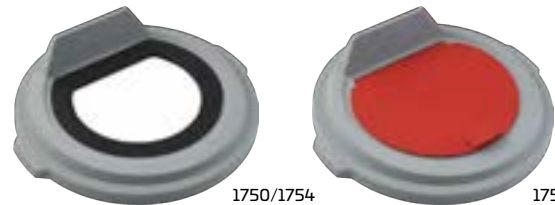

1839



1843

ROLLOUT RECYCLING BINS, LARGE-CAPACITY



PRODUCT FEATURES:

1. Can serve as central collection containers or shipping containers, reducing the amount of handling.
2. Rotomolded, industrial-grade, easy handling.
3. Smooth surfaces are easy to clean and resist corrosion.
4. The metal frame on 4724 and 4725 provides durable support.
5. 4523 angle design of front end assists with emptying.



| Model | Description | Dimensions | Capacity | Color | Pack |
|-------|-------------------------------|------------------------|----------|-------|------|
| 4523 | Tilt Truck, Standard Duty | 183.2 × 85.1 × 111.4cm | 800L | BLUE | 1 |
| 4724 | 0.4 m ³ Cube Truck | 117.0 × 84.0 × 86.0cm | 400L | BLUE | 2 |
| 4725 | 0.5 m ³ Cube Truck | 125.5 × 92.0 × 94.0cm | 500L | BLUE | 2 |

ROLLOUT RECYCLING CONTAINERS



PRODUCT FEATURES:

1. Practical and efficient, designed for large amounts of trash.
2. Heavy-duty 20cm wheels afford easy mobility, even over steps or curbing.
3. Attached hinged lid fits securely; swings back and locks.
4. Molded-in axle retainer adds strength.
5. 1026 is rotomolded designed for large amounts of trash. Its one-piece structure offers extraordinary strength and durability.



| Model | Description | Dimensions | Capacity | Color | Pack |
|-------|--|-----------------------|----------|-------|------|
| 1022 | THOR® Rollout Recycling Trash Bin with Cover | 72.4 × 59.4 × 92.7cm | 190L | BLUE | 2 |
| 1026 | THOR® Rollout Recycling Bin, Rotomolded | 69.7 × 93.4 × 121.4cm | 360L | BLUE | 1 |



RISTON® OUTDOOR RECYCLING CONTAINERS



PRODUCT FEATURES:

1. Large-capacity recycling container for any outdoor environment.
2. Attractive with a side-door design.
3. Durable molded construction with smooth surfaces, easy to clean.
4. Fixed device adds stability and safety for outdoor use.
5. Can be fixed to the ground with screws.
6. Built-in garbage bag holder, conveniently holds the garbage bag in place.
7. Optional hard inner bins, suitable for storing sharp and heavy waste.



2104



2105

| Model | Description | Dimensions | Capacity | Color | Pack |
|-------|------------------------------------|-----------------------|----------|-----------|------|
| 2104 | RISTON® Paper Recycling Container | 62.9 × 64.0 × 107.0cm | 190L | BLUE, GRN | 1 |
| 2105 | RISTON® Bottle Recycling Container | 62.9 × 64.0 × 107.0cm | 190L | BLUE, GRN | 1 |
| 1282 | Rigid Liner | 49.5 × 49.5 × 70.2cm | 132L | GRAY | 4 |

DEKSID RECYCLING CONTAINERS



PRODUCT FEATURES:

1. An easy and effective way to recycle paper.
2. Designed to be used in systems with existing office containers and accessories.
3. Placed beside traditional wastebaskets to help recycle waste paper.



1246



1247



1249



1248



1241 can be used with optional label kit (1851) for effective garbage sorting management

| Model | Description | Dimensions | Capacity | Color | Pack |
|-------|--------------------------------------|----------------------|----------|----------------------|------|
| 1241 | Side Bin Recycling Center | 26.9 × 18.5 × 29.7cm | 3L | BLUE, GRAY, GRN, BLA | 12 |
| 1246 | Deskside Recycling Container, Small | 28.9 × 21.0 × 30.8cm | 13L | BLUE, GRN | 12 |
| 1247 | Deskside Recycling Container, Medium | 36.5 × 26.0 × 38.1cm | 26L | BLUE, GRN | 12 |
| 1248 | Deskside Recycling Container, Large | 38.7 × 27.9 × 50.5cm | 39L | BLUE | 12 |
| 1249 | Deskside Recycling Container, Large | 34.7 × 27.0 × 45.8cm | 30L | BLUE | 12 |
| 1851 | Label Kit for 1241 | 14.3 × 2.2cm | N/A | N/A | 1 |



MEDICAL WASTE MANAGEMENT

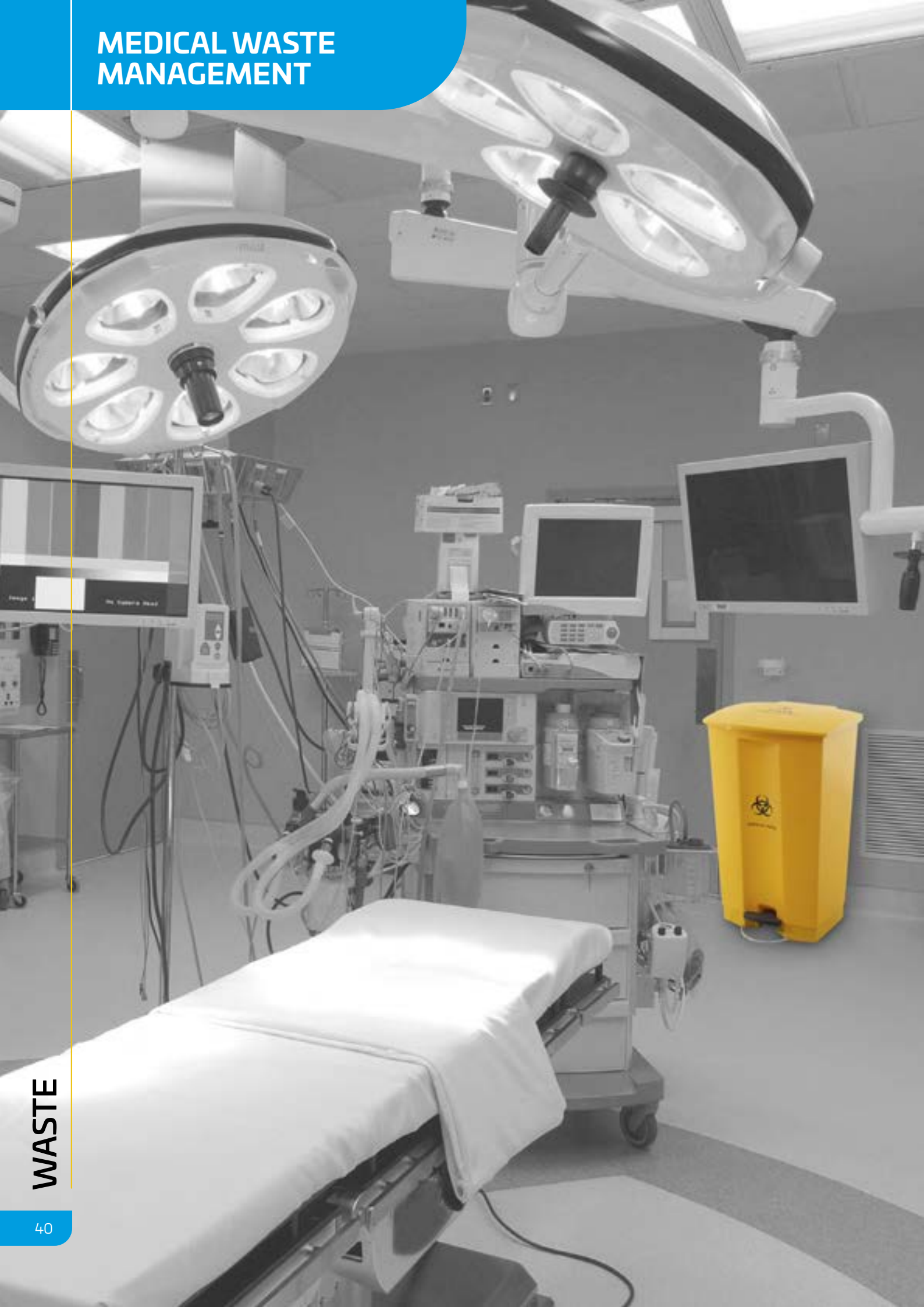

THOR® MEDICAL CONTAINERS

PRODUCT FEATURES:

1. Suitable for hospitals, clinics and other medical waste recycling applications.
2. Tough and durable all-plastic construction, reusable and puncture-resistant.
3. Seamless body ensures it is leakage-proof.
4. Smooth surfaces allow for easy cleaning and sterilizing.
5. Non-slip top allows for easy stacking.
6. Easy-grip handles assist with easy moving.
7. Hot stamped logos on yellow radiation-proof body are durable and non-fading.



1020



3013/3014

| Model | Description | Dimensions | Capacity | Color | Pack |
|-------|----------------------------|----------------------|----------|-------|------|
| 1019 | Round Case, with a Top | 49.0 × 57.0cm | 75L | YEL | 6 |
| 1020 | Round Case, with a Top | 56.0 × 70.0cm | 121L | YEL | 6 |
| 1235 | Square Case, with a Top | 54.6 × 54.6 × 57.8cm | 106L | YEL | 6 |
| 1236 | Square Case, with a Top | 59.7 × 59.7 × 73.3cm | 150L | YEL | 4 |
| 3013 | Medical Waste Recycle Case | 70.8 × 43.4 × 27.2cm | 53L | YEL | 6 |
| 3014 | Medical Waste Recycle Case | 70.8 × 43.4 × 38.4cm | 75L | YEL | 6 |

MEDICAL STEP-ON CONTAINERS



PRODUCT FEATURES:

1. Suitable for hospital wards, etc.
2. Smooth surfaces assist easy cleaning and sterilizing.
3. Equipped with a tightly fitted lid to contain odors and prevent the entry of insects, such as house flies.
4. Tough, puncture-resistant, all-plastic construction, resistant to damage or dents.
5. Quiet, heavy-duty pedal for hands-free hygienic use.
6. Soft-close lid prevents noise effectively.
7. Optional leak-proof rigid liners are available to contain liquid. Refer to Page 21.
8. Hot stamped logos on yellow radiation-proof body are durable and non-fading.



1256



1257



1258



1259

| Model | Description | Dimensions | Capacity | Color | Pack |
|-------|---------------------------|----------------------|----------|-------|------|
| 1250 | Step-on Container | 33.7 × 32.4 × 40.2cm | 17L | YEL | 1 |
| 1256 | Step-on Container | 41.3 × 40.0 × 43.5cm | 30L | YEL | 1 |
| 1257 | Step-on Container | 41.3 × 40.0 × 60.0cm | 45L | YEL | 1 |
| 1258 | Step-on Container | 50.2 × 41.0 × 67.3cm | 68L | YEL | 1 |
| 1259 | Rollout Step-on Container | 50.2 × 44.7 × 82.6cm | 87L | YEL | 1 |

DECORATIVE WASTE CONTAINERS



Multiple Solutions

Our range includes products of various sizes, colors and materials and offers practical waste solutions for any area of the workplace.

Sustainable Development

Good product design, sound recyclability and durability, and use of environmentally friendly materials define our efforts towards environmental sustainability.

Smarter Decorative Receptacles

We provide customers with comprehensive, high efficiency and cost-effective waste solutions. Trust decorative receptacles offer a modern design, high quality surface treatment and long lasting performance both indoors and outdoors.



ROCKFACE® CONTAINERS WITH ASHTRAY TOP

PRODUCT FEATURES:

1. Suitable for the entrance to a building, hall or shopping center.
2. Comes with a wide opening for easy disposal of refuse.
3. The ashtray is a metal sand plate.
4. Optional faceplate available - sold separately.

ROCKFACE® CONTAINERS WITH DRUM-TYPE TOP

PRODUCT FEATURES:

1. Fit for applications in catering centers, theater halls or shopping centers.
2. Funnel-opening assists easy insertion of waste.
3. The hinged top can be tied up with a belt for easy access to contents.
4. Optional faceplate available - sold separately.

ROCKFACE® CONTAINERS WITH FUNNEL-TOP

PRODUCT FEATURES:

1. Fit for applications in catering centers, theater halls or shopping centers.
2. Funnel-opening assists easy insertion of waste.
3. The hinged top can be tied up with a belt for easy access to contents.
4. Optional faceplate available - sold separately.

ROCKFACE® FACEPLATES

PRODUCT FEATURES:

1. Clean and shiny faceplate for display of information and advertisement.
2. The dent-resistant faceplate supported by ABS is durable, resistant to tough weather conditions.



| Model | Description | Dimensions | Capacity | Color | Pack |
|-------|---|-----------------------|----------|----------------|------|
| 2011 | ROCKFACE® Container with an Ashtray Top, and 1281Liner | 53.5 × 53.5 × 77.5cm | 75L | BRN, LBRN | 1 |
| 2012 | ROCKFACE® Container with a Funnel-top, and 1281Liner | 53.5 × 53.5 × 77.5cm | 75L | BRN, LBRN | 1 |
| 2021 | ROCKFACE® Container with an Ashtray Top, and 1282Liner | 66.0 × 66.0 × 77.5cm | 132L | BRN, LBRN, BLA | 1 |
| 2022 | ROCKFACE® Container with a Funnel-top, and 1282Liner | 66.0 × 66.0 × 77.5cm | 132L | BRN, LBRN, BLA | 1 |
| 2023 | ROCKFACE® Container with a Drum-type Top, and 1282Liner | 66.0 × 66.0 × 101.6cm | 132L | BRN, LBRN, BLA | 1 |
| 2024 | ROCKFACE® Container with a Drum-type Ashtray Top, and 1282Liner | 66.0 × 66.0 × 101.6cm | 132L | BRN, LBRN, BLA | 1 |
| 2031 | ROCKFACE® Container with a Drum-type Top, and 1283Liner | 66.0 × 66.0 × 118.0cm | 190L | BRN, LBRN, BLA | 1 |
| 2032 | ROCKFACE® Container with a Drum-type Ashtray Top, and 1283Liner | 66.0 × 66.0 × 118.0cm | 190L | BRN, LBRN, BLA | 1 |

FACEPLATES

| | | | | | |
|------|--|---------------------|-----|--------------------|---|
| 2041 | ROCKFACE® Concrete Faceplate, for 2011, 2012 | 71.0 × 40.0 × 1.0cm | N/A | CORL, ROCK | 4 |
| 2042 | ROCKFACE® Concrete Faceplate, for 2021, 2022, 2023, 2024 | 71.0 × 52.6 × 1.0cm | N/A | CORL, ROCK, BSTONE | 4 |
| 2043 | ROCKFACE® Concrete Faceplate, for 2031, 2032 | 87.0 × 52.6 × 1.0cm | N/A | CORL, ROCK, BSTONE | 4 |
| 2044 | ROCKFACE® Ad Backing Faceplate, for 2031, 2032 | 87.0 × 52.6 × 1.0cm | N/A | CLR | 4 |

ORDERING PROCEDURE

Step 1: Select the container size and model

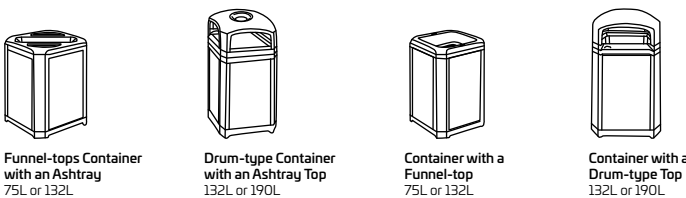

Step 2: Select decorative faceplates (four plates for each container)



ROCKFACE® DECORATIVE CONTAINERS

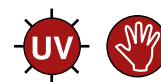

PRODUCT FEATURES:

1. Ideal for the use in building entrances, lobbies and shopping malls.
2. Made of heavy-duty, hot-dip galvanized fireproof steel.
3. Weather-resistant top withstands harsh weather.
4. The top has openings on four sides for easy disposal of refuse.
5. An ashtray is attached.
6. Levelers facilitate use on uneven surfaces.
7. Includes a leak proof inner container made from galvanized steel.
8. User assembly is not required.



Convenient **hinged top** allows easy access to remove barrel



Ashtray receptacle isolates cigarette butts and prevents the chance of fire

| Model | Description | Dimensions | Capacity | Color | Pack |
|-------|--|----------------|----------|-----------------|------|
| 2051 | Container with a Drum-type Ashtray Top | 25.4 × 62.5cm | 12L | GRAY, BRN, EGRN | 1 |
| 2052 | Container with a Drum-type Top | 25.4 × 61.0cm | 12L | GRAY, BRN, EGRN | 1 |
| 2061 | Container with a Drum-type Ashtray Top | 34.3 × 82.8cm | 45.4L | GRAY, BRN, EGRN | 1 |
| 2062 | Container with a Drum-type Top | 34.3 × 81.3cm | 45.4L | GRAY, BRN, EGRN | 1 |
| 2071 | Container with a Drum-type Ashtray Top, Rod Openings | 45.7 × 82.8cm | 90.8L | GRAY, BRN, EGRN | 1 |
| 2072 | Container with a Drum-type Top, Rod Openings | 45.7 × 81.3cm | 90.8L | GRAY, BRN, EGRN | 1 |
| 2081 | Container with a Drum-type Ashtray Top | 53.3 × 103.1cm | 109.8L | GRAY, BRN, EGRN | 1 |
| 2082 | Container with a Drum-type Top | 53.3 × 101.6cm | 109.8L | GRAY, BRN, EGRN | 1 |
| 2083 | Container with a Flat-type Top | 53.3 × 97.0cm | 109.8L | GRAY, BRN, EGRN | 1 |
| 2091 | Container with a Drum-type Top | 66.0 × 101.6cm | 181.7L | GRAY, BRN, EGRN | 1 |
| 2092 | Container with a Drum-type Top with Side Door | 66.0 × 101.6cm | 181.7L | GRAY, BRN, EGRN | 1 |
| 2093 | Container with a Flat-type Top | 66.0 × 97.0cm | 181.7L | GRAY, BRN, EGRN | 1 |



2091



2082



2061



2071



2072



2051



2052

STEELEDGE® CONTAINERS



PRODUCT FEATURES:

1. Ideal for use in hotels, airports, and train stations.
2. Ageless design, precisely manufactured - the perfect collection of sizes and shapes providing a fundamental solution.
3. Made of heavy-duty fireproof material, extreme durability.
4. Rubber rim effectively reduces damage to the product.
5. Unique base design protects floors.
6. Indoor use recommended.
7. Auto closing top and recessed handle facilitate moving and dumping.
8. Included a leak proof inner container made from galvanized steel.



| Model | Description | Dimensions | Capacity | Color | Pack |
|-------|--|---------------|----------|-------|------|
| 2310 | Ashtray/Trash, Mirror Chrome | 25.4 × 68.6cm | 13.2L | SS | 1 |
| 2311 | Ashtray/Trash, Satin Stainless Steel | 25.4 × 68.6cm | 13.2L | SSS | 1 |
| 2312 | Ashtray/Trash, Titanium Surface | 25.4 × 68.6cm | 13.2L | TITA | 1 |
| 2320 | Container Open-top, Mirror Chrome | 38.1 × 71.1cm | 56.8L | SS | 1 |
| 2321 | Container Open-top, Satin Stainless Steel | 38.1 × 71.1cm | 56.8L | SSS | 1 |
| 2322 | Container Open-top, Titanium Surface | 38.1 × 71.1cm | 56.8L | TITA | 1 |
| 2330 | Ashtray/Trash, Mirror Chrome | 38.1 × 72.6cm | 45.4L | SS | 1 |
| 2331 | Ashtray/Trash, Satin Stainless Steel | 38.1 × 72.6cm | 45.4L | SSS | 1 |
| 2332 | Ashtray/Trash, Titanium Surface | 38.1 × 72.6cm | 45.4L | TITA | 1 |
| 2340 | Container Flat-top, Mirror Chrome | 38.1 × 71.1cm | 45.4L | SS | 1 |
| 2341 | Container Flat-top, Satin Stainless Steel | 38.1 × 71.1cm | 45.4L | SSS | 1 |
| 2342 | Container Flat-top, Titanium Surface | 38.1 × 71.1cm | 45.4L | TITA | 1 |
| 2350 | Container Round-top, Mirror Chrome | 38.1 × 76.0cm | 45.4L | SS | 1 |
| 2351 | Container Round-top, Satin Stainless Steel | 38.1 × 76.0cm | 45.4L | SSS | 1 |
| 2352 | Container Round-top, Titanium Surface | 38.1 × 76.0cm | 45.4L | TITA | 1 |
| 2360 | Container Round-top, Mirror Chrome | 38.1 × 91.4cm | 56.8L | SS | 1 |
| 2361 | Container Round-top, Satin Stainless Steel | 38.1 × 91.4cm | 56.8L | SSS | 1 |
| 2362 | Container Round-top, Titanium Surface | 38.1 × 91.4cm | 56.8L | TITA | 1 |
| 2370 | Container Open-top, Mirror Chrome | 25.4 × 38.1cm | 18.9L | SS | 1 |
| 2371 | Container Open-top, Satin Stainless Steel | 25.4 × 38.1cm | 18.9L | SSS | 1 |
| 2372 | Container Open-top, Titanium Surface | 25.4 × 38.1cm | 18.9L | TITA | 1 |



Satin Stainless Steel



Titanium Surface



STEELEDGE® CONTAINERS



PRODUCT FEATURES:

1. Premium containers for use in high-end environments.
2. Eternal design, chromium and copper polished coating, extreme durability to reduce maintenance costs, suitable for high profile display.
3. A perfect collection of sizes and shapes providing a comprehensive solution.
4. Made of heavy-duty fireproof material, extremely durable.
5. Rubber rim effectively reduces damage to the product.
6. Unique base design protects floors.
7. Only for indoor use.
8. Auto closing top and recessed handle facilitate moving and dumping.
9. Leak-proof galvanized steel inner container included.



Dome lid shuts down automatically to prevent the bugs and odor

| Model | Description | Dimensions | Capacity | Color | Pack |
|-------|---|---------------|----------|-----------|------|
| 2314 | Ashtray/Trash, Mirror Foot Circle | 25.4 × 68.6cm | 13.2L | GRAY, BLA | 1 |
| 2315 | Ashtray/Trash, Titanium Foot Circle | 25.4 × 68.6cm | 13.2L | CR, EGRN | 1 |
| 2324 | Container Open-top, Mirror Foot Circle | 38.1 × 71.1cm | 56.8L | GRAY, BLA | 1 |
| 2325 | Container Open-top, Titanium Foot Circle | 38.1 × 71.1cm | 56.8L | CR, EGRN | 1 |
| 2334 | Ashtray/Trash, Mirror Foot Circle | 38.1 × 72.6cm | 45.4L | GRAY, BLA | 1 |
| 2335 | Ashtray/Trash, Titanium Foot Circle | 38.1 × 72.6cm | 45.4L | CR, EGRN | 1 |
| 2344 | Container Flat-top, Mirror Foot Circle | 38.1 × 71.1cm | 45.4L | GRAY, BLA | 1 |
| 2345 | Container Flat-top, Titanium Foot Circle | 38.1 × 71.1cm | 45.4L | CR, EGRN | 1 |
| 2354 | Container Round-top, Mirror Foot Circle | 38.1 × 76.0cm | 45.4L | GRAY, BLA | 1 |
| 2355 | Container Round-top, Titanium Foot Circle | 38.1 × 76.0cm | 45.4L | CR, EGRN | 1 |
| 2364 | Container Round-top, Mirror Foot Circle | 38.1 × 91.4cm | 56.8L | GRAY, BLA | 1 |
| 2365 | Container Round-top, Titanium Foot Circle | 38.1 × 91.4cm | 56.8L | CR, EGRN | 1 |
| 2374 | Container Open-top, Mirror Foot Circle | 25.4 × 38.1cm | 18.9L | GRAY, BLA | 1 |
| 2375 | Container Open-top, Titanium Foot Circle | 25.4 × 38.1cm | 18.9L | CR, EGRN | 1 |



STEELEDGE® CONTAINERS



PRODUCT FEATURES:

1. Made of heavy-duty fireproof material, extreme durability.
2. Powder coated surface.
3. Rubber rim effectively reduces damage to the product.
4. Unique base design protects floors from dispersing.
5. Auto closing heavy duty stainless steel door prevents odor.
6. 2353 and 2363 have recessed handles that facilitate moving and dumping.
7. Included leak-proof inner container is made of galvanized steel.



| Model | Description | Dimensions | Capacity | Color | Pack |
|-------|------------------------------------|---------------|----------|----------------------|------|
| 2313 | Ashtray/Trash, Spray Surface | 25.4 × 68.6cm | 13.2L | BLUE, GRAY, GRN, RED | 1 |
| 2323 | Container Open-top, Spray Surface | 38.1 × 71.1cm | 56.8L | BLUE, GRAY, GRN, RED | 1 |
| 2333 | Ashtray/Trash, Spray Surface | 38.1 × 72.6cm | 45.4L | BLUE, GRAY, GRN, RED | 1 |
| 2343 | Container Flat-top, Spray Surface | 38.1 × 71.1cm | 45.4L | BLUE, GRAY, GRN, RED | 1 |
| 2353 | Container Round-top, Spray Surface | 38.1 × 76.0cm | 45.4L | BLUE, GRAY, GRN, RED | 1 |
| 2363 | Container Round-top, Spray Surface | 38.1 × 91.4cm | 56.8L | BLUE, GRAY, GRN, RED | 1 |
| 2373 | Container Open-top, Spray Surface | 25.4 × 38.1cm | 18.9L | BLUE, GRAY, GRN, RED | 1 |

ALUMINUM TRASH CANS



PRODUCT FEATURES:

1. An ideal choice for airports, office buildings, and shopping centers.
2. Made of heavy-duty aluminum alloy, ensuring corrosion and rust resistance, extreme durability.
3. Special treatments deliver a scratch-proof surface.
4. The concealed trash bag design makes for a clean and tidy appearance.
5. Fire-resistant.



The design of **concealed trash bag** provides a clean and tidy appearance

| Model | Description | Dimensions | Capacity | Color | Pack |
|-------|--------------------|---------------|----------|-------|------|
| 2391 | Aluminum Trash Can | 32.0 × 70.0cm | 45L | MSILV | 1 |
| 2392 | Aluminum Trash Can | 38.0 × 77.5cm | 65L | MSILV | 1 |
| 2393 | Aluminum Trash Can | 45.7 × 81.9cm | 110L | MSILV | 1 |

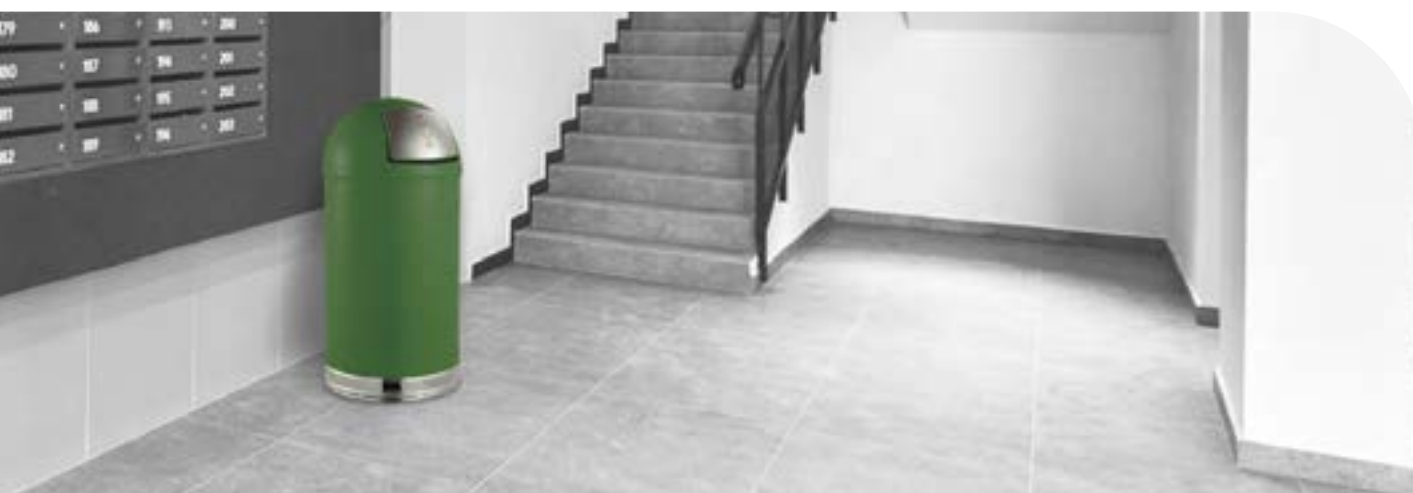

OPEN TRASH CANS

PRODUCT FEATURES:

1. Ideal for use in restaurants, hotels, airports, and train stations.
2. Made of heavy-duty fireproof material, extreme durability.
3. Unique base design protects floors.
4. Leak-proof galvanized steel inner container included.
5. For indoor use.



1318



1319



| Model | Description | Dimensions | Capacity | Color | Pack |
|-------|----------------------|---------------|----------|-------|------|
| 1318 | Domed Open Trash Can | 39.0 × 87.5cm | 50L | BLA | 1 |
| 1319 | Top Open Trash Can | 35.5 × 57.5cm | 40L | SS | 1 |

ROUND STAINLESS STEEL STEP-ON CONTAINERS

PRODUCT FEATURES:

1. Made of heavy-duty fireproof material, extreme durability.
2. Unique base design protects floors.
3. Quiet, heavy-duty pedal for hands-free hygienic use.
4. Soft-close lid prevents noise effectively.
5. Variety of capacity for choosing.
6. For indoor use.



1310



1312



1313



| Model | Description | Dimensions | Capacity | Color | Pack |
|-------|---|---------------|----------|-------|------|
| 1310 | Round Stainless Steel Step-on Container | 20.5 × 32.0cm | 7L | SSS | 1 |
| 1311 | Round Stainless Steel Step-on Container | 25.0 × 40.0cm | 12L | SSS | 1 |
| 1312 | Round Stainless Steel Step-on Container | 29.2 × 45.0cm | 20L | SSS | 1 |
| 1313 | Round Stainless Steel Step-on Container | 29.2 × 64.0cm | 30L | SSS | 1 |



ROUND STAINLESS STEEL STEP-ON CONTAINERS



PRODUCT FEATURES:

1. Made of heavy-duty fireproof material, extreme durability.
2. Hidden handle on the back, convenient for handling.
3. Unique base design protects floors.
4. Quiet, heavy-duty pedal for hands-free hygienic use.
5. Soft-close lid prevents noise effectively.
6. Wide choice of capacity.
7. For indoor use.



| Model | Description | Dimensions | Capacity | Color | Pack |
|-------|---|---------------|----------|-------|------|
| 1322 | Round Stainless Steel Step-on Container | 25.0 × 41.5cm | 12L | SSS | 1 |
| 1323 | Round Stainless Steel Step-on Container | 29.2 × 47.3cm | 20L | SSS | 1 |
| 1324 | Round Stainless Steel Step-on Container | 29.2 × 66.0cm | 30L | SSS | 1 |

ROUND STAINLESS STEEL STEP-ON CONTAINERS



PRODUCT FEATURES:

1. Made of heavy-duty fireproof material, extreme durability.
2. Unique base design protects floors.
3. Quiet, heavy-duty pedal for hands-free hygienic use.
4. Soft-close lid prevents noise effectively.
5. Wide choice of capacity.
6. For indoor use.



| Model | Description | Dimensions | Capacity | Color | Pack |
|-------|---|---------------|----------|-------|------|
| 1325 | Round Stainless Steel Step-on Container | 28.5 × 33.8cm | 12L | SSS | 1 |
| 1326 | Round Stainless Steel Step-on Container | 33.5 × 47.5cm | 20L | SSS | 1 |
| 1327 | Round Stainless Steel Step-on Container | 33.5 × 67.2cm | 30L | SSS | 1 |



SVELTE® STAINLESS STEEL STEP-ON CONTAINERS



PRODUCT FEATURES:

1. The slim rectangle shape is space efficient and fits tight spaces.
2. Made of heavy-duty fireproof material, extreme durability.
3. Hidden handle on the back, convenient for handling.
4. Unique base design protects floors.
5. Quiet, heavy-duty pedal for hands-free hygienic use.
6. Soft-close lid prevents noise effectively.
7. For indoor use.



Soft-close lid prevent noise effectively



1314



1315



1316



1317

| Model | Description | Dimensions | Capacity | Color | Pack |
|-------|---|----------------------|----------|-------|------|
| 1314 | SVELTE® Stainless Steel Step-on Container | 34.0 × 32.0 × 60.8cm | 30L | SSS | 1 |
| 1315 | SVELTE® Stainless Steel Step-on Container | 42.6 × 37.2 × 63.5cm | 50L | SSS | 1 |
| 1316 | SVELTE® Stainless Steel Step-on Container | 38.0 × 35.0 × 66.0cm | 40L | SSS | 1 |
| 1317 | SVELTE® Stainless Steel Step-on Container | 51.5 × 25.0 × 64.0cm | 45L | SSS | 1 |

SEMICIRCULAR STAINLESS STEEL STEP-ON TRASH CANS



PRODUCT FEATURES:

1. Semicircular design can be put close to the wall to save space.
2. Unique base design protects floors.
3. Hidden handle on the back, convenient for handling.
4. Quiet, heavy-duty pedal for hands-free hygienic use.
5. Soft-close lid prevents noise effectively.
6. For indoor use.



Hidden handle on the back for easy handling



1320



1321

| Model | Description | Dimensions | Capacity | Color | Pack |
|-------|--|----------------------|----------|-------|------|
| 1320 | Semicircular Stainless Steel Step-on Trash Can | 30.0 × 28.5 × 40.5cm | 12L | SSS | 1 |
| 1321 | Semicircular Stainless Steel Step-on Trash Can | 39.0 × 36.0 × 67.5cm | 40L | SSS | 1 |

NEATACE® CLASSIC HANDS-FREE TRASH CANS

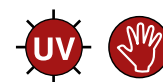

PRODUCT FEATURES:

1. Classic and simple style, suitable for places with a variety of architectural styles.
2. Durable molded construction with smooth surfaces, easy to clean.
3. Concealed trash bag design makes for a clean and tidy appearance.



2208

2209

2213

| Model | Description | Dimensions | Capacity | Color | Pack |
|-------|--|--------------------|----------|-----------|------|
| 2202 | NEATACE® Trash Can, Ashtray Top Cover without Valves | Dia 38.0 × 93.0cm | 56L | BEIG, BLA | 1 |
| 2203 | NEATACE® Trash Can, Open Top Cover | Dia 38.0 × 76.0cm | 56L | BEIG, BLA | 1 |
| 2205 | NEATACE® Trash Can, Spherical Top Cover, Top Open | Dia 38.0 × 91.5cm | 56L | BEIG, BLA | 1 |
| 2208 | NEATACE® Trash Can, Ashtray Top Cover without Valves | Dia 43.9 × 107.0cm | 95L | BEIG, BLA | 1 |
| 2209 | NEATACE® Trash Can, Open Top Cover | Dia 43.9 × 85.0cm | 95L | BEIG, BLA | 1 |
| 2213 | NEATACE® Trash Can, Spherical Top Cover, Top Open | Dia 43.9 × 104.8cm | 95L | BEIG, BLA | 1 |

NEATACE® CLASSIC TRASH CANS



PRODUCT FEATURES:

1. Classic and simple style, suitable for places with a variety of architectural styles.
2. Durable molded construction with smooth surfaces, easy to clean.
3. Concealed trash bag design makes for a clean and tidy appearance.
4. Hinged opening makes garbage disposal easier with the shutter automatically closing - effectively controlling odors and preventing the entry of mosquitoes and flies.



2206

2207

2210

| Model | Description | Dimensions | Capacity | Color | Pack |
|-------|---|--------------------|----------|-----------|------|
| 2200 | NEATACE® Trash Can, Dome Cover | Dia 38.0 × 92.7cm | 56L | BEIG, BLA | 1 |
| 2201 | NEATACE® Trash Can, Ashtray Top Cover with Valves | Dia 38.0 × 93.0cm | 56L | BEIG, BLA | 1 |
| 2204 | NEATACE® Trash Can, Spherical Top Cover | Dia 38.0 × 92.7cm | 56L | BEIG, BLA | 1 |
| 2206 | NEATACE® Trash Can, Dome Cover | Dia 43.9 × 106.6cm | 95L | BEIG, BLA | 1 |
| 2207 | NEATACE® Trash Can, Ashtray Top Cover with Valves | Dia 43.9 × 107.0cm | 95L | BEIG, BLA | 1 |
| 2210 | NEATACE® Trash Can, Spherical Top Cover | Dia 43.9 × 106.6cm | 95L | BEIG, BLA | 1 |

RISTON® DECORATIVE CONTAINERS



PRODUCT FEATURES:

1. Ideal for use in building entrances, lobbies and shopping malls.
2. Attractive design with side-door for easy cleaning.
3. Durable molded construction with smooth surfaces, easy to clean.
4. Hinged opening makes garbage disposal easier with the shutter automatically closing - effectively controlling odors and preventing the entry of mosquitoes and flies.
5. Can be fixed to the ground with screws.
6. Built-in tray holder on top of 2103 for trays of 38 × 51cm.
7. Built-in garbage bag holder, convenient to fix the garbage bag.
8. Optional hard inner bins, suitable for storing sharp and heavy waste.



Built-in tray holder on top of model 2103 for trays of 38 × 51cm



| Model | Description | Dimensions | Capacity | Color | Pack |
|-------|---|-----------------------|----------|----------------|------|
| 2101 | RISTON® Decorative Container | 62.9 × 64.0 × 107.0cm | 190L | GRN, BEIG, BLA | 1 |
| 2102 | RISTON® Decorative Container, Ashtray Top | 62.9 × 64.0 × 107.0cm | 190L | GRN, BEIG, BLA | 1 |
| 2103 | RISTON® Decorative Container, Tray Top | 62.9 × 64.0 × 107.0cm | 190L | BEIG, BLA | 1 |
| 2106 | RISTON® Decorative Container | 54.4 × 51.6 × 104.0cm | 132L | GRN, BEIG, BLA | 1 |
| 2107 | RISTON® Decorative Container, Ashtray Top | 54.4 × 51.6 × 104.0cm | 132L | GRN, BEIG, BLA | 1 |
| 1281 | Rigid Liner, for 2106/2107 | 36.6 × 36.6 × 71.0cm | 75L | GRAY | 4 |
| 1282 | Rigid Liner, for 2101/2102/2103 | 49.5 × 49.5 × 70.2cm | 132L | GRAY | 4 |

BEAUCAN® OUTDOOR DECORATIVE TRASH CANS

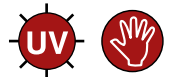

PRODUCT FEATURES:

1. Designed for stadiums, parks, shopping malls, and other high-traffic areas.
2. Durable molded construction with smooth surfaces, easy to clean.
3. Permanently attached hinged lid for easy emptying.
4. Metal retainers keep can liners securely in place and eliminate knot tying.
5. Stable base to increase stability.
6. 2111 with double sided movable flaps, effectively controlling odor overflow and preventing the entry of mosquitoes and flies.
7. 2112 four-sided opening, suitable for places with high traffic.
8. Optional hard inner bins, suitable for storing sharp and heavy waste.



Permanently attached hinged lid for easy emptying

| Model | Description | Dimensions | Capacity | Color | Pack |
|-------|---|-----------------------|----------|----------------|------|
| 2111 | BEAUCAN® Decorative Trash Can, Two Sides of Movable Doors | 63.2 × 63.2 × 105.4cm | 170L | BEIG, BLA | 1 |
| 2112 | BEAUCAN® Decorative Trash Can, Four-sided Openings | 63.2 × 63.2 × 105.4cm | 170L | BEIG, BLA | 1 |
| 2113 | BEAUCAN® Decorative Trash Can, Double Sided Movable Flaps | 54.6 × 54.6 × 104.0cm | 132L | BEIG, BLA, BRN | 1 |
| 1282 | Rigid Liner, for 2111/2112 | 49.5 × 49.5 × 70.2cm | 132L | GRAY | 4 |
| 1284 | Rigid Liner, for 2113 | 41.2 × 41.2 × 72.4cm | 90L | GRAY | 4 |



DECORATIVE WASTE CONTAINERS



Terminator® Cigarette Butt Buckets

Exquisite design, metal construction, beautiful and efficient cigarette butt management solution.

- Innovative patented structure allows for easy emptying without additional tools.
- Elegant and durable, made from aviation aluminum alloy to ensure corrosion and rust resistance.
- Heavy base and fixtures provide high stability and security for outdoor use.
- Locking device effectively prevents vandalism and theft.
- Excellent sealing helps extinguish cigarette butts.

Complete Solutions for a Variety of Locations

- Restaurants and Bars
- Shopping Centers
- Office Buildings
- Playgrounds and Parks
- Airports, Bus and Railway Stations
- Health Facilities
- Hotels and Resorts
- Clubs
- Manufacturing Plants
- Convention and Exhibition Centers



TERMINATOR® FLOOR-STANDING CIGARETTE BUTT BUCKETS

PRODUCT FEATURES:

1. Designed with large capacity, an ideal cigarette butt collector in stadiums, gymnasiums, parks, hotels, office buildings and public places.
2. Elegant and durable, made from aviation aluminum alloy to ensure corrosion and rust resistance.
3. Stylish modern design is suitable for a variety of architectural styles.
4. Heavy base and fixtures provide high stability and security for outdoor use.
5. Liner with excellent sealing immediately extinguishes cigarette butts.
6. Allows for simple and fast emptying.



Open the cigarette butts bucket with a key to remove the liner



Open the bottom of the liner to empty the cigarette butts



2261

2271

2281

2291

| Model | Description | Dimensions | Capacity | Cigarette Butts Number | Color | Pack |
|-------|---|-----------------------|----------|------------------------|-------|------|
| 2261 | TERMINATOR® Floor-standing Cigarette Butts Bucket | 30.0 × 90.0cm | 6.7L | 1900 | MSILV | 1 |
| 2271 | TERMINATOR® Floor-standing Cigarette Butts Bucket | 30.0 × 104.0cm | 9.8L | 2800 | MSILV | 1 |
| 2281 | TERMINATOR® Floor-standing Cigarette Butts Bucket | 30.0 × 30.0 × 125.0cm | 6.9L | 2000 | MSILV | 1 |
| 2291 | TERMINATOR® Floor-standing Cigarette Butts Bucket | 37.0 × 30.0 × 138.0cm | 6.9L | 2000 | MSILV | 1 |

TERMINATOR® WALL-MOUNTED CIGARETTE BUTTS BUCKETS

PRODUCT FEATURES:

1. Suitable for smoking areas either outdoor or indoor.
2. Elegant and durable, made from aviation aluminum alloy to ensure corrosion and rust resistance.
3. Stylish modern design is suitable for a variety of architectural styles.
4. Excellent sealing assists immediately extinguishing cigarette butts.
5. Allows for simple and fast emptying.



2211



2221

| Model | Description | Dimensions | Capacity | Cigarette Butts Number | Color | Pack |
|-------|---|--------------------|----------|------------------------|-------|------|
| 2211 | TERMINATOR® Wall-mounted Cigarette Butts Bucket | 8.0 × 8.0 × 48.0cm | 2.5L | 700 | MSILV | 1 |
| 2221 | TERMINATOR® Wall-mounted Cigarette Butts Bucket | 8.0 × 8.0 × 48.0cm | 2.5L | 700 | MSILV | 1 |

TERMINATOR® WALL-MOUNTED CIGARETTE BUTTS BUCKETS

PRODUCT FEATURES:

1. Suitable for smoking areas either outdoor or indoor.
2. Elegant and durable, made from aviation aluminum alloy to ensure corrosion and rust resistance.
3. Stylish modern design is suitable for a variety of architectural styles.
4. Excellent sealing assists immediately extinguishing cigarette butts.
5. Allows for simple and fast emptying.



2231



2241



| Model | Description | Dimensions | Capacity | Cigarette Butts Number | Color | Pack |
|-------|---|--------------|----------|------------------------|-------|------|
| 2231 | TERMINATOR® Wall-mounted Cigarette Butts Bucket | 8.0 × 48.0cm | 1.8L | 550 | MSILV | 1 |
| 2241 | TERMINATOR® Wall-mounted Cigarette Butts Bucket | 8.0 × 48.0cm | 1.8L | 550 | MSILV | 1 |

TERMINATOR® WALL-MOUNTED CIGARETTE BUTTS BUCKETS

PRODUCT FEATURES:

1. Suitable for smoking areas either outdoor or indoor.
2. Titanium alloy cover, fine and stylish, for use in the high-end facilities.
3. Stylish modern design is suitable for a variety of architectural styles.
4. Excellent seal assists immediate extinguishing of cigarette butts.
5. Allows for simple and fast emptying.



2212



2242

| Model | Description | Dimensions | Capacity | Cigarette Butts Number | Color | Pack |
|-------|---|--------------------|----------|------------------------|-------|------|
| 2212 | TERMINATOR® Wall-mounted Cigarette Butts Bucket | 8.0 × 8.0 × 48.0cm | 1.8L | 550 | TITA | 1 |
| 2242 | TERMINATOR® Wall-mounted Cigarette Butts Bucket | 8.0 × 48.0cm | 1.3L | 400 | TITA | 1 |



Smoking Area



TERMINATOR® FLOOR-STANDING CIGARETTE BUTT BUCKETS

PRODUCT FEATURES:

1. Designed with large capacity, an ideal cigarette butt collector in stadiums, gymnasiums, parks, hotels, office buildings and public places.
2. Innovative unibody design; collects small sized litter conveniently.
3. Elegant and durable, made from aviation aluminum alloy to ensure corrosion and rust resistance.
4. Stylish modern design is suitable for a variety of architectural styles.
5. Heavy base and fixtures provide high stability and security for outdoor use.
6. Liner with excellent sealing immediately extinguishes cigarette butts.
7. Allows for simple and fast emptying.



2262

| Model | Description | Dimensions | Capacity | Cigarette Butts Number | Color | Pack |
|-------|---|----------------------|----------|------------------------|-------|------|
| 2262 | TERMINATOR® Floor-standing Cigarette Butts Bucket | 45.0 × 30.0 × 90.0cm | 6.7L | 1900 | MSILV | 1 |

TERMINATOR® LARGE-CAPACITY CIGARETTE BUTT BUCKETS

PRODUCT FEATURES:

1. Ideal cigarette butt collection for smoking areas.
2. Elegant and durable, made from aviation aluminum alloy to ensure corrosion and rust resistance.
3. Stylish modern design is suitable for a variety of architectural styles.
4. Side opening available for collection of cigarette packs and other small garbage.



Removable large capacity

Cigarette butt liner has a cigarette pack entrance for added versatility



2251

| Model | Description | Dimensions | Capacity | Cigarette Butts Number | Color | Pack |
|-------|---|---------------|----------|------------------------|-------|------|
| 2251 | TERMINATOR® Large-capacity Cigarette Butts Bucket | 21.0 × 80.0cm | 1L | 280 | MSILV | 1 |

STEELEDGE® CIGARETTE BARRELS

PRODUCT FEATURES:

1. Ideal for use in hotels, clubs and office buildings.
2. Made of heavy-duty fireproof material, extremely durable.
3. Unique base design protects floors.
4. Fine, high-end surface treatment.



| Model | Description | Dimensions | Capacity | Color | Pack |
|-------|---|---------------|----------|----------------------|------|
| 2300 | Cigarette Barrel, Mirror Chrome | 25.4 × 51.0cm | N/A | SS | 1 |
| 2301 | Cigarette Barrel, Satin Stainless Steel | 25.4 × 51.0cm | N/A | SSS | 1 |
| 2302 | Cigarette Barrel, Titanium Surface | 25.4 × 51.0cm | N/A | TITA | 1 |
| 2303 | Cigarette Barrel, Spray Surface | 25.4 × 51.0cm | N/A | BLUE, GRAY, GRN, RED | 1 |
| 2304 | Cigarette Barrel, Mirror Foot Circle | 25.4 × 51.0cm | N/A | GRAY, BLA | 1 |
| 2305 | Cigarette Barrel, Titanium Foot Circle | 25.4 × 51.0cm | N/A | CR, EGRN | 1 |

STEELEDGE® ASHTRAY/TRASHES

PRODUCT FEATURES:

1. Ideal for the use in hotels, clubs and office buildings.
2. Made of heavy-duty fireproof material, extreme durable.
3. Rubber rim effectively reduces damage to the product.
4. Unique base design protects floors.
5. Included leak-proof inner container is made from galvanized steel.



| Model | Description | Dimensions | Capacity | Color | Pack |
|-------|--------------------------------------|---------------|----------|----------------------|------|
| 2310 | Ashtray/Trash, Mirror Chrome | 25.4 × 68.6cm | 13.2L | SS | 1 |
| 2311 | Ashtray/Trash, Satin Stainless Steel | 25.4 × 68.6cm | 13.2L | SSS | 1 |
| 2312 | Ashtray/Trash, Titanium Surface | 25.4 × 68.6cm | 13.2L | TITA | 1 |
| 2313 | Ashtray/Trash, Spray Surface | 25.4 × 68.6cm | 13.2L | BLUE, GRAY, GRN, RED | 1 |
| 2314 | Ashtray/Trash, Mirror Foot Circle | 25.4 × 68.6cm | 13.2L | GRAY, BLA | 1 |
| 2315 | Ashtray/Trash, Titanium Foot Circle | 25.4 × 68.6cm | 13.2L | CR, EGRN | 1 |
| 2330 | Ashtray/Trash, Mirror Chrome | 38.1 × 72.6cm | 45.4L | SS | 1 |
| 2331 | Ashtray/Trash, Satin Stainless Steel | 38.1 × 72.6cm | 45.4L | SSS | 1 |
| 2332 | Ashtray/Trash, Titanium Surface | 38.1 × 72.6cm | 45.4L | TITA | 1 |
| 2333 | Ashtray/Trash, Spray Surface | 38.1 × 72.6cm | 45.4L | BLUE, GRAY, GRN, RED | 1 |
| 2334 | Ashtray/Trash, Mirror Foot Circle | 38.1 × 72.6cm | 45.4L | GRAY, BLA | 1 |
| 2335 | Ashtray/Trash, Titanium Foot Circle | 38.1 × 72.6cm | 45.4L | CR, EGRN | 1 |





THOR® RIM CADDIES

PRODUCT FEATURES:

1. Snaps securely onto rim of 166L round container (1014).
2. Built-in bag straps allow for easy poly liner attachment.
3. User-friendly handle improves maneuverability and minimizes contact with refuse.
4. Provides storage for spray bottles, safety signs, cleaning sponges, lobby dust pan, brushes, liners, gloves etc.
5. Made of tough and durable plastic.
6. Smooth surfaces allow for easy cleaning.



1821



1014/1821/1811

| Model | Description | Dimensions | Capacity | Color | Pack |
|-------|--|----------------------|----------|-------|------|
| 1014 | THOR® Round Container | 61.0 × 80.0cm | 166L | GRAY | 4 |
| 1811 | THOR® Dolly for 1010/1012/1013/1014/1015 | 46.4 × 16.8cm | N/A | BLA | 2 |
| 1821 | THOR® Rim Caddy for 1014 | 88.2 × 70.3 × 17.0cm | N/A | YEL | 1 |

THOR® CADDY BAGS

PRODUCT FEATURES:

1. Nylon reinforced vinyl bags are durable and easy to maintain cleanliness.
2. Pockets of various sizes are available for placing various cleaning supplies.



1014/1831/1811

| Model | Description | Dimensions | Capacity | Color | Pack |
|-------|-------------------------------|-------------------|----------|-------|------|
| 1831 | THOR® Caddy Bag for 1013/1014 | Dia 50.8 × 52.1cm | N/A | YEL | 6 |

CARRY CADDIES

PRODUCT FEATURES:

1. Perfect for carrying tools or cleaning supplies.
2. Securely fits on to the brim of 121L (1013) Round Container.
3. User friendly handles fit your hand and allow for a comfortable grip.
4. Securely holds Spray Bottles (6947) and other common cleaning tools.
5. Allows for stable stacking to save space.
6. Rounded corners ensure safety and prevent against injury.

SIGNBOARD HOOKS

PRODUCT FEATURES:

1. An ideal solution for hanging Floor Safety Signs (7114, 7161, 7162, 7163).
2. Tightening lock positioned on the brim of 121L Round Container (1013).
3. Made of sturdy, durable plastics.



1823



1822



| Model | Description | Dimensions | Capacity | Color | Pack |
|-------|----------------|----------------------|----------|-------|------|
| 1822 | Signboard Hook | 15.3 × 10.0 × 6.0cm | N/A | BLA | 6 |
| 1823 | Carry Caddy | 37.5 × 32.0 × 18.0cm | N/A | BLA | 4 |

THOR® DOLLIES

PRODUCT FEATURES:

1. Easy mobility and maneuverability of heavy loads.
2. Swivel casters offer easy mobility.
3. Attach trash containers with ease.



Foot fixing position, easy loading and unloading



1811



1812



1813



1818

| Model | Description | Dimensions | Capacity | Color | Pack |
|-------|--|-----------------------|----------|-------|------|
| 1811 | THOR® Dolly for 1010/1012/1013/1014/1015 | 46.4 × 16.8cm | N/A | BLA | 2 |
| 1812 | THOR® Square Dolly for 1231/1233 | 43.8 × 15.9cm | N/A | BLA | 2 |
| 1813 | THOR® Quiet Dolly for 1010/ 1012/1013/1014/1015 | 46.4 × 16.8cm | N/A | BLA | 2 |
| 1818 | THOR® Drum Dolly for 1010/1012/ 1013/1014/1015/1231/1233 | 114.3 × 51.4 × 20.3cm | N/A | BLA | 1 |



SVELTE® RIM CADDIES & DOLLIES



PRODUCT FEATURES:

1. The combined cleaning system is composed of Svelte® trolley, Svelte® trash can and Svelte® tool assembly rack, which is convenient and efficient to collect garbage and carry cleaning tools.
2. The slim rectangle shape is space efficient and fits tight spaces.
3. Convenient for sorting collection.
4. Svelte® Dollies (1825), sturdy structural foam construction won't rust, dent, chip, or peel; 7.5cm non-marking castors - prevent floor marking and reduce post-job clean up.
5. When used with the connection device (1826), the two trolleys can be firmly connected together to improve work efficiency.

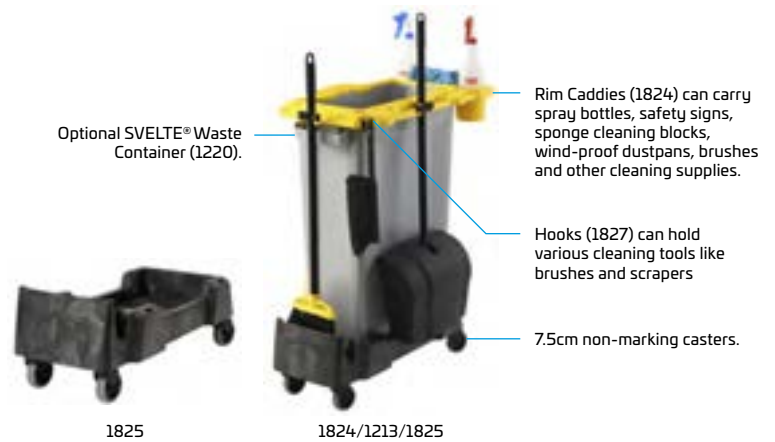

Rim Caddies (1824) hold a safety sign



Rim Caddies (1824) can secure two garbage bags on the rim for efficient classification collection



Rim Caddies (1824) elastic clamp can hold broom and mop handles with diameter 2.2 to 2.9cm



Dolly Connectors (1826) connects several dollies for collection and transportation purposes

| Model | Description | Dimensions | Capacity | Color | Pack |
|-------|--------------------------------------|----------------------|----------|------------|------|
| 1213 | SVELTE® Container | 57.0 × 27.2 × 75.6cm | 87L | BLA, LGRAY | 4 |
| 1220 | SVELTE® Container | 51.3 × 27.2 × 75.6cm | 87L | BLA, LGRAY | 4 |
| 1814 | SVELTE® Dolly for 1211/1213/1220 | 51.6 × 29.0 × 26.0cm | N/A | BLA | 2 |
| 1824 | SVELTE® Rim Caddy for 1211/1213/1220 | 74.6 × 37.6 × 11.9cm | N/A | YEL, BLA | 1 |
| 1825 | SVELTE® Dolly for 1211/1213/1220 | 63.5 × 30.0 × 24.6cm | N/A | BLA | 2 |
| 1826 | SVELTE® Connector for 1825 | 15.9 × 10.9 × 11.4cm | N/A | BLA | 1 |

SVELTE® CADDY BAGS SVELTE® HOOKS

PRODUCT FEATURES:

1. Nylon reinforced vinyl bags are durable and easy to maintain cleanliness.
2. Pockets of various sizes are available for placing various cleaning supplies.
3. Used with Svelte® trash can and Svelte® trolley (1814, 1825) provides a convenient and efficient method to collect garbage and carry cleaning tools.

PRODUCT FEATURES:

1. Tightening lock on the brim of Rim Caddies (1824).
2. Suitable for hanging all kinds of cleaning tools.
3. Made of sturdy, durable plastics.



1827



1828/1213/1825

| Model | Description | Dimensions | Capacity | Color | Pack |
|-------|----------------------------|-------------------|----------|----------|------|
| 1827 | SVELTE® Hook for 1824 | 4.3 × 3.6 × 4.2cm | N/A | YEL, BLA | 4 |
| 1828 | SVELTE® Caddy Bag for 1213 | 50.0 × 48.0cm | N/A | YEL, BLA | 2 |

WASTE CLASSIFICATION SYMBOLS



PRODUCT FEATURES:

1. Helpful for waste classification.
2. Self-adhesive PVC sticker, easy to attach and scrub-resistant.

| Model | Description | Dimensions | Pack |
|-------|--|---------------|------|
| 1940 | "Recyclable Waste" Label | 13.0 × 23.0cm | 10 |
| 1941 | "Soil" Label | 13.0 × 23.0cm | 10 |
| 1942 | "Building Materials" Label | 13.0 × 23.0cm | 10 |
| 1943 | "Garden Waste" Label | 13.0 × 23.0cm | 10 |
| 1944 | "Food Waste" Label | 13.0 × 23.0cm | 10 |
| 1945 | "Paint" Label | 13.0 × 23.0cm | 10 |
| 1946 | "Household and Garden Chemicals" Label | 13.0 × 23.0cm | 10 |
| 1947 | "Mixed Paper and Card" Label | 13.0 × 23.0cm | 10 |
| 1948 | "Plastics" Label | 13.0 × 23.0cm | 10 |
| 1949 | "Mixed Textiles and Clothes" Label | 13.0 × 23.0cm | 10 |
| 1950 | "Mixed Glass" Label | 13.0 × 23.0cm | 10 |
| 1951 | "Metal" Label | 13.0 × 23.0cm | 10 |
| 1952 | "Batteries" Label | 13.0 × 23.0cm | 10 |



Helpful for waste classification and management.

SVELTE® DOLLIES

PRODUCT FEATURES:

1. Sturdy structural foam construction will not rust, dent or chip.
2. 7.5cm non-marking casters.
3. Easy mobility and maneuverability of heavy loads.
4. Multi-compartment dollies can easily move multiple containers and facilitate waste classification.



| Model | Description | Dimensions | Capacity | Color | Pack |
|-------|---|-----------------------|----------|-------|------|
| 1814 | SVELTE® Dolly, for 1211/1212/1213/1214/1220/1221 | 51.6 × 29.0 × 26.0cm | N/A | BLA | 2 |
| 1815 | SVELTE® Double-compartment Dolly, for 1211/1212/1213/1214/1220/1221 | 58.2 × 51.7 × 24.0cm | N/A | BLA | 1 |
| 1816 | SVELTE® Tri-compartment Dolly, for 1211/1212/1213/1214/1220/1221 | 87.3 × 51.7 × 24.0cm | N/A | BLA | 1 |
| 1817 | SVELTE® Four-compartment Dolly, for 1211/1212/1213/1214/1220/1221 | 116.4 × 51.7 × 24.0cm | N/A | BLA | 1 |





CLEANING CARTS

| | |
|---|----|
| Grandmaid® Housekeeping Carts | 68 |
| Pinnacle® Intelligent Housekeeping Cart | 72 |
| Cleabox® Room Service Carts | 74 |
| Grandmaid® Cleaning Carts | 76 |

CLEANING CART COMBINATION

| | |
|---|----|
| Svelte® Rim Caddies, Dollies & Caddy Bags | 78 |
| Thor® Rim Caddies & Caddy Bags | 79 |
| Svelte® Hooks | 79 |
| Carry Caddies | 80 |
| Signboard Hooks | 80 |
| Collapsible Linen Carts | 81 |
| Cover | 81 |
| X Type Linen Carts | 82 |

MOPPING SYSTEMS

| | |
|---|----|
| All-in-one Buckets | 84 |
| Grandmaid® Press Combos and Accessories | 85 |
| Pedal Mop Wringers | 88 |

Pail and Mop Strainer Combinations

| | |
|-------------------|----|
| Double Pails | 89 |
| Steel Sponge Mops | 89 |
| Buckets | 90 |

WET MOPS

| | |
|----------------------------|----|
| Wet Mop Selection Guide | 92 |
| Blend Mops | 94 |
| Cotton Mops | 94 |
| Superfine Fiber Mops | 94 |
| Economy Cotton Mops | 95 |
| Finish Mops | 95 |
| Clean Room Mops | 95 |
| Superfine Fiber Mops | 96 |
| Microfiber Mops | 96 |
| Quick Connect Mops | 97 |
| Synthetic Fiber Mops | 98 |
| Antibiotic Blended Mops | 98 |
| Antibiotic Microfiber Mops | 98 |

WET MOP HANDLES

| | |
|---------------------------------------|-----|
| Wet Mop Handles | 100 |
| Naelc® Aluminum Quick Connect Handles | 101 |

DUST MOPS

| | |
|---|-----|
| Dust Mop Selection Guide | 102 |
| Naelc® Quick Connect Handles and Frames | 103 |
| Naelc® Dust Mops | 104 |
| Naelc® Dry Mops | 104 |
| Naelc® Wet Mops | 104 |
| Naelc® Dust Mop Handles and Frames | 105 |
| Naelc® Dust Mops | 105 |
| Wedge Dust Mops | 105 |

MICROFIBER CLEANING SYSTEM

| | |
|-------------------------------------|-----|
| Microfiber Technology | 106 |
| U-Rag® Microfiber Cloths | 108 |
| U-Rag® Superfine Fiber Cloths | 109 |
| U-Rag® Microfiber Mitts and Dusters | 109 |
| Laundry Nets | 110 |



BROOMS AND BRUSHES

| | |
|--------------------------------|-----|
| Brooms and Brushes Components | 112 |
| Angle Brooms | 114 |
| Floor Sweeps | 114 |
| Toilet Brushes | 118 |
| Wire Brushes | 118 |
| Counter Brushes | 119 |
| Plastic Handle Utility Brushes | 119 |
| Scrub Brushes | 120 |
| Wash Brushes | 120 |
| Broom Handles | 121 |
| Toilet Brushes | 122 |
| Scouring Pad Cleaning Systems | 123 |
| Corn Brooms | 124 |
| Condenser Cleaning Brushes | 124 |
| Dusting Brushes | 124 |
| Shoe Brushes | 125 |
| Pipe Brushes | 125 |

DUST PANS

| | |
|-----------------------------|-----|
| Predator® Upright Dust Pans | 126 |
| Dust Pans | 127 |
| Step&Sweep Dust Pans | 127 |

FLOOR SQUEEGEES

| | |
|--------------------------------|-----|
| Traditional Floor Squeegees | 128 |
| Dual Moss Squeegees | 128 |
| Professional Plastic Squeegees | 129 |

DUSTING TOOLS

| | |
|--|-----|
| Dusters | 130 |
| Overhead Dusting Tool with Flexible Head | 130 |
| Wall Washer Kits | 131 |

AUXILIARY CLEANING TOOLS

| | |
|---------------------------------|-----|
| Cleaning Tool Holders | 132 |
| Ironing Organizers | 133 |
| Cleaning and Maintenance Gloves | 133 |
| Professional Kneepads | 133 |

| | |
|---------------------------|-----|
| Stepstools | 134 |
| Rotomolded Plastic Pedals | 134 |
| Ladders | 135 |
| Deluxe Carry Caddies | 136 |
| Nozzle and Spray Bottles | 137 |
| Pneumatic Sprayers | 137 |
| Nippers | 138 |
| Toilet Pumps | 138 |
| Scrapers | 138 |

WASHROOM

| | |
|--|-----|
| Heimdall® Baby Changing Stations | 140 |
| Kid&Cool® Microban® Infant Safety Seats | 141 |
| Wall-mounted Sanitary Napkin Receptacles | 142 |
| Feminine Sanitary Bins | 142 |
| Bath Mats | 142 |



Professional Cleaning

At TRUST we are committed to improving cleaning efficiency and to developing high quality products for professional cleaning. Our products have been rigorously tested to be durable, saving your time and money.

Efficient Microfiber Cleaning

High quality microfiber material improves sterilization efficacy and reduces costs.

Innovative Solutions

Our professional cleaning solutions provide you with superior performance.



Introducing the **PINNACLE® SMART ELECTRIC ROOM SERVICE CART**

Innovative product design which provides you with a complete solution to meet all your room service needs. The Pinnacle® Electric Room Service Cart is equipped with intelligent and easy to operate functions. There are various accessories available, which help to improve the work flow and efficiency.

TRUST provides you with a variety of room service carts to meet your needs in different places. Please contact your local dealer for more details.



**Various accessories
available**



GRANDMAID® HOUSEKEEPING CARTS



PRODUCT FEATURES:

1. A complete system solution for housekeeping in hotels.
2. Durable molded construction with smooth surfaces, easy to clean.
3. 20cm wheels make moving easier.
4. User friendly handles are easy to grip and help to maneuver the cart.
5. Bumpers available at four corners to protect walls and equipment.
6. Full size cabinet offers exceptional storage space and adjustable middle shelf.



Built-in hook for hanging various tools and bags



Innovative hook makes hanging tissue paper and cleaning cloths easy

User friendly handles are easy and comfortable to grip and help maneuver the cart



CHOOSE SUITABLE ACCESSORIES

Various accessories to choose from to efficiently and easily cope with different work needs. Enhance your image and satisfy high-end service needs.



| Model | Description | Dimensions | Capacity | Color | Pack |
|-------|---|------------------------|----------|-----------|------|
| 5021 | GRANDMAID® Housekeeping Cart | 152.4 × 55.9 × 127.0cm | N/A | BLA, PLAT | 1 |
| 5022 | GRANDMAID® Housekeeping Cart with Doors | 152.4 × 55.9 × 127.0cm | N/A | BLA | 1 |
| 5023 | GRANDMAID® Housekeeping Cart with Doors, Protective Security Hood | 152.4 × 55.9 × 157.0cm | N/A | BLA | 1 |

ACCESSORIES



Lockable door assembly (5026) for safe and concealed storage of supplies

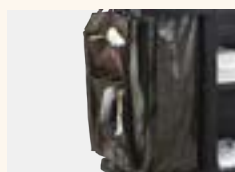

Nine-compartment bag (6975) can carry spray bottles, cleaning cloths, brushes and other cleaning supplies

| Model | Description | Dimensions | Capacity | Color | Pack |
|-------|--|----------------------|----------|-----------|------|
| 5027 | Protective Security Hood for 5021/5022/5023/5031 | 80.6 × 51.5 × 44.5cm | N/A | BLA, PLAT | 1 |
| 5028 | Cover, Compatible with 6968/6974/6977 | 47.1 × 29.1 × 2.1cm | N/A | BLA, PLAT | 2 |
| 5029 | Amenity Organizer | 49.5 × 30.8 × 6.0cm | N/A | BLA | 6 |
| 5030 | Amenity Organizer | 49.5 × 30.8 × 6.0cm | N/A | BLA | 6 |
| 5039 | Protective Security Hood for 5021/5022/5023/5031 | 80.6 × 51.5 × 37.0cm | N/A | BLA | 1 |
| 5056 | Garbage Classification Fixed Frame (1/2 Separated) for 5021/5022/5023/5031 | 45.7 × 28.0 × 3.3cm | N/A | BLA | 1 |
| 5057 | Garbage Classification Fixed Frame (1/3 and 2/3 Separated) for 5021/5022/5023/5031 | 45.7 × 28.0 × 3.3cm | N/A | BLA | 1 |
| 5067 | Safety Shield | 80.3 × 52.8 × 36.6cm | N/A | BLA, PLAT | 1 |
| 5077 | Safety Shield, No Fipped Door | 80.3 × 52.8 × 36.6cm | N/A | BLA, PLAT | 1 |
| 4851 | Utility Sliding Drawer | 65.7 × 43.0 × 8.2cm | N/A | BLA, BRN | 1 |
| 5024 | Adjustable Shelf Kit for 5021/5022/5023/5031 | 76.5 × 47.0 × 5.7cm | N/A | BLA, PLAT | 1 |
| 5026 | Locking Door Kit for 5021/5022/5023 | 86.4 × 44.8 × 4.5cm | N/A | BLA, BRN | 1 |
| 6953 | Three-sided Multi-layer Storage Bag for 5021/5022/5023 | 44.0 × 26.5 × 82.0cm | N/A | BRN | 2 |
| 6954 | Large Capacity of Side Hanging Bag for 5021/5022/5023/5031 | 88.0 × 31.5cm | N/A | BRN | 6 |
| 6972 | Vinyl Bag for 5021/5022/5023 | 83.8 × 26.7 × 42.7cm | N/A | BRN | 6 |
| 6973 | Canvas Linen Accessory Bag for 5021/5022/5023 | 83.8 × 26.7 × 42.7cm | N/A | BRN | 6 |
| 6974 | Fabric Mesh Linen Bag for 5021/5022/5023 | 83.8 × 26.7 × 42.9cm | N/A | BRN | 6 |
| 6975 | Fabric 9-pocket Organizer for 5021/5022/5023/5031 | 71.1 × 50.2 × 3.8cm | N/A | BRN | 6 |
| 6976 | Short Polyliner, for 5021/5022/5023/5031 | 53.0 × 26.7 × 42.0cm | N/A | BRN | 6 |
| 6977 | Cloth/Straw Bag, for 5021/5022/5023 | 83.8 × 26.7 × 42.9cm | N/A | BRN | 6 |
| 6979 | Large-capacity Eight-compartment Bag, for 5021/5022/5023 | 98.5 × 78.0cm | N/A | BRN | 6 |
| 4831 | Pneumatic Caster Kit | Dia: 20cm | N/A | N/A | 1 |

GRANDMAID® COMPACT HOUSEKEEPING CARTS



PRODUCT FEATURES:

1. A complete system solution for housekeeping in hotels.
2. Durable molded construction with smooth surfaces, easy to clean.
3. 20cm (5051 casters 18cm) non-marking casters allow for easy maneuverability.
4. User friendly handles are easy to grip and help to maneuver the cart.
5. Bumpers available at four corners to protect walls and equipment.
6. 5051 double shelf linen cabinet increases linen storage volume.
7. Compatible with narrow passages.



5031



5051



Innovative interface fastens buckets Svelte® Container Buckets increasing space

| Model | Description | Dimensions | Capacity | Color | Pack |
|-------|--------------------------------------|------------------------|----------|-----------|------|
| 5031 | GRANDMAID® Compact Housekeeping Cart | 124.0 x 55.9 x 123.0cm | N/A | BLA, PLAT | 1 |
| 5051 | GRANDMAID® Cruise Housekeeping Cart | 102.4 x 51.0 x 109.0cm | N/A | BLA, PLAT | 1 |



ACCESSORIES



5037



5052



5033



5038



5054



6968



6969



6970



5025



5036

| Model | Description | Dimensions | Capacity | Color | Pack |
|-------|---|----------------------|----------|-----------|------|
| 1213 | SVELTE® Container for 5031 | 57.0 × 27.2 × 75.6cm | 87L | BRN | 4 |
| 1215 | SVELTE® Container for 5051 | 49.9 × 24.9 × 63.0cm | 46L | BRN | 4 |
| 1645 | SVELTE® Connect Valve Style Lid for 5031 | 54.8 × 32.5 × 4.0cm | N/A | BLA | 4 |
| 5025 | Under Deck Shelf Kit for 5021/5022/5023/5031 | 60.0 × 53.3 × 17.7cm | N/A | BLA, PLAT | 1 |
| 5033 | Storage Accessory (Set of 3) for 5031 | 48.3 × 21.2 × 12.4cm | N/A | BLA, PLAT | 1 |
| 5035 | Locking Door Kit for 5031 | 82.4 × 44.8 × 4.5cm | N/A | BLA, BRN | 1 |
| 5036 | Cleaning Tool Stack for 5031 | 30.6 × 10.9 × 9.0cm | N/A | BLA | 2 |
| 5037 | Hook Kit (Set of 4 - RED, YEL, BLUE, GRN) for 5031/5051 | 6.9 × 4.7 × 5.0cm | N/A | N/A | 1 |
| 5038 | Tops Work with 1213 | 53.3 × 32.6 × 2.8cm | N/A | BLA, PLAT | 2 |
| 5052 | Locking Door Kit for 5051 | 68.0 × 35.8 × 1.6cm | N/A | BLA, BRN | 1 |
| 5053 | Under Deck Shelf Kit for 5051 | 58.0 × 51.0 × 17.2cm | N/A | BLA, PLAT | 1 |
| 5054 | Vinyl Bag for 5051 | 43.0 × 26.5 × 74.0cm | N/A | BRN | 2 |
| 5055 | Tops Work with 1215 | 45.0 × 25.5 × 1.2cm | N/A | BLA | 2 |
| 6968 | Canvas Linen Accessory Bag for 5031 | 79.0 × 26.7 × 42.7cm | N/A | BRN | 6 |
| 6969 | Fabric Mesh Linen Bag for 5031 | 79.0 × 26.7 × 42.7cm | N/A | BRN | 6 |
| 6970 | Vinyl Bag for 5031 | 79.0 × 26.7 × 42.7cm | N/A | BRN | 6 |

* Accessories 5027/5028/5029/5030/5039/5056/5057/5067/5077/4851/5024/6954/6975/6976/4831 on page 69 are also suitable for use with Compact Housekeeping Carts (5031).

PINNACLE® INTELLIGENT HOUSEKEEPING CART

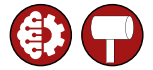

PRODUCT FEATURES:

1. Powered housekeeping cart improves overall efficiency.
2. Intelligent control system, easy-to-operate.
3. High performance battery can power a loaded cart for up to 1 to 2 weeks.
4. Durable molded construction with smooth surfaces, easy to clean.
5. Ergonomic handles are easy to grip and help to maneuver the cart.
6. Bumpers available at four corners to protect walls and equipment.
7. Two types of top shelf are available. The top shelf fitted with dividers is a great place for organizing tools.



5061



Innovative interface fastens buckets Svelte® Container Buckets increasing space



Top shelf fitted with dividers is a great place for organizing tools



5062



5063



5064

INTELLIGENT CONTROL SYSTEM

When an operator pushes a cart, the cart will recognize the direction of this force and will move forward automatically. Conversely when an operator pulls the cart, the cart will also recognize the direction of this force and will move backward automatically.

Once the cart starts to move, the operator simply needs to hold the handle with both hands to control the direction of the cart. No strength is needed to push or pull the cart.

| Model | Description | Dimensions | Capacity | Color | Pack |
|-------|---|------------------------|----------|-------|------|
| 5061 | PINNACLE® Intelligent Housekeeping Cart | 152.4 × 57.7 × 117.8cm | N/A | BLA | 1 |
| 5062 | PINNACLE® Intelligent Housekeeping Cart | 152.4 × 57.7 × 122.8cm | N/A | BLA | 1 |
| 5063 | PINNACLE® Intelligent Housekeeping Cart | 126.2 × 57.7 × 117.8cm | N/A | BLA | 1 |
| 5064 | PINNACLE® Intelligent Housekeeping Cart | 126.2 × 57.7 × 122.8cm | N/A | BLA | 1 |
| 5071 | PINNACLE® Intelligent Housekeeping Cart with Built-In Divider | 152.4 × 57.7 × 117.8cm | N/A | BLA | 1 |
| 5072 | PINNACLE® Intelligent Housekeeping Cart with Built-In Divider | 152.4 × 57.7 × 122.8cm | N/A | BLA | 1 |
| 5073 | PINNACLE® Intelligent Housekeeping Cart with Built-In Divider | 126.2 × 57.7 × 117.8cm | N/A | BLA | 1 |
| 5074 | PINNACLE® Intelligent Housekeeping Cart with Built-In Divider | 126.2 × 57.7 × 122.8cm | N/A | BLA | 1 |

ACCESSORIES



5067



5037



4851



1645



6968



6969



6976



6975



1211



1213



5036

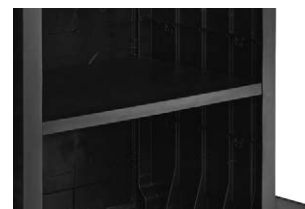

5065

| Model | Description | Dimensions | Capacity | Color | Pack |
|---|---|----------------------|----------|-----------|------|
| ACCESSORIES TO SUIT ALL PINNACLE® INTELLIGENT HOUSEKEEPING CARTS | | | | | |
| 5065 | Adjustable Shelf Kit | 76.1 × 47.2 × 5.5cm | N/A | BLA | 1 |
| 5067 | Safety Shield | 80.3 × 52.8 × 36.6cm | N/A | BLA, PLAT | 1 |
| 5036 | Cleaning Tool Stack | 30.6 × 10.9 × 9.0cm | N/A | BLA | 2 |
| 5037 | Hook Kit (Set of 4 - RED, YEL, BLUE, GRN) | 6.9 × 4.7 × 5.0cm | N/A | N/A | 1 |
| 4851 | Utility Sliding Drawer | 65.7 × 43.0 × 8.2cm | N/A | BLA, BRN | 1 |
| 6975 | Fabric 9-pocket Organizer | 71.1 × 50.2 × 3.8cm | N/A | BRN | 6 |
| 6976 | Short Polyliner | 53.0 × 26.7 × 4.2cm | N/A | BRN | 6 |
| 5075 | Battery Charger | 14.0 × 6.0 × 3.5cm | N/A | BLA | 1 |
| 5076 | Battery Pack | 23.0 × 5.5 × 15.7cm | N/A | BLA | 1 |
| ACCESSORIES TO SUIT CARTS 5061 / 5063 / 5071 / 5073 | | | | | |
| 5066 | Locking Door Kit for 5061 / 5063 / 5071 / 5073 | 87.0 × 74.9 × 2.3cm | N/A | BLA | 1 |
| 5068 | Vinyl Bag for 5061 / 5063 / 5071 / 5073 | 83.8 × 26.7 × 4.2cm | N/A | BLA | 6 |
| 6968 | Canvas Linen Accessory Bag for 5061/5063/5071/5073 | 79.0 × 26.7 × 4.2cm | N/A | BRN | 6 |
| 6969 | Fabric Mesh Linen Bag for 5061/5063/5071/5073 | 79.0 × 26.7 × 4.2cm | N/A | BRN | 6 |
| ACCESSORIES TO SUIT CARTS 5062 / 5064 / 5072 / 5074 | | | | | |
| 5069 | Vinyl Bag for 5062 / 5064 / 5072 / 5074 | 79.0 × 26.7 × 4.2cm | N/A | BLA | 6 |
| 5070 | Locking Door Kit for 5062 / 5064 / 5072 / 5074 | 87.0 × 69.9 × 2.3cm | N/A | BLA | 1 |
| 6973 | Canvas Linen Accessory Bag for 5062 / 5064 / 5072 / 5074 | 83.8 × 26.7 × 4.2cm | N/A | BRN | 6 |
| 6974 | Fabric Mesh Linen Bag for 5062 / 5064 / 5072 / 5074 | 83.8 × 26.7 × 4.2cm | N/A | BRN | 6 |
| 6977 | Cloth/Straw Bag, for 5062 / 5064 / 5072 / 5074 | 83.8 × 26.7 × 4.2cm | N/A | BRN | 6 |
| 6979 | Large-capacity Eight-compartment Bag, for 5062 / 5064 / 5072 / 5074 | 98.5 × 78.0cm | N/A | BRN | 6 |
| ACCESSORIES TO SUIT CARTS 5063 / 5064 / 5073 / 5074 | | | | | |
| 1211 | SVELTE® Container | 57.0 × 27.2 × 63.2cm | 60L | BRN | 4 |
| 1213 | SVELTE® Container | 57.0 × 27.2 × 75.6cm | 87L | BRN | 4 |
| 1645 | SVELTE® Connect Valve Style Lid for 5063 / 5064 / 5073 / 5074 | 54.8 × 32.5 × 4.0cm | N/A | BLA | 4 |

CLEABOX® ROOM SERVICE CARTS

PRODUCT FEATURES:

1. A fast-moving room service cart for room cleaning and environmental maintenance.
2. The surface coating is waterproof and oil proof to ensuring a professional appearance.
3. High-performance materials and high-strength structure ensure daily normal use.
4. Support plate with heavy-duty structure can prolong service life.
5. Adjustable partition plates allow you to orderly and neatly place daily necessities.
6. The side tool bag can offers a secure position for the telescopic rod (6411).
7. Waterproof side bag for the toilet brush to keep the floor clean and tidy.



5082



5081



Repels water, oil, and stains, **Teflon® fabric protector** helps maintain and protect from rigorous daily use



Reinforced rubberized kick plate for increased durability and reduced wear and tear



Water proof side bag for the toilet brush to keep the floor clean and tidy



5084

Tool basket is ideal for storing cleaning tools and cleaning materials.
Lined Bags help to extend product life.

| Model | Description | Dimensions | Capacity | Color | Pack |
|-------------|----------------------------|----------------------|----------|-------|------|
| 5081 | CLEABOX® Room Service Cart | 41.9 × 36.5 × 63.5cm | N/A | BRN | 1 |
| 5082 | CLEABOX® Room Service Cart | 41.9 × 36.5 × 53.5cm | N/A | BRN | 1 |
| 5083 | CLEABOX® Room Service Cart | 41.9 × 36.5 × 43.5cm | N/A | BRN | 1 |
| ACCESSORIES | | | | | |
| 5084 | Tool Basket | 35.5 × 28.0 × 14.0cm | N/A | BRN | 1 |
| 5085 | Lined Bag for 5081 | 38.0 × 32.5 × 55.0cm | N/A | BLA | 1 |
| 5086 | Lined Bag for 5082 | 38.0 × 32.5 × 45.0cm | N/A | BLA | 1 |
| 5087 | Lined Bag for 5083 | 38.0 × 32.5 × 35.0cm | N/A | BLA | 1 |



GRANDMAID® CLEANING CARTS



PRODUCT FEATURES:

1. An ideal solution for collecting trash and transporting cleaning tools to effectively increase cleaning efficiency.
2. Smooth surface for easy cleaning.
3. Zipped waste bags assist in emptying of waste.
4. 20cm non-marking wheels and 10cm non-marking casters enhance maneuverability.
5. A complete system solution with integrated holders for various tools to cater for your cleaning.



For storage of dustpan with a short handle



Holder for screwdrivers, pliers and other tools



Elastic clamp can hold broom and mop handles with diameter 2.2 to 2.9cm



Holder for safety signs

| Model | Description | Dimensions | Capacity | Color | Pack |
|-------|--------------------------|-----------------------|----------|-----------|------|
| 5011 | GRANDMAID® Cleaning Cart | 116.8 × 55.2 × 97.5cm | N/A | BLA, PLAT | 1 |



Zipped waste bags assist in emptying of waste



Four accessory bags on both sides of the bag for holding of cleaning tools



Suitable for cleaning storage, e.g. tissue paper and detergent; drawers can be opened from two directions

ACCESSORIES



The **cover** (5012) helps contain odors and prevents flies from entering



Spray bottle stack (5013) is suitable for spray bottle storage



Storage cabinet (5014) can carry sharp cleaning tools, such as scraper, blade etc., effectively reducing the risk of injury



Lockable top cover (5015) safely manage detergent and other chemicals



Garbage classification fixed frame (5016), convenient for garbage classification management



Small garbage bag (5018), convenient for garbage classification management



Square bucket (5264) enables sorting of cleaning tools



Cleaning bucket (5267) classifies cleaning items and reduces the risk of cross infection



Lockable doors (5019) keeps cleaning supplies concealed



Drawers (5266) allows convenient and safe storage of cleaning supplies



Cleaning tool brackets (5017) offer storage space for mops and other cleaning tools



Tool boxes (5268) with built-in compartments offer exceptional storage space for various cleaning supplies



| Model | Description | Dimensions | Capacity | Color | Pack |
|-------|------------------------------------|----------------------|----------|---------------------|------|
| 5010 | Clip for Handle | 7.6 × 11.5 × 4.4cm | N/A | BLA, PLAT | 6 |
| 5012 | Trash Bag Cover, for 5011 | 46.8 × 32.3 × 3.9cm | N/A | BLA, PLAT | 2 |
| 5013 | Spray Bottle Stack | 42.5 × 12.0 × 6.5cm | N/A | BLA | 2 |
| 5014 | Storage Cover, for 5011 | 46.8 × 32.3 × 4.4cm | N/A | BLA, PLAT | 1 |
| 5015 | Lockable Top Cover, for 5011 | 46.5 × 35.0 × 41.0cm | N/A | BLA, PLAT | 1 |
| 5016 | Garbage Classification Fixed Frame | 45.4 × 28.1 × 4.1cm | N/A | BLA | 1 |
| 5018 | Small Garbage Bag | 43.0 × 62.0 × 9.0cm | N/A | BLUE | 6 |
| 5264 | Quadrate Bucket | 35.8 × 21.8 × 20.5cm | N/A | YEL, BLA | 6 |
| 5267 | Cleaning Bucket (4 colors per set) | 21.3 × 17.7 × 21.5cm | N/A | N/A | 1 |
| 6971 | Zippered Trash Bag, for 5011 | 43.8 × 26.7 × 77.5cm | N/A | YEL | 2 |
| 6978 | Polyliner with Side Bag, for 5011 | 43.8 × 26.7 × 77.5cm | N/A | BLUE, YEL, GRN, RED | 2 |
| 5019 | Locking Door Kit for 5011 | 54.0 × 39.7 × 29.4cm | N/A | YEL, BLA | 1 |
| 5266 | Drawer | 48.5 × 25.7 × 26.0cm | N/A | YEL, BLA | 2 |
| 5017 | Cleaning Tool Bracket | 27.6 × 12.9 × 12.0cm | N/A | BLA | 6 |
| 5268 | Tool Box | 57.6 × 36.5 × 28.9cm | N/A | YEL, GRAY | 1 |

CLEANING CART COMBINATION



SVELTE® RIM CADDIES & DOLLIES



PRODUCT FEATURES:

1. The combined cleaning system is composed of Svelte® trolley, Svelte® trash can and Svelte® tool assembly rack, which is convenient and efficient for collecting garbage and carrying cleaning tools.
2. The slim rectangle shape is space efficient and suitable for tight spaces.
3. Convenient for sorting collection.
4. Svelte® Dollies (1825) offer sturdy structural foam construction that won't rust, dent, chip, or peel; 7.5cm non-marking casters reduce the post-job clean-up.
5. When used with the connection device (1826), the two trolleys can be firmly connected together to improve working efficiency.



1824/1213/1825



1825



Rim Caddies (1824) holds a safety sign



Rim Caddies (1824) can secure two garbage bags on the rim for efficient classification collection



Rim Caddies (1824) elastic clamp can hold broom and mop handles with diameter 2.2 to 2.9cm



Dolly Connectors (1826) connects several dollies together for collection and transportation purposes

| Model | Description | Dimensions | Capacity | Color | Pack |
|-------|--------------------------------------|----------------------|----------|------------|------|
| 1213 | SVELTE® Container | 57.0 × 27.2 × 75.6cm | 87L | BLA, LGRAY | 4 |
| 1220 | SVELTE® Container | 51.3 × 27.2 × 75.6cm | 87L | BLA, LGRAY | 4 |
| 1814 | SVELTE® Dolly for 1211/1213 | 51.6 × 29.0 × 26.0cm | N/A | BLA | 2 |
| 1824 | SVELTE® Rim Caddy for 1211/1213/1220 | 74.6 × 37.6 × 11.9cm | N/A | YEL, BLA | 1 |
| 1825 | SVELTE® Dolly for 1211/1213/1220 | 63.5 × 30.0 × 24.6cm | N/A | BLA | 2 |
| 1826 | SVELTE® Connector for 1825 | 15.9 × 10.9 × 11.4cm | N/A | BLA | 1 |

SVELTE® CADDY BAGS

PRODUCT FEATURES:

1. Nylon reinforced vinyl bags are durable and easy to keep clean.
2. Includes pockets of various sizes to place cleaning supplies.
3. Used together with Svelte® trash can and Svelte® trolley (1814, 1825), it is convenient and efficient to collect garbage and carry cleaning tools.

SVELTE® HOOKS

PRODUCT FEATURES:

1. Tightening lock on the brim of Rim Caddies (1824).
2. Suitable for hanging all kinds of cleaning tools.
3. Made of sturdy, durable plastics.



1827



1828/1213/1825

| Model | Description | Dimensions | Capacity | Color | Pack |
|-------|----------------------------|-------------------|----------|----------|------|
| 1827 | SVELTE® Hook for 1824 | 4.3 × 3.6 × 4.2cm | N/A | YEL, BLA | 4 |
| 1828 | SVELTE® Caddy Bag for 1213 | 50.0 × 48.0cm | N/A | YEL, BLA | 2 |

THOR® RIM CADDIES

PRODUCT FEATURES:

1. Snaps securely onto rim of 166L round container (1014).
2. Built-in straps allow for easy polyliner attachment.
3. User-friendly handle improves maneuverability and minimizes contact with refuse.
4. Provides storage for spray bottles, safety signs, cleaning sponges, lobby dust pan, brushes, liners, gloves etc.
5. Made of tough and durable plastic.
6. Smooth surfaces allow for easy cleaning.



1821



1014/1821/1811



| Model | Description | Dimensions | Capacity | Color | Pack |
|-------|--|----------------------|----------|-------|------|
| 1014 | THOR® Round Container | 61.0 × 80.0cm | 166L | GRAY | 4 |
| 1811 | THOR® Dolly for 1010/1012/1013/1014/1015 | 46.4 × 16.8cm | N/A | BLA | 2 |
| 1821 | THOR® Rim Caddy for 1014 | 88.2 × 70.3 × 17.0cm | N/A | YEL | 1 |

THOR® CADDY BAGS

PRODUCT FEATURES:

1. Nylon reinforced vinyl bags are durable and easy to keep clean.
2. Pockets of various sizes for placing cleaning supplies.



1014/1831/1811

| Model | Description | Dimensions | Capacity | Color | Pack |
|-------|-------------------------------|-------------------|----------|-------|------|
| 1831 | THOR® Caddy Bag for 1013/1014 | Dia 50.8 × 52.1cm | N/A | YEL | 6 |

CARRY CADDIES

PRODUCT FEATURES:

1. Perfect for carrying tools or cleaning supplies.
2. Securely attaches to the brim of the 121L (1013) Round Container.
3. User-friendly handle fits your hand and provides a comfortable grip.
4. Securely holds Spray Bottles (6947) and other common cleaning tools.
5. Allows for stable stacking to save space.
6. Rounded corners ensure safety and prevent injury.



1823

| Model | Description | Dimensions | Capacity | Color | Pack |
|-------|-------------|----------------------|----------|-------|------|
| 1823 | Carry Caddy | 37.5 × 32.0 × 18.0cm | N/A | BLA | 4 |

SIGNBOARD HOOKS

PRODUCT FEATURES:

1. An ideal solution for hanging Floor Safety Signs (7114, 7161, 7162, 7163).
2. Tightening lock on the brim of 121L Round Container (1013).
3. Made of sturdy, durable plastics.



1822

| Model | Description | Dimensions | Capacity | Color | Pack |
|-------|----------------|---------------------|----------|-------|------|
| 1822 | Signboard Hook | 15.3 × 10.0 × 6.0cm | N/A | BLA | 6 |



COLLAPSIBLE LINEN CARTS

PRODUCT FEATURES:

1. Suitable for collecting and transporting all kinds of guest room linen or waste.
2. Compact, collapsible frame reduces space by 73% to enable efficient storage and transport.
3. Durable, lightweight add ease control.
4. Non-marking swivel castors allow easy to control in narrow spaces, providing quiet operation and protecting floors from damage.
5. Corner bumpers available to protect walls and equipment
6. Durable powder-coated steel frame.
7. Sturdy and durable vinyl bag, easy to clean.
8. Specially designed trailer function can connect multiple carts together for efficient transportation.
9. Cover is sold separately.



Trailer function can connect multiple carts together for efficient transportation.

COVER

PRODUCT FEATURES:

1. High quality vinyl cover, easy to clean.
2. Built-in storage bag allows convenient storage of cleaning tools.
3. Zipper on the top provides easy access to the items inside without removing the cover.



| Model | Description | Dimensions | Capacity | Color | Pack |
|-------|---------------------------|----------------------|----------|-------|------|
| 5045 | Classification Linen Cart | 76.7 × 64.2 × 82.0cm | 200L | GRAY | 1 |
| 5046 | Classification Linen Cart | 94.2 × 64.2 × 82.0cm | 240L | GRAY | 1 |
| 5047 | Cloth/Straw Bag, for 5045 | 33.0 × 51.0 × 60.0cm | 100L | BLA | 2 |
| 5048 | Cloth/Straw Bag, for 5046 | 39.5 × 51.0 × 60.0cm | 120L | BLA | 2 |
| 5088 | Collapsible Linen Cart | 65.2 × 53.8 × 82.0cm | 120L | GRAY | 1 |
| 5089 | Collapsible Linen Cart | 76.7 × 64.2 × 82.0cm | 200L | GRAY | 1 |
| 5090 | Collapsible Linen Cart | 94.2 × 64.2 × 82.0cm | 240L | GRAY | 1 |
| 5091 | Cloth/Straw Bag, for 5088 | 52.0 × 40.0 × 60.0cm | 120L | BLA | 2 |
| 5092 | Cloth/Straw Bag, for 5089 | 67.0 × 51.0 × 60.0cm | 200L | BLA | 2 |
| 5093 | Cloth/Straw Bag, for 5090 | 80.2 × 51.0 × 60.0cm | 240L | BLA | 2 |
| 5094 | Cover for 5088 | 56.0 × 45.0 × 23.0cm | N/A | BLA | 2 |
| 5097 | Cover for 5045/5089 | 68.0 × 55.0 × 23.0cm | N/A | BLA | 2 |
| 5098 | Cover for 5046/5090 | 85.0 × 55.0 × 23.0cm | N/A | BLA | 2 |

CLEANING CART COMBINATION

X TYPE LINEN CARTS

PRODUCT FEATURES:

1. Fit for collecting all kinds of linen.
2. Durable, lightweight and easy to control.
3. High quality canvas bag with side straps for easy access.
4. Fold to save space and make storage and transportation easier.
5. 5095 and 5096 storage bags used with linen cart are convenient for carrying cleaning supplies. (Refer to image on next page.)



5041



5042

| Model | Description | Dimensions | Capacity | Color | Pack |
|-------|------------------------------------|-----------------------|----------|-------|------|
| 5041 | X Type Linen Cart | 70.5 × 63.5 × 87.6cm | 170L | GRAY | 1 |
| 5042 | X Type Linen Cart | 94.0 × 66.0 × 101.0cm | 340L | GRAY | 1 |
| 5043 | Cloth/Straw Bag for 5041 | 65.5 × 58.5 × 67.5cm | 170L | BRN | 2 |
| 5044 | Cloth/Straw Bag for 5042 | 84.0 × 58.5 × 86.0cm | 340L | BRN | 2 |
| 5095 | Fabric Hanging Organizers for 5041 | 64.0 × 68.5 × 3.0cm | N/A | BRN | 2 |
| 5096 | Fabric Hanging Organizers for 5042 | 80.5 × 85.0 × 3.0cm | N/A | BRN | 2 |

Combine the accessories with your **THOR**® or **SVELTE**® CONTAINERS to turn the container into a mini cleaning cart that suit your need.





MOPPING SYSTEMS



ALL-IN-ONE BUCKETS

PRODUCT FEATURES:

1. An easy-to-maneuver mopping system, compact and powerful, carries all your needs for wet mopping and light cleaning.
2. Durable wringer designed for wringing over 25,000 times.
3. Ergonomically designed handle fit your hands and height, and reduce the need for bending.
4. Non-marking all-plastic wheels reduce post-job clean-up.
5. A discharge valve is available at the bottom of bucket to allow for emptying of dirty water without lifting.
6. A caddy is available to carry small cleaning tools which can be removed when not needed.
7. Build-in hook to hang Safety Signs.
8. Multi colors are available to reduce cross-contamination between work areas.



Non-marking all-plastic wheels reduce post-job clean-up



A **caddy** is available to carry small cleaning tools which can be removed when not needed



Ergonomically designed **handle** fit your hands and height, and reduce the need for bending



Comfortable **hand grip** assists in lifting and emptying dirty water



A **discharge valve** is available at the bottom of bucket to allow for emptying of dirty water without lifting



Has **capacity to carry additional caddy (5262)** at the rear for cleaning tools

| Model | Description | Dimensions | Capacity | Color | Pack |
|-------|-------------------|----------------------|----------|---------------------|------|
| 5210 | Wringer for 5211 | 34.1 × 44.2 × 49.0cm | N/A | BLUE, GRN, RED, YEL | 1 |
| 5211 | All-in-one Bucket | 67.3 × 38.1 × 88.4cm | 25L | BLUE, GRN, RED, YEL | 1 |
| 5262 | Bucket for 5211 | 15.2 × 20.3 × 30.5cm | 3L | BLUE, GRN, RED, YEL | 2 |

GRANDMAID® SIDE PRESS COMBOS

PRODUCT FEATURES:

1. The anti-splash mop bucket and wringer system reduces splashing providing a safer environment, cleaner floors, and improved productivity.
2. High-efficiency wringer, wrings mop with 18% less effort.
3. Lasts 58 times longer than generic wringers.
4. Made of premium tubular steel and structural web molded plastic to ensure higher durability and toughness.
5. Ergonomically designed handle fit your hands and height, and reduce the need for bending.
6. Non-marking all-plastic wheels reduce post-job clean-up.
7. Optional dirty water bucket separates dirty water from the cleaning solution.



5226



Comfortable **hand grip** assists in lifting and emptying dirty water



Ergonomically designed **handle** fit your hands and height, and reduce the need for bending



Dirty Water Bucket

1. Keeps the dirty water from clean water.
2. Maintains the cleaning capability of cleanser.
3. Minimizes the consumption of water and chemical.
4. Brings you cleaner floor.
5. Divides the liquid to reduce the bucket weight for lifting and assist in emptying.



7.5cm non-marking **all-plastic wheel**



5221



5222



5225



5224

| Model | Description | Dimensions | Capacity | Color | Pack |
|-------|--|----------------------|----------|--------------------------|------|
| 5221 | GRANDMAID® Bucket with Kits | 63.3 × 39.2 × 42.5cm | 33L | BLUE, GRN, RED, YEL, BRN | 4 |
| 5222 | GRANDMAID® Side Press Wringer for 5221 | 56.0 × 40.5 × 95.0cm | N/A | BLUE, GRN, RED, YEL, BRN | 2 |
| 5223 | GRANDMAID® Side Press Combo | 63.3 × 39.2 × 94.5cm | 33L | YEL, BRN | 1 |
| 5224 | GRANDMAID® Bucket with Kits | 51.1 × 40.6 × 44.2cm | 33L | BLUE, GRN, RED, YEL, BRN | 4 |
| 5225 | GRANDMAID® Side Press Wringer for 5224 | 33.0 × 33.0 × 68.6cm | N/A | BLUE, GRN, RED, YEL, BRN | 2 |
| 5226 | GRANDMAID® Side Press Combo | 51.5 × 40.6 × 92.7cm | 33L | BLUE, GRN, RED, YEL, BRN | 1 |
| 5229 | GRANDMAID® Bucket with Kits | 49.5 × 37.2 × 42.4cm | 25L | YEL | 4 |
| 5261 | Dirty Water Bucket for 5221/5223 | 56.0 × 40.5 × 29.5cm | 17L | RED, YEL | 2 |
| 5263 | Dirty Water Bucket for 5224/5226/5228 | 35.8 × 25.1 × 35.8cm | 17L | RED, YEL | 2 |
| 5300 | GRANDMAID® Side Press Combo | 50.0 × 37.2 × 90.0cm | 25L | YEL | 1 |

GRANDMAID® DOWN PRESS COMBOS



PRODUCT FEATURES:

1. The anti-splash mop bucket and wringer system reduces splashing providing a safer environment, cleaner floors, and improved productivity.
2. High-efficiency wringer, wrings mop with 18% less effort.
3. Lasts 58 times longer than generic wringers.
4. Made of premium tubular steel and structural web molded plastic to ensure higher durability and toughness.
5. Ergonomically designed handle fit your hands and height, and reduce the need for bending.
6. Non-marking all-plastic wheels reduce post-job clean-up.
7. Optional dirty water bucket separates dirty water from the cleaning solution.



5228



Ergonomically designed **handle** fit your hands and height, and reduce the need for bending



Dirty Water Bucket

1. Keeps the dirty water from clean water.
2. Maintains the cleaning capability of cleanser.
3. Minimizes the consumption of water and chemical.
4. Brings you cleaner floor.
5. Divides the liquid to reduce the bucket weight for lifting and assist in emptying.



7.5cm non-marking all-plastic wheel



5224



5227

WET MOPS GUIDE

The down press wringer is suitable for mops with headband length less than 10cm, such as 6064/6072/6073.

| Model | Description | Dimensions | Capacity | Color | Pack |
|-------|---------------------------------------|----------------------|----------|--------------------------|------|
| 5224 | GRANDMAID® Bucket with Kits | 51.1 × 40.6 × 44.2cm | 33L | BLUE, GRN, RED, YEL, BRN | 4 |
| 5227 | GRANDMAID® Down Press Wringer | 34.3 × 33.5 × 68.6cm | N/A | BLUE, GRN, RED, YEL, BRN | 2 |
| 5228 | GRANDMAID® Down Press Combo | 51.5 × 40.6 × 92.7cm | 33L | YEL, BRN | 1 |
| 5229 | GRANDMAID® Bucket with Kits | 49.5 × 37.2 × 42.4cm | 25L | YEL | 4 |
| 5263 | Dirty Water Bucket for 5224/5226/5228 | 35.8 × 25.1 × 35.8cm | 17L | RED, YEL | 2 |
| 5301 | GRANDMAID® Down Press Combo | 50.0 × 37.2 × 90.0cm | 25L | YEL | 1 |

GRANDMAID® DUAL WATER MOPPING COMBOS

PRODUCT FEATURES:

1. The anti-splash mop bucket and wringer system reduces splashing providing a safer environment, cleaner floors, and improved productivity.
2. High-efficiency wringer, wrings mop with 18% less effort.
3. Lasts 58 times longer than generic wringers.
4. Made of premium tubular steel and structural web molded plastic to ensure higher durability and toughness.
5. Ergonomically designed handle fit your hands and height, and reduce the need for bending.
6. Non-marking all-plastic wheels reduce post-job clean-up.
7. A bucket included to separate clean and dirty water.
8. Double luxury model can improve the image and increase the stability.



5311

5312

| Model | Description | Dimensions | Capacity | Color | Pack |
|-------|--|----------------------|----------|-------|------|
| 5311 | GRANDMAID® Dual Water Side Press Combo | 56.9 × 41.9 × 98.0cm | 33L | YEL | 1 |
| 5312 | GRANDMAID® Dual Water Down Press Combo | 56.9 × 41.9 × 98.0cm | 33L | YEL | 1 |

GRANDMAID® MOPPING SYSTEM ACCESSORIES

PRODUCT FEATURES:

1. Various accessories available to solve problems and reduce cost.
2. Complete mop solutions to improve efficiency.



5310

5224

5263

5225

5227

| Model | Description | Dimensions | Capacity | Color | Pack |
|------------------------------|--|----------------------|----------|--------------------------|------|
| GRANDMAID® BUCKETS WITH KITS | | | | | |
| 5221 | GRANDMAID® Bucket with Kits | 63.3 × 39.2 × 42.5cm | 33L | BLUE, GRN, RED, YEL, BRN | 4 |
| 5224 | GRANDMAID® Bucket with Kits | 51.1 × 40.6 × 44.2cm | 33L | BLUE, GRN, RED, YEL, BRN | 4 |
| 5229 | GRANDMAID® Bucket with Kits | 49.5 × 37.2 × 42.4cm | 25L | YEL | 4 |
| GRANDMAID® WRINGERS | | | | | |
| 5222 | GRANDMAID® Side Press Wringer for 5221 | 56.0 × 40.5 × 95.0cm | N/A | BLUE, GRN, RED, YEL, BRN | 2 |
| 5225 | GRANDMAID® Side Press Wringer for 5224 | 33.0 × 33.0 × 68.6cm | N/A | BLUE, GRN, RED, YEL, BRN | 2 |
| 5227 | GRANDMAID® Down Press Wringer | 34.3 × 33.5 × 68.6cm | N/A | BLUE, GRN, RED, YEL, BRN | 2 |
| ACCESSORIES | | | | | |
| 5261 | Dirty Water Bucket for 5221/5223 | 56.0 × 40.5 × 29.5cm | 17L | RED, YEL | 2 |
| 5263 | Dirty Water Bucket for 5224/5226/5228 | 35.8 × 25.1 × 35.8cm | 17L | RED, YEL | 2 |
| 5310 | Quiet Caster Dolly | 51.8 × 41.5 × 16.8cm | N/A | BLA | 1 |

PEDAL MOP WRINGERS

PRODUCT FEATURES:

1. Heavy-duty iron bucket with reinforced base.
2. Sturdy construction from heavy-duty galvanized sheets for an extended service life.
3. Comes with base casters for easy mobility and maneuverability.
4. No need for bending or hand-wringing.
5. Copper roller is durable and rust resistant.



Copper roller is durable and rust resistant



Comes with base casters for easy mobility and maneuverability



5281

| Model | Description | Dimensions | Capacity | Color | Pack |
|-------|-------------------|----------------------|----------|-------|------|
| 5281 | Pedal Mop Wringer | 47.5 × 28.5 × 37.0cm | 15L | MSILV | 1 |

PAIL AND MOP STRAINER COMBINATIONS

PRODUCT FEATURES:

1. Lightweight and easy to clean, helps to improve operator productivity.
2. Pail holds up to 14L. Strainer fits for a small mop.
3. Comfortable plastic handle for lifting the pail.
4. Durable plastic construction has smooth, easy-to-clean surface.
5. Pails and mop strainers nest and stack for convenient transport and storage between jobs.
6. Bottom hand-holds assist in emptying.



5231



5271

| Model | Description | Dimensions | Capacity | Color | Pack |
|-------|-----------------------------------|----------------------|----------|-------|------|
| 5231 | Pail and Mop Strainer Combination | 43.0 × 31.2 × 31.6cm | 14L | GRAY | 6 |
| 5271 | Cotton Mop and Handle Combination | 150.0cm | N/A | WHT | 4 |
| 5272 | Replacement Mop for 5271 | 20.0cm | N/A | WHT | 12 |

DOUBLE PAILS

PRODUCT FEATURES:

1. Strong and durable.
2. Includes graduations for accurate measuring.
3. Comfortable plastic handle for easy lifting of the pail.
4. Separates the clean water from the dirty water.
5. Allows for stable stacking to save space.



5241



5242

| Model | Description | Dimensions | Capacity | Color | Pack |
|-------|--------------|----------------------|----------|-------|------|
| 5241 | Double Pails | 38.2 x 35.4 x 25.2cm | 16L | GRAY | 6 |
| 5242 | Double Pails | 45.6 x 36.8 x 27.0cm | 18L | GRAY | 6 |

STEEL SPONGE MOPS

PRODUCT FEATURES:

1. Front-pull lever on the mop handle allows for squeeze-action wringing.
2. Mop head is replaceable.



5273



5275

| Model | Description | Dimensions | Capacity | Color | Pack |
|-------|--------------------------------------|-----------------------|----------|-------|------|
| 5273 | Steel Sponge Mop with Cellulose Head | 27.0 x 12.5 x 140.0cm | N/A | BLUE | 6 |
| 5274 | Steel Cellulose Replacement Head | 27.0cm | N/A | YEL | 12 |
| 5275 | PVA Sponge Mop | 27.0 x 6.5 x 130.0cm | N/A | BLA | 4 |
| 5276 | PVA Sponge Mop Refill | 27.0cm | N/A | N/A | 12 |



ROUND BUCKETS



PRODUCT FEATURES:

1. Heavy-duty thick wall construction ensures durability and toughness.
2. Graduations on round shape ensure accurate measuring and increase efficiency.
3. Easy to lift the bucket with a comfortable plastic handle.
4. Bottom hand-hold assists in emptying.
5. Allows for stable stacking to save space.



5251



5252



5253



5254

| Model | Description | Dimensions | Capacity | Color | Pack |
|-------|--------------|---------------|----------|--------------------------------|------|
| 5251 | Round Bucket | 26.7 × 26.0cm | 10L | BLUE, GRAY, GRN, RED, YEL, WHT | 12 |
| 5252 | Round Bucket | 30.5 × 28.6cm | 13L | BLUE, GRAY, GRN, RED, YEL, WHT | 6 |
| 5253 | Round Bucket | 26.0 × 24.0cm | 9L | BLUE, GRAY, GRN, RED, YEL | 12 |
| 5254 | Round Bucket | 28.0 × 26.0cm | 12L | BLUE, GRAY, GRN, RED, YEL | 6 |

QUADRATE BUCKET



PRODUCT FEATURES:

1. Strong and durable.
2. Works with Cleaning Cart (5011) to enhance cleaning efficiency.
3. User-friendly handle provides a comfortable grip.
4. Allows for stable stacking to save space.
5. Quadrate Bucket (5264) can store Spray Bottle (6947) and classified storage cleaning accessories.



5264



5265

| Model | Description | Dimensions | Capacity | Color | Pack |
|-------|-----------------|----------------------|----------|--------------------------|------|
| 5264 | Quadrate Bucket | 35.8 × 21.8 × 20.5cm | 9.5L | BLUE, GRN, RED, YEL, BLA | 6 |
| 5265 | Quadrate Bucket | 21.3 × 17.7 × 21.5cm | 4.7L | BLUE, GRN, RED, YEL | 6 |



WET MOPS



WET MOP SELECTION GUIDE

WET MOPS

Various criteria can apply when selecting the correct wet mop. Please follow the selection guide given here to select the best wet mop for your floor maintenance.

Mops for General Cleaning

Mops with excellent absorbency, easy water release and high durability are preferred. If conditions permit, washable mops are your best choice. Synthetic yarn, rayon and blend mops with looped-end and tailband are most washable and provide an optimized performance.

Finish Mops

Mops with excellent absorbency, and easy water release are preferred. In addition, looped-end and tailbanded mops cover more floor area per stroke and reduce streaking.

What is more important for you?

Launderability and Durability:

Launderability is the number of times a mop can be washed and dried before it is worn out. Durability is indicated by the length of time that passes before it is necessary to replace a worn mop. Mops made of microfiber, rayon and blend have the highest durability.



Microfiber Synthetic Blend Rayon

Absorbencies:

Absorbency means the capability to retain liquid. Higher absorbency means a shorter time to dry the floor, higher working efficiency and safer operation. Microfiber, rayon and cotton mops offer the best absorbency.



Microfiber Rayon Cotton Blend

Water-release Performance:

Water-release performance means the mop's capacity to release water on to the floor or during wringing. Stronger water-release performance means a shorter time is needed to wring the mop and effectively release the cleanser onto the floor. Microfiber, rayon and synthetic fiber mops have the strongest water-release capability.



Microfiber Rayon Synthetic Blend

Cleaning Performance:

It indicates the capability to remove dust and dirt from the floor.



Microfiber Rayon Synthetic Blend



WET MOP SELECTION GUIDE

| Category | Laundrying | Vinyl Tile, Laminate Flooring and Smooth Ceramic Tile Flooring | Floor Tiles, Terrazzo, Pavement Slab and Square Stone Slab | Rubber, Hardwood, Smooth Concrete |
|---------------------------|---|---|---|---|
| Health Care | Premium Washable Mops Standard Washable Mop Unwashable Disposable Mop | Microfiber Wet Mops Universal Headband Mops Cut-end Rayon Mops | Rough Floor Mops Universal Headband Mops Cut-end Blend Mops | Microfiber Wet Mops Blend Mops Universal Headband Mops |
| School | Premium Washable Mops Standard Washable Mop Unwashable Disposable Mop | Microfiber Wet Mops Universal Headband Mops Economy Cotton Mops | Rough Floor Mops Universal Headband Mops Cut-end Blend Mops | Microfiber Wet Mops Blend Mops Economy Cotton Mops |
| Industrial and Commercial | Premium Washable Mops Standard Washable Mop Unwashable Disposable Mop | Microfiber Wet Mops Blend Mops Cut-end Blend Mops | Rough Floor Mops Universal Headband Mops Cut-end Blend Mops | Microfiber Wet Mops Blend Mops Cotton Mop without Looped Ends |
| Catering | Premium Washable Mops Standard Washable Mop Unwashable Disposable Mop | Blend Mops Blend Mops Cut-End Blend Mops | Rough Floor Mops Universal Headband Mops Cut-end Blend Mops | Microfiber Wet Mops Blend Mops Synthetic Blend Mops |
| Office Building | Premium Washable Mops Standard Washable Mop Unwashable Disposable Mop | Microfiber Wet Mops Blend Mops Cut-End Blend Mops | Rough Floor Mops Universal Headband Mops Cut-end Blend Mops | Microfiber Wet Mops Blend Mops Cut-End Cotton Mops |
| Hotels | Premium Washable Mops Standard Washable Mop Unwashable Disposable Mop | Microfiber Wet Mops Blend Mops Cut-End Blend Mops | Rough Floor Mops Universal Headband Mops Cut-end Blend Mops | Microfiber Wet Mops Blend Mops Synthetic Blend Mops |
| Gymnasium | Premium Washable Mops Standard Washable Mop Unwashable Disposable Mop | Microfiber Wet Mops Blend Mops Cut-End Blend Mops | Rough Floor Mops Universal Headband Mops Cut-end Blend Mops | Microfiber Wet Mops Blend Mops Cut-End Cotton Mops |
| Club | Premium Washable Mops Standard Washable Mop Unwashable Disposable Mop | Microfiber Wet Mops Blend Mops Cut-End Blend Mops | Rough Floor Mops Universal Headband Mops Cut-end Blend Mops | Microfiber Wet Mops Blend Mops Synthetic Blend Mops |

FOR CLEANING, SCRUBBING AND FINISHING

| Cleaning and Scrubbing | Finish |
|---------------------------------|-------------------|
| Blend Mops | Nylon Finish Mops |
| Premium Mop without Looped Ends | Blend Mops |
| Economy Cotton Mops | Blend Mops |

PREMIUM WASHABLE MOPS:

Allow for average 75-100 laundering and re-use.

STANDARD WASHABLE MOPS:

Allow for average 25-75 laundering and re-use.

UNWASHABLE/DISPOSABLE MOPS:

Laundrying is not suggested.

BLEND MOPS

PRODUCT FEATURES:

1. Outperforms and outlasts premium cut-end mops by a factor of two to one.
2. Balanced blend of cotton and synthetic yarns for higher absorbency and strength.
3. Looped ends and yarn tailband mops have greater floor coverage.



6013

6015

| Model | Description | Mop Size | Headband Size | Headband Color | Mop Color | Pack |
|-------|-------------|----------|---------------|----------------|----------------------|------|
| 6013 | Blend Mop | Medium | 12.7cm | GRN | BLUE , GRN, RED, WHT | 6 |
| 6014 | Blend Mop | Large | 12.7cm | RED | BLUE , GRN, RED, WHT | 6 |
| 6015 | Blend Mop | Medium | 3.2cm | GRN | BLUE , GRN, RED, WHT | 6 |
| 6016 | Blend Mop | Large | 3.2cm | RED | BLUE , GRN, RED, WHT | 6 |

COTTON MOPS

PRODUCT FEATURES:

1. Excellent, all-purpose mop for general cleaning.
2. Looped ends reduce fraying associated with cut-end mops.



6023

6025

| Model | Description | Mop Size | Headband Size | Headband Color | Mop Color | Pack |
|-------|-------------|----------|---------------|----------------|-----------|------|
| 6023 | Cotton Mop | Medium | 12.7cm | GRN | WHT | 12 |
| 6024 | Cotton Mop | Large | 12.7cm | RED | WHT | 12 |
| 6025 | Cotton Mop | Medium | 3.2cm | GRN | WHT | 12 |
| 6026 | Cotton Mop | Large | 3.2cm | RED | WHT | 12 |

SUPERFINE FIBER MOPS

PRODUCT FEATURES:

1. Looped ends and yarn tailband mops have greater floor coverage.
2. Soft and elastic fiber won't cause the slightest damage to the cleaning surface.
3. Excellent absorbency, strong dirt-removal performance and long service life.



6033

| Model | Description | Mop Size | Headband Size | Headband Color | Mop Color | Pack |
|-------|---------------------|----------|---------------|----------------|-----------|------|
| 6033 | Superfine Fiber Mop | Medium | 12.7cm | GRN | WHT | 12 |
| 6034 | Superfine Fiber Mop | Large | 12.7cm | RED | WHT | 12 |
| 6035 | Superfine Fiber Mop | Medium | 3.2cm | GRN | WHT | 12 |
| 6036 | Superfine Fiber Mop | Large | 3.2cm | RED | WHT | 12 |

ECONOMY COTTON MOPS

PRODUCT FEATURES:

1. Economical cut-end mops.
2. Cotton mops for various cleaning applications.



6112



6113

| Model | Description | Mop Size | Headband Size | Headband Color | Mop Color | Pack |
|-------|---------------------------|----------|---------------|----------------|-----------|------|
| 6112 | Economy Cotton Mop, Small | Small | 12.7cm | WHT | WHT | 12 |
| 6113 | Economy Cotton Mop, Small | Small | 3.2cm | WHT | WHT | 12 |

FINISH MOPS

PRODUCT FEATURES:

1. Suitable for floor finish application.
2. Balanced blend of cotton and synthetic yarns ensures higher absorbency and strength.
3. Bright blue and white yarn helps color code the finish mop from general-purpose mops.
4. Looped ends with yarn tailband ensure greater coverage with each stroke and help reduce streaking.
5. Tightly twisted, 4-ply yarn helps reduce linting.



6043

| Model | Description | Mop Size | Headband Size | Headband Color | Mop Color | Pack |
|-------|-------------|----------|---------------|----------------|-----------|------|
| 6043 | Finish Mop | Medium | 12.7cm | BLUE | BLUE/WHT | 6 |
| 6044 | Finish Mop | Medium | 3.2cm | BLUE | BLUE/WHT | 6 |

CLEAN ROOM MOPS

PRODUCT FEATURES:

1. Looped ends and yarn tailband mop for greater floor coverage with each stroke.
2. For use in Class 10, 000 and higher industrial applications such as paint booths, pharmaceutical labs, etc.
3. Made of a woven/rayon/polyester fabric that will not fray or lint.
4. Washable and pre-shrunk for long product life.



6053

| Model | Description | Mop Size | Headband Size | Headband Color | Mop Color | Pack |
|-------|------------------------|----------|---------------|----------------|-----------|------|
| 6053 | Clean Room Mop, Medium | Medium | 12.7cm | GRN | WHT | 12 |
| 6054 | Clean Room Mop, Large | Large | 12.7cm | RED | WHT | 12 |
| 6055 | Clean Room Mop, Medium | Medium | 3.2cm | GRN | WHT | 12 |
| 6056 | Clean Room Mop, Large | Large | 3.2cm | RED | WHT | 12 |

SUPERFINE FIBER MOPS

PRODUCT FEATURES:

1. Quality superfine fibers effectively remove bacteria.
2. Absorbency up to ten times its weight.
3. Effectively enhances the performance of chemical cleansers.
4. Free of lint.
5. Extra-strong mildew-resistance.
6. Comes with tailband (6062/6063) to ensure greater coverage with each stroke.
7. 6064 can work in couple with 6351/6352/6353/6388 handles.

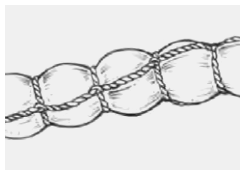

Innovative **yarn spinning technology** ensures excellent absorbency and strong dirt-removal

| Model | Description | Mop Size | Headband Size | Headband Color | Mop Color | Pack |
|-------|---|----------|---------------|----------------|-----------|------|
| 6062 | Super Fiber Mop | Medium | 12.7cm | GRN | WHT | 12 |
| 6063 | Super Fiber Mop | Large | 12.7cm | RED | WHT | 12 |
| 6064 | Super Fiber Mop With Plastic Threaded Tip | Medium | 5.4 × 3.8cm | BLUE | WHT | 12 |
| 6065 | Super Fiber Mop | Medium | 3.2cm | GRN | WHT | 12 |
| 6066 | Super Fiber Mop | Large | 3.2cm | RED | WHT | 12 |

MICROFIBER TUBE MOPS

PRODUCT FEATURES:

1. Blend of microfiber and polyester.
2. More durable than traditional blend mops and can withstand three times the number of launderings than traditional blend mops.
3. Superior absorbency and release.
4. Tube shape reduces drag effectively.

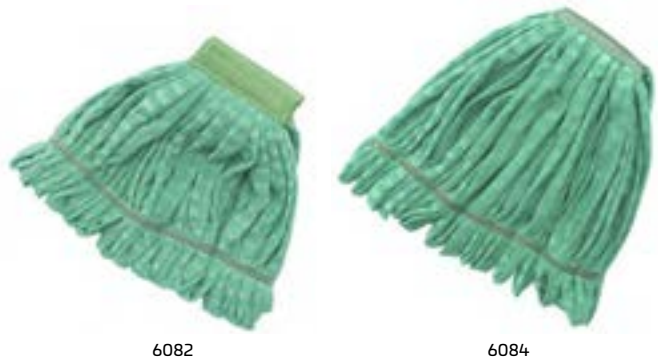

| Model | Description | Mop Size | Headband Size | Headband Color | Mop Color | Pack |
|-------|---------------------|----------|---------------|----------------|-----------|------|
| 6082 | Microfiber Tube Mop | Medium | 12.7cm | GRN | GRN | 6 |
| 6083 | Microfiber Tube Mop | Large | 12.7cm | RED | GRN | 6 |
| 6084 | Microfiber Tube Mop | Medium | 3.2cm | GRN | GRN | 6 |
| 6085 | Microfiber Tube Mop | Large | 3.2cm | RED | GRN | 6 |



MICROFIBER STRING MOPS

PRODUCT FEATURES:

1. Blend of microfiber and cotton
2. Washable, resistant to shrinking
3. More durable than traditional blend mops and can withstand twice the number of launderings than traditional blend mops.
4. Superior absorbency and release.



6092

6094

| Model | Description | Mop Size | Headband Size | Headband Color | Mop Color | Pack |
|-------|-----------------------|----------|---------------|----------------|-----------|------|
| 6092 | Microfiber String Mop | Medium | 12.7cm | GRN | GRN | 6 |
| 6093 | Microfiber String Mop | Large | 12.7cm | RED | GRN | 6 |
| 6094 | Microfiber String Mop | Medium | 3.2cm | GRN | GRN | 6 |
| 6095 | Microfiber String Mop | Large | 3.2cm | RED | GRN | 6 |

QUICK CONNECT MOPS

PRODUCT FEATURES:

1. Quick-connect mops are fit for general cleaning.
2. Quick-connect design makes assembly and replacement easier.
3. Looped-ends and yarn tailband mop have greater floor coverage.
4. Balanced blend of cotton and synthetic yarns for higher absorbency, efficiency and longer product life.
5. Works with wringers (5211/5223/5226).
6. Optional handles (6413/6414) available, which are sold separately.



6072

| Model | Description | Mop Size | Headband Size | Headband Color | Mop Color | Pack |
|-------|-------------------|----------|---------------|----------------|---------------------|------|
| 6072 | Quick Connect Mop | Medium | N/A | N/A | BLUE, GRN, RED, WHT | 24 |
| 6073 | Quick Connect Mop | Large | N/A | N/A | BLUE, GRN, RED, WHT | 24 |



SYNTHETIC FIBER MOPS

PRODUCT FEATURES:

1. Synthetic fiber for excellent water absorption and a long service life.
2. Looped-ends and yarn tailband mops have greater floor coverage.



6133



6135

| Model | Description | Mop Size | Headband Size | Headband Color | Mop Color | Pack |
|-------|---------------------|----------|---------------|----------------|----------------------|------|
| 6133 | Synthetic Fiber Mop | Medium | 12.7cm | GRN | BLUE , GRN, RED, WHT | 6 |
| 6134 | Synthetic Fiber Mop | Large | 12.7cm | RED | BLUE , GRN, RED, WHT | 6 |
| 6135 | Synthetic Fiber Mop | Medium | 3.2cm | GRN | BLUE , GRN, RED, WHT | 6 |
| 6136 | Synthetic Fiber Mop | Large | 3.2cm | RED | BLUE , GRN, RED, WHT | 6 |

ANTIBIOTIC BLENDED MOPS

PRODUCT FEATURES:

1. Integrated antibiotic protection effectively inhibits the growth of bacteria, prevents odors and extends life cycle.
2. Made of a blend of polyester, antibiotic acrylic fibers and cotton.
3. Very moisture-absorbing, durable and effective cleaning.
4. Washable, resistant to shrinking.
5. Looped ends and yarn tailband mop for greater floor coverage with each stroke.



6103



6105

| Model | Description | Mop Size | Headband Size | Headband Color | Mop Color | Pack |
|-------|------------------------|----------|---------------|----------------|-----------|------|
| 6103 | Antibiotic Blended Mop | Medium | 12.7cm | GRN | GRN | 6 |
| 6104 | Antibiotic Blended Mop | Large | 12.7cm | RED | GRN | 6 |
| 6105 | Antibiotic Blended Mop | Medium | 3.2cm | GRN | GRN | 6 |
| 6106 | Antibiotic Blended Mop | Large | 3.2cm | RED | GRN | 6 |

ANTIBIOTIC MICROFIBER MOPS

PRODUCT FEATURES:

1. Integrated antibiotic protection inhibits the growth of bacteria, prevents odors and extends life cycle.
2. Blended polyester-nylon composite yarns and antibiotic acrylic fibers.
3. Very moisture-absorbing, durable and effective cleaning.
4. Washable, resistant to shrinking.
5. Looped ends and yarn tailband mop for greater floor coverage with each stroke.



6123



6125

| Model | Description | Mop Size | Headband Size | Headband Color | Mop Color | Pack |
|-------|---------------------------|----------|---------------|----------------|-----------|------|
| 6123 | Antibiotic Microfiber Mop | Medium | 12.7cm | GRN | GRN | 6 |
| 6124 | Antibiotic Microfiber Mop | Large | 12.7cm | RED | GRN | 6 |
| 6125 | Antibiotic Microfiber Mop | Medium | 3.2cm | GRN | GRN | 6 |
| 6126 | Antibiotic Microfiber Mop | Large | 3.2cm | RED | GRN | 6 |





SIDE GATE MOP HANDLES

PRODUCT FEATURES:

1. Large plastic mop head and threaded-tight structure ensures that the mop is held securely in place.
2. The handle is made from light and durable high-performance composite material.
3. Patented design allows for easy mop replacement.
4. Suitable for mops with headband size of 3.2cm.



6311



| Model | Description | Dimensions | Capacity | Color | Pack |
|-------|----------------------|------------|----------|---------------------------|------|
| 6311 | Side Gate Mop Handle | 137.0cm | N/A | BLUE, GRAY, GRN, RED, YEL | 12 |
| 6312 | Side Gate Mop Handle | 152.0cm | N/A | BLUE, GRAY, GRN, RED, YEL | 12 |
| 6313 | Side Gate Mop Handle | 137.0cm | N/A | LAC | 12 |
| 6314 | Side Gate Mop Handle | 152.0cm | N/A | LAC | 12 |
| 6315 | Side Gate Mop Handle | 137.0cm | N/A | MSILV | 12 |
| 6316 | Side Gate Mop Handle | 152.0cm | N/A | MSILV | 12 |

CLAMP STYLE MOP HANDLES

PRODUCT FEATURES:

1. Threaded-tight structure ensures that the mop is held securely in place..
2. The handle is made from light and durable high-performance composite material.
3. Threaded-bolt head for quick and easy mop changes.
4. Suitable for mops with headband size of 12.7cm.



6321



| Model | Description | Dimensions | Capacity | Color | Pack |
|-------|------------------------|------------|----------|---------------------------|------|
| 6321 | Clamp Style Mop Handle | 137.0cm | N/A | BLUE, GRAY, GRN, RED, YEL | 12 |
| 6322 | Clamp Style Mop Handle | 137.0cm | N/A | BLUE, GRAY, GRN, RED, YEL | 12 |
| 6323 | Clamp Style Mop Handle | 152.0cm | N/A | BLUE, GRAY, GRN, RED, YEL | 12 |
| 6324 | Clamp Style Mop Handle | 152.0cm | N/A | BLUE, GRAY, GRN, RED, YEL | 12 |
| 6325 | Clamp Style Mop Handle | 137.0cm | N/A | LAC | 12 |
| 6326 | Clamp Style Mop Handle | 152.0cm | N/A | LAC | 12 |
| 6327 | Clamp Style Mop Handle | 137.0cm | N/A | MSILV | 12 |
| 6328 | Clamp Style Mop Handle | 152.0cm | N/A | MSILV | 12 |

HINGED SIDE GATE MOP HANDLES

PRODUCT FEATURES:

1. Thumb release mechanism permits mop replacement without touching the dirty mop.
2. The handle is made from light and durable high-performance composite material.
3. Suitable for mops with headband size of 3.2cm.



6331



Thumb release mechanism permits mop replacement without touching dirty mop

| Model | Description | Dimensions | Capacity | Color | Pack |
|-------|-----------------------------|------------|----------|-------|------|
| 6331 | Hinged Side Gate Mop Handle | 137.0cm | N/A | BLUE | 12 |
| 6332 | Hinged Side Gate Mop Handle | 152.0cm | N/A | BLUE | 12 |

STEEL MOP HANDLES

PRODUCT FEATURES:

1. Durable corrosion-resistant metal head.
2. 137cm and 152cm lengths optional.
3. Suitable for mops with headband size of 3.2cm.



6341

| Model | Description | Dimensions | Capacity | Color | Pack |
|-------|-----------------------------------|------------|----------|-------|------|
| 6341 | Steel Mop Handle, Hardwood Handle | 137.0cm | N/A | LAC | 12 |
| 6342 | Steel Mop Handle, Hardwood Handle | 152.0cm | N/A | LAC | 12 |

NAELC® ALUMINUM QUICK CONNECT HANDLES



PRODUCT FEATURES:

1. Lightweight aluminum construction enhances cleaning efficiency.
2. Quick-connect design makes assembly and replacement easier.
3. Ergonomically designed handles are comfortable and easily maneuverable.
4. 6415 can be used with TRUST threaded tools.



6413



Quick-connect Adapter (6415) can be used with TRUST threaded tools

| Model | Description | Dimensions | Capacity | Color | Pack |
|-------|--------------------------------------|-------------|----------|---------------------------|------|
| 6413 | NAELC® Aluminum Quick Connect Handle | 132.0cm | N/A | BLUE, GRAY, GRN, RED, YEL | 12 |
| 6414 | NAELC® Aluminum Quick Connect Handle | 147.0cm | N/A | BLUE, GRN, RED, YEL | 12 |
| 6415 | Quick-connect Adapter | 3.3 x 9.5cm | N/A | BLA | 3 |



DUST MOP SELECTION GUIDE

SELECTING THE BEST CLEANING TOOLS FOR YOUR FACILITY:

The guide below provides some key factors to consider when selecting the most suitable dust mop for your floor.

| Facility | Best | Better | Good |
|---------------------------|---------------------|--------------------|--------------------|
| Hotels | Microfiber Dust Mop | Synthetic Dust Mop | Blended Dust Mop |
| Catering | Microfiber Dust Mop | Synthetic Dust Mop | Blended Dust Mop |
| Health Care | Microfiber Dust Mop | Blended Dust Mop | Synthetic Dust Mop |
| Industrial and Commercial | Microfiber Dust Mop | Synthetic Dust Mop | Blended Dust Mop |
| School | Microfiber Dust Mop | Synthetic Dust Mop | Synthetic Dust Mop |
| Office Building | Microfiber Dust Mop | Synthetic Dust Mop | Blended Dust Mop |

GENERAL DUST MOPPING:

Durable dust mops with high dust pick-up capacity are preferred. If permitted, washable dust mops are the most cost-efficient choice. Twisted loop mops, reinforced stitching and easily attachable backing units are factors that contribute to superior cleaning and performance.



TWISTED LOOP END

For optimal cleaning of dust and dirt. Twisted loops resist snagging, fraying or unravelling while laundering.



CUT ENDS

Economical construction for general purpose dusting.



REINFORCED STITCHING

Add reinforced stitching on easily-wearing parts for extended service life.



BACKING DESIGN

Backing for easy attaching and detaching from the frame helps improve cleaning efficiency.

LAUNDERABILITY

Laundryability is the number of times a dust mop can be laundered and dried before it becomes worn out, or is under-performing.

Synthetic and blended dust mops have the highest laundryability.

DURABILITY

Durability is indicated by the length of time that passes before it is necessary to replace a worn dust mop.

Synthetic and blended Mops have the highest durability.

Antimicrobial fiber mops are more durable thanks to their capability to inhibit the growth of bacteria, reduce odor and prevent fading.

DUST PICK UP

Dust Pick-up Performance means the mop's capacity to pick up dirt and dust from the floor.

Synthetic and blended Mops have the best dust pick-up performance.

NAELC® QUICK CONNECT HANDLES

PRODUCT FEATURES:

1. Lightweight aluminum construction.
2. Telescopic handle for cleaning high places.
3. 6415 can be used with TRUST threaded tools.



Quick-connect Adapter (6415) can be used with TRUST threaded tools



6411



6412



6416



6417

| Model | Description | Dimensions | Capacity | Color | Pack |
|-------|--|--|----------|-------|------|
| 6411 | NAELC® 51.0-102.0cm Quick-connect Short Extension Handle | Open: 102.0 × 5.1 × 5.1cm Closed: 68.0 × 5.1 × 5.1cm | N/A | YEL | 6 |
| 6412 | NAELC® 122.0-183.0cm Quick-connect Straight Extension Handle | Open: 183.0 × 5.1 × 5.1cm Closed: 132.0 × 5.1 × 5.1cm | N/A | YEL | 6 |
| 6416 | NAELC® 122.0-235.0cm Quick-connect Straight Extension Handle | Open: 235.0 × 5.3 × 5.3cm Closed: 122.0 × 5.3 × 5.3cm | N/A | YEL | 6 |
| 6417 | NAELC® 180.0-360.0cm Quick-connect Straight Extension Handle | Open: 360.0 × 5.3 × 5.3cm Closed: 180.0 × 5.3 × 5.3cm | N/A | YEL | 6 |
| 6415 | Quick-connect Adapter | 3.3 × 9.5cm | N/A | BLA | 3 |

NAELC® QUICK CONNECT FRAMES

PRODUCT FEATURES:

1. Lightweight aluminum construction.
2. Designed with a round plastic cover on both ends to protect walls and furniture.



6421



6422

| Model | Description | Dimensions | Capacity | Color | Pack |
|-------|--|---------------------|----------|-------|------|
| 6420 | NAELC® 28.0cm Quick-connect Wall/Stair Frame | 28.0 × 8.9 × 3.8cm | N/A | BLA | 6 |
| 6421 | NAELC® 46.0cm Quick-connect Frame | 46.0 × 8.9 × 3.8cm | N/A | BLA | 6 |
| 6422 | NAELC® 61.0cm Quick-connect Frame | 61.2 × 8.9 × 3.8cm | N/A | BLA | 6 |
| 6423 | NAELC® 91.0cm Quick-connect Frame | 91.7 × 8.9 × 3.8cm | N/A | BLA | 6 |
| 6424 | NAELC® 122.0cm Quick-connect Frame | 122.2 × 8.9 × 3.8cm | N/A | BLA | 6 |
| 6425 | NAELC® 152.0cm Quick-connect Frame | 152.4 × 8.9 × 3.8cm | N/A | BLA | 6 |

DUST MOPS

NAELC® DUST MOPS

PRODUCT FEATURES:

1. High cleaning performance.
2. Looped end construction increases the cleaning coverage and reduces linting.
3. Foam-like edge and 5cm-long fringe help remove large amounts of dust and dirt.
4. Fully washable in water up to 93°C.

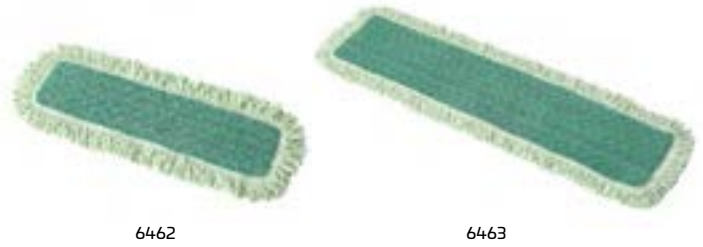

| Model | Description | Dimensions | Capacity | Color | Pack |
|-------|--|----------------------|----------|-------|------|
| 6461 | NAELC® 46.0cm Microfiber Fringed Dust Mop | 54.5 × 22.9 × 1.3cm | N/A | GRN | 6 |
| 6462 | NAELC® 61.0cm Microfiber Fringed Dust Mop | 71.1 × 22.9 × 1.3cm | N/A | GRN | 6 |
| 6463 | NAELC® 91.0cm Microfiber Fringed Dust Mop | 101.6 × 22.9 × 1.3cm | N/A | GRN | 6 |
| 6464 | NAELC® 122.0cm Microfiber Fringed Dust Mop | 132.1 × 22.9 × 1.3cm | N/A | GRN | 6 |
| 6465 | NAELC® 152.0cm Microfiber Fringed Dust Mop | 162.6 × 22.9 × 1.3cm | N/A | GRN | 6 |

NAELC® DRY MOPS

PRODUCT FEATURES:

1. 100% superfine fiber.
2. With foam-like edges for removing dust and dirt from irregular corners.
3. Large dusting pads (6472/6473/6474) have greater cleaning coverage by 40% than the comparative.



| Model | Description | Dimensions | Capacity | Color | Pack |
|-------|---|----------------------|----------|----------|------|
| 6471 | NAELC® 46.0cm Microfiber Room Dust Mop | 47.0 × 14.0 × 1.3cm | N/A | GRN, WHT | 12 |
| 6472 | NAELC® 61.0cm Microfiber Hall Dust Mop | 62.2 × 14.0 × 1.3cm | N/A | GRN | 12 |
| 6473 | NAELC® 91.0cm Microfiber Hall Dust Mop | 92.7 × 14.0 × 1.3cm | N/A | GRN | 12 |
| 6474 | NAELC® 122.0cm Microfiber Hall Dust Mop | 123.2 × 14.0 × 1.3cm | N/A | GRN | 12 |

NAELC® WET MOPS

PRODUCT FEATURES:

1. 100% superfine fiber.
2. Special handling mop surface (6501) effectively cleans stains from floor surfaces.
3. Compared with a traditional mop, it reduces 95% of the chemical usage.
4. Compared with a traditional wet mop, it saves 90% water.
5. It has a longer service life and higher cleaning efficiency when used together with a bleach and water solution.
6. Without bleach the mops can be repeatedly washed up to 500 times, or up to 200 times when used together with bleach.
7. Washable in water up to 93°C without bleach solution.
8. Various mop colors available to help reduce the risk of cross contamination between work areas.



Innovated **blue rigid string** to remove stubborn stains effectively

| Model | Description | Dimensions | Capacity | Color | Pack |
|-------|---|---------------------|----------|----------------|------|
| 6500 | NAELC® 28cm Microfiber Damp Room Mop | 34.8 × 14.0 × 1.3cm | N/A | BLUE | 6 |
| 6501 | NAELC® 46cm Microfiber Super Scrubber Mop | 50.8 × 14.0 × 1.3cm | N/A | YEL | 6 |
| 6502 | NAELC® 46cm Microfiber Damp Room Mop | 53.5 × 15.2 × 1.3cm | N/A | BLUE, GRN, RED | 12 |
| 6503 | NAELC® 61cm Microfiber Damp Room Mop | 62.2 × 14.0 × 1.3cm | N/A | BLUE | 12 |

NAELC® DUST MOP HANDLES AND DUST MOP FRAMES

PRODUCT FEATURES:

1. Corrosion-resistant, powder-coated dust mop frames allow for durable performance.
2. Spring-loaded clip easily attaches to the dust mop frame.
3. Sliding collar locks the handle into position or allow for a full 360° swivel action.
4. Available in easily sanitized hardwood handle.

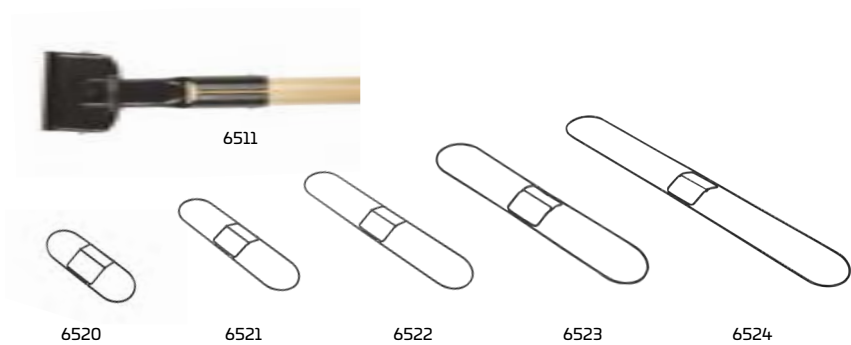

| Model | Description | Dimensions | Capacity | Color | Pack |
|-------|-------------------------------------|----------------|----------|-------|------|
| 6511 | NAELC® Snap-on Wire Dust Mop Handle | 152.4cm | N/A | LAC | 12 |
| 6513 | NAELC® Snap-on Wire Dust Mop Handle | 152.4cm | N/A | MSILV | 12 |
| 6520 | NAELC® Dust Mop Frame | 30.5 × 12.7cm | N/A | BLA | 12 |
| 6521 | NAELC® Dust Mop Frame | 45.7 × 12.7cm | N/A | BLA | 12 |
| 6522 | NAELC® Dust Mop Frame | 61.0 × 12.7cm | N/A | BLA | 12 |
| 6523 | NAELC® Dust Mop Frame | 91.4 × 12.7cm | N/A | BLA | 12 |
| 6524 | NAELC® Dust Mop Frame | 121.9 × 12.7cm | N/A | BLA | 12 |

NAELC® DUST MOPS

PRODUCT FEATURES:

1. Premium dust mop for general-purpose dust mopping
2. Pre-treated and pre-shrunk.
3. Fully washable for a longer service life.
4. Envelope-end backing style.
5. All sewn construction.



| Model | Description | Dimensions | Capacity | Color | Pack |
|-------|-----------------|----------------|----------|-----------|------|
| 6530 | NAELC® Dust Mop | 34.0 × 14.5cm | N/A | BLUE, WHT | 12 |
| 6531 | NAELC® Dust Mop | 47.0 × 14.5cm | N/A | BLUE, WHT | 12 |
| 6532 | NAELC® Dust Mop | 65.0 × 14.5cm | N/A | BLUE, WHT | 12 |
| 6533 | NAELC® Dust Mop | 95.0 × 14.5cm | N/A | BLUE, WHT | 12 |
| 6534 | NAELC® Dust Mop | 125.0 × 14.5cm | N/A | BLUE, WHT | 12 |

WEDGE DUST MOPS

PRODUCT FEATURES:

1. Suitable for corners, around the bottom of appliances and behind furniture.
2. Galvanized iron wire frame and wooden handle.
3. Envelope-end backing design.



| Model | Description | Dimensions | Capacity | Color | Pack |
|-------|-------------------------------------|------------|----------|-------|------|
| 6512 | Wedge Mop Handle and Frame | N/A | N/A | LAC | 12 |
| 6561 | Wedge Mop Dust Mop Head, Looped-end | N/A | N/A | YEL | 12 |
| 6562 | Wedge Dust Mop Head, Cut-end | N/A | N/A | YEL | 12 |

MICROFIBER CLEANING SYSTEM



MICROFIBER TECHNOLOGY

Microfiber is an extremely thin thread - 10, 000 meters of which weighs just 1 gramme! By way of comparison: microfibers are twice as fine as silk fibers (the thinnest natural fiber), 3 times finer than cotton fibers and 200 times finer than a human hair. As a result, they offer a much greater “contact surface” for dirt absorption than the fibers commonly used in mops and cloths.

Due to their fineness, microfibers develop a mechanical cleaning action even in the micropores of surfaces which cannot be registered by the human eye. They easily capture dirt thanks to their hair-like scaly structure.

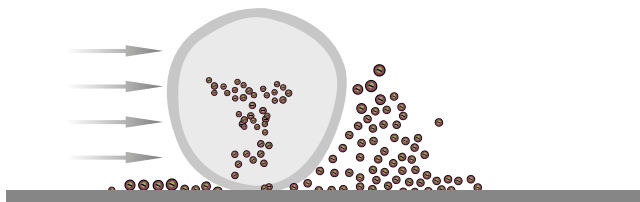

ORDINARY FIBER
leaves dirt behind after cleaning

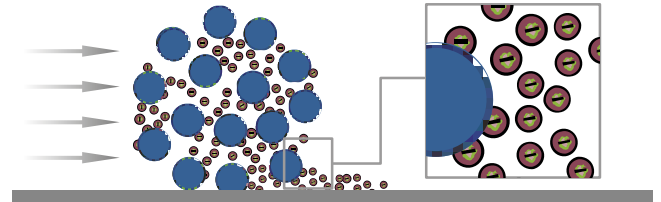

MICROFIBER
wipes away more than 99.99% of bacteria and dirt



Proven Performance To Ensure Healthy, Safe Environments

- Superior microfiber proven to remove microorganisms
- Helps reduce cross-transmission
- Withstands up to 500 commercial launderings

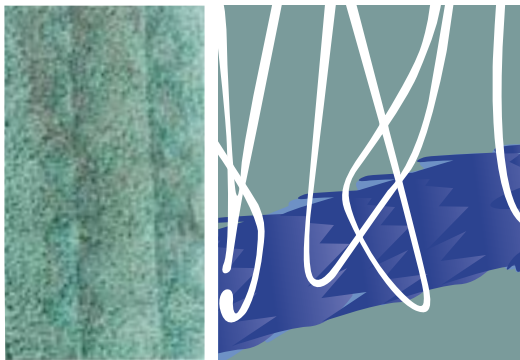

The high-quality microfiber amazing cleaning results, so that the floor becomes more bright.

Premium superfine fibers make your floor brighter

Increase the cleanliness of floors by 45% when compared to regular mops.

25% better cleaning effects than traditional microfiber dust pads

Sustainable Development Low Cost and High Benefits

Economic Return: Use with water only. Save the cost of chemical detergent by 90%. Cut the cost for disposable items and relevant garbage disposal expense.

Social Welfare: Improve the health and safety of operators by eliminating the use of chemical detergents.

Environment Benefit: Reduce pollution to the environment by reducing the consumption of water and avoiding the use of chemical detergents.

Effectively removes over 99.9% of bacteria and dirt with less water (only 1.5L for every 250 m².)



U-RAG® MICROFIBER CLOTHS



PRODUCT FEATURES:

1. Double finished edges add durability.
2. Durable construction withstands more than 500 launderings.
3. Allows for a sterilization in 100°C hot water without bleaching agent.
4. Color coded products help reduce cross-contamination by differentiating area of use.



| Model | Description | Dimensions | Capacity | Color | Pack |
|-------|--|---------------|----------|----------------|------|
| 6431 | U-RAG® Microfiber Bathroom Cloth | 40.6 × 40.6cm | N/A | YEL | 12 |
| 6432 | U-RAG® Microfiber General Purpose Cloth | 40.6 × 40.6cm | N/A | BLUE, GRN, RED | 12 |
| 6433 | U-RAG® Microfiber Glass/Mirror Cloth | 40.6 × 40.6cm | N/A | BLUE | 12 |
| 6434 | U-RAG® Microfiber XL General Purpose Cloth | 50.8 × 50.8cm | N/A | GRN | 12 |
| 6435 | U-RAG® Microfiber Bathroom Cloth | 30.0 × 30.0cm | N/A | YEL | 12 |
| 6436 | U-RAG® Microfiber General Purpose Cloth | 30.0 × 30.0cm | N/A | BLUE, GRN, RED | 12 |
| 6437 | U-RAG® Microfiber Glass/Mirror Cloth | 30.0 × 30.0cm | N/A | BLUE | 12 |

U-RAG® LIGHT MICROFIBER CLEANING CLOTHS



PRODUCT FEATURES:

1. Microfiber technology optimizes the effect of cleaning.
2. Washable and reusable up to 100 times.
3. Bleach as needed.
4. More effective at cleaning than cotton cloths up to 30%.
5. Effective at capturing up to 99.9% of bacteria.
6. Reduces chemical use more effectively.



| Model | Description | Dimensions | Capacity | Color | Pack |
|-------|--|---------------|----------|-------|------|
| 6485 | U-RAG® Light Microfiber Cleaning Cloth | 40.6 × 40.6cm | N/A | RED | 144 |
| 6486 | U-RAG® Light Microfiber Cleaning Cloth | 40.6 × 40.6cm | N/A | YEL | 144 |
| 6487 | U-RAG® Light Microfiber Cleaning Cloth | 40.6 × 40.6cm | N/A | BLUE | 144 |
| 6488 | U-RAG® Light Microfiber Cleaning Cloth | 40.6 × 40.6cm | N/A | GRN | 144 |
| 6571 | U-RAG® Light Microfiber Cleaning Cloth | 30.0 × 30.0cm | N/A | RED | 144 |
| 6572 | U-RAG® Light Microfiber Cleaning Cloth | 30.0 × 30.0cm | N/A | YEL | 144 |
| 6573 | U-RAG® Light Microfiber Cleaning Cloth | 30.0 × 30.0cm | N/A | BLUE | 144 |
| 6574 | U-RAG® Light Microfiber Cleaning Cloth | 30.0 × 30.0cm | N/A | GRN | 144 |



U-RAG® SUPERFINE FIBER CLOTHS

PRODUCT FEATURES:

1. Superfine fiber cloth offers optimized cleaning performance.
2. Rinsable and reusable, withstands washing up to 40 times.
3. Bleach cleaning safe.
4. 30% higher decontamination capabilities than cotton rag.
5. Removes more than 99.9% of the bacteria and dirt.
6. Reduces the use of chemical cleansers.
7. Extends service life, reduces the use of paper towels.



| Model | Description | Dimensions | Capacity | Color | Pack |
|-------|------------------------------|---------------|----------|-------|------|
| 6481 | U-RAG® Superfine Fiber Cloth | 48.3 × 40.6cm | N/A | RED | 144 |
| 6482 | U-RAG® Superfine Fiber Cloth | 48.3 × 40.6cm | N/A | YEL | 144 |
| 6483 | U-RAG® Superfine Fiber Cloth | 48.3 × 40.6cm | N/A | BLUE | 144 |
| 6484 | U-RAG® Superfine Fiber Cloth | 48.3 × 40.6cm | N/A | GRN | 144 |

U-RAG® MICROFIBER MITTS

PRODUCT FEATURES:

1. Reach into crevices and irregular surfaces for easy cleaning.
2. 6441 fit for general cleaning.
3. 6442 fit for glass or chrome-plated surface cleaning.
4. 6443 fit for dry dusting cleaning.



6441

6442

6443

| Model | Description | Dimensions | Capacity | Color | Pack |
|-------|--|---------------|----------|-------|------|
| 6441 | U-RAG® Microfiber All Purpose Mitt with Thumb | 27.9 × 22.2cm | N/A | GRN | 12 |
| 6442 | U-RAG® Microfiber Glass/Mirror Mitt with Thumb | 27.9 × 22.2cm | N/A | BLUE | 12 |
| 6443 | U-RAG® Microfiber Dusting Mitt with Thumb | 30.2 × 25.1cm | N/A | GRN | 6 |



MICROFIBER CLEANING SYSTEM

U-RAG® MICROFIBER DUSTERS

PRODUCT FEATURES:

1. Reach into crevices and awkward places to remove dust, dirt and allergens.
2. Replacement sleeves are washable.
3. Handles may be bent to any angle for high cleaning efficiency.
4. Quick-connect dusting wand can be changed to a long handle.
5. 6453 is effective in cleaning extreme-dirt areas and removing hairs or large debris.



6451

6453

| Model | Description | Dimensions | Capacity | Color | Pack |
|-------|---|---------------------|----------|-------|------|
| 6451 | U-RAG® Quick-connect Flexible Dusting Wand with Microfiber Sleeve | 70.5 × 8.3 × 2.9cm | N/A | GRN | 6 |
| 6452 | U-RAG® Wand Duster Microfiber Replacement Sleeve | 54.0 × 8.3 × 1.9cm | N/A | GRN | 6 |
| 6453 | U-RAG® Quick-connect Flexible Dusting Wand with High Performance Sleeve | 72.1 × 11.0 × 2.9cm | N/A | WHT | 6 |
| 6454 | U-RAG® Wand Duster High Performance Microfiber Replacement Sleeve | 57.7 × 11.0 × 2.8cm | N/A | WHT | 6 |

LAUNDRY NETS

PRODUCT FEATURES:

1. Helps protect mops and other cleaning items during laundering.



6986

| Model | Description | Dimensions | Capacity | Color | Pack |
|-------|-------------|---------------|----------|-------|------|
| 6986 | Laundry Net | 91.4 × 61.0cm | N/A | WHT | 12 |





BROOMS AND BRUSHES

BROOMS AND BRUSHES COMPONENTS

To improve cleaning productivity it is important to select the correct brooms and brushes to suit the floor material and the kinds of dirt. TRUST provides you with a wide range of brush heads and bristles to suit all kinds of floors.

BLOCK STRUCTURES



PLASTIC FOAM BLOCKS

Lightweight, textured surface, durable, resists splitting, deforming and decaying, non-absorbent, extended service life.



WOODEN BODIES

Conventional appearance, resists splitting, vulnerable to decay and mildew.

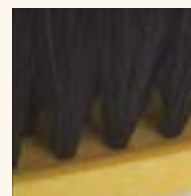

INJECTION-MOLDED BLOCKS

Durable, resists splitting, deforming and decaying, non-absorbent, resists bacteria, extended service life.





BRISTLES - NATURAL MATERIALS



HORSEHAIRS

The ends are subject to special treatment to resist breaking and add durability; Resists scratching even on smooth and polished floor; Not fit for applications on oily or warm surfaces.



PALM LEAVES

Palm leaf fibers of medium to high stiffness are easy to restore to their original form after use; Fit for use on either wet or dry surfaces.



TAMPICO FIBERS

Soft and medium stiffness Tampico fibers are easy to restore to their original form after use; Resists heat, alkaline, solvents and acid; Fit for use on either wet or dry surfaces.

BRISTLES - SYNTHETIC FIBERS



NYLONS

Very durable and resistant to wear or breaking; Bristles are easy to restore its original form after operation; Resists stain, fade or odor; Fit for use on either wet or dry surfaces; Resists alkaline and most solvents.



POLYVINYL CHLORIDES

Very durable and resistant to wear or breaking; Bristles easily restore to their original form after use, resists stain, water and oil solvents; Not fit for use on residential premises or oily surfaces.

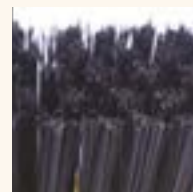

POLYPROPYLENES

Very durable and resistant to wear or breaking; It will neither pollute the floor, nor fade or absorb odors. Resists solvents, acid, oil, bacteria. Fit for use on either wet or dry surfaces.

BRISTLES - METAL WIRES



COPPER

Resists wearing, won't leave scratches on even hard surfaces; Will not rust; Best for cleaning surfaces of metal or brick surfaces which need to be protected from scratching.



STAINLESS STEEL

Resists wearing, water and chemical solutions. Will not rust; Easy to restore its original form after use; Best for tough cleaning jobs such as removal of residues on metals or other persistent dirt.

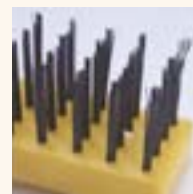

STEEL BRISTLES

Resists wearing or corrosion; Easy to restore its original form after operation; Best for tough cleaning jobs such as removal of residues on metal or bricks.

ANGLE BROOMS

PRODUCT FEATURES:

1. Ideal for cleaning hard-to-reach areas.
2. Long-lasting stain-resistant Polypropylene bristles.
3. 6623 body comes with 2 handle attachment positions for 2 different cleaning purposes.
4. 6624 cleans medium-sized rubbish, such as fine sand across large cleaning areas.
5. Handle is sold separately.



6623

6622

6621

6613

6624

| Model | Description | Dimensions | Capacity | Color | Pack |
|-------|-----------------------------------|------------|----------|----------|------|
| 6613 | Angle Broom, PP Fill | 29.0cm | N/A | YEL | 12 |
| 6621 | Angle Broom with Handle, PET Fill | 19.0cm | N/A | YEL, BLA | 6 |
| 6622 | Angle Broom, PP Fill | 30.0cm | N/A | YEL | 12 |
| 6623 | Angle Broom, PET Fill | 32.0cm | N/A | BLA | 12 |
| 6624 | Angle Broom with Handle, PET Fill | 48.0cm | N/A | BLA | 12 |

FINE FLOOR SWEEPS

PRODUCT FEATURES:

1. Designed to pick up the finest debris.
2. Ideal for highly polished or waxed floors.
3. Two-threaded handle holes on either side of block for even wear.
4. Available in PET or polypropylene, horsehair, Tampico blend.
5. Handle is sold separately.



6632

6643

6634

| Model | Description | Dimensions | Capacity | Color | Pack |
|-------|--|------------|----------|----------|------|
| 6632 | Plastic Foam Block, Fine Floor Sweep, PET Fill | 45.5cm | N/A | YEL, BLA | 12 |
| 6633 | Plastic Foam Block, Fine Floor Sweep, PET Fill | 61.0cm | N/A | YEL, BLA | 12 |
| 6634 | Hardwood Block, Fine Floor Sweep, PET Fill | 92.0cm | N/A | LAC | 2 |
| 6642 | Plastic Foam Block, Fine Floor Sweep, Tampico Fill with Horsehair Border | 45.5cm | N/A | YEL, BLA | 12 |
| 6643 | Plastic Foam Block, Fine Floor Sweep, Tampico Fill with Horsehair Border | 61.0cm | N/A | YEL, BLA | 12 |
| 6644 | Hardwood Block, Fine Floor Sweep, Tampico Fill with Horsehair Border | 92.0cm | N/A | LAC | 2 |

MEDIUM FLOOR SWEEPS

PRODUCT FEATURES:

1. Designed to pick up dirt from multiple floor surfaces.
2. Long-lasting polypropylene and natural Tampico bristles are designed to remove heavier dirt and debris on both rough wood and smooth floor surfaces.
3. Two-threaded handle holes on either side of block for even wear.
4. Available in polypropylene, Tampico, or PET+PP blend.
5. Handle is sold separately.



6672

6663

6674

| Model | Description | Dimensions | Capacity | Color | Pack |
|-------|---|------------|----------|----------|------|
| 6652 | Plastic Foam Block, Medium Floor Sweep, PP Fill | 45.5cm | N/A | YEL, BLA | 12 |
| 6653 | Plastic Foam Block, Medium Floor Sweep, PP Fill | 61.0cm | N/A | YEL, BLA | 12 |
| 6654 | Hardwood Block, Medium Floor Sweep, PP Fill | 92.0cm | N/A | LAC | 2 |
| 6662 | Plastic Foam Block, Medium Floor Sweep, Tampico Fill | 45.5cm | N/A | YEL, BLA | 12 |
| 6663 | Plastic Foam Block, Medium Floor Sweep, Tampico Fill | 61.0cm | N/A | YEL, BLA | 12 |
| 6664 | Hardwood Block, Medium Floor Sweep, Tampico Fill | 92.0cm | N/A | LAC | 2 |
| 6672 | Plastic Foam Block, Medium Floor Sweep, PET and PP Fill | 45.5cm | N/A | YEL, BLA | 12 |
| 6673 | Plastic Foam Block, Medium Floor Sweep, PET and PP Fill | 61.0cm | N/A | YEL, BLA | 12 |
| 6674 | Hardwood Block, Medium Floor Sweep, PET and PP Fill | 92.0cm | N/A | LAC | 2 |

HEAVY-DUTY FLOOR SWEEPS

PRODUCT FEATURES:

1. Reliability for industrial-strength jobs.
2. Heavy-duty polypropylene bristles resist stains and odors.
3. Two-threaded handle holes on either side of block for even wear.
4. Handle is sold separately.



6692

6683

6694

| Model | Description | Dimensions | Capacity | Color | Pack |
|-------|--|------------|----------|----------|------|
| 6682 | Plastic Foam Block, Heavy-duty Floor Sweep, PP Fill | 45.5cm | N/A | YEL, BLA | 12 |
| 6683 | Plastic Foam Block, Heavy-duty Floor Sweep, PP Fill | 61.0cm | N/A | YEL, BLA | 12 |
| 6684 | Hardwood Block, Heavy-duty Floor Sweep, PP Fill | 92.0cm | N/A | LAC | 2 |
| 6692 | Plastic Foam Block, Heavy-duty Floor Sweep, Palmyra Fill | 45.5cm | N/A | YEL, BLA | 12 |
| 6693 | Plastic Foam Block, Heavy-duty Floor Sweep, Palmyra Fill | 61.0cm | N/A | YEL, BLA | 12 |
| 6694 | Hardwood Block, Heavy-duty Floor Sweep, Palmyra Fill | 92.0cm | N/A | LAC | 2 |



LIGHT WOODEN FLOOR SWEEPS

PRODUCT FEATURES:

1. Designed to pick up fine debris, such as sands, sawdust, dusts.
2. Two threaded handle holes on either side of block for even wear.
3. Heavy-duty steel handle bracket ensures strength and durability.
4. Polypropylene bristles resist stains and odors.
5. Zigzag nut prevents loosening.
6. Handle is sold separately.



6871

| Model | Description | Dimensions | Capacity | Color | Pack |
|-------|-----------------------------------|--------------|----------|-------|------|
| 6851 | Light Wooden Floor Sweep, PP Fill | 30.5 × 6.5cm | N/A | LAC | 6 |
| 6861 | Light Wooden Floor Sweep, PP Fill | 40.6 × 9.0cm | N/A | LAC | 6 |
| 6871 | Light Wooden Floor Sweep, PP Fill | 45.7 × 6.0cm | N/A | LAC | 6 |
| 6881 | Light Wooden Floor Sweep, PP Fill | 60.0 × 6.0cm | N/A | LAC | 6 |
| 6891 | Light Wooden Floor Sweep, PP Fill | 60.0 × 7.5cm | N/A | LAC | 6 |

MEDIUM WOODEN FLOOR SWEEPS

PRODUCT FEATURES:

1. Designed to pick up medium-sized debris, such as stones, leaves, and metal.
2. Two threaded handle holes on either side of block for even wear.
3. Heavy-duty steel handle bracket ensures strength and durability.
4. Polypropylene bristles resist stains and odors.
5. Zigzag nut prevents loosening.
6. Handle is sold separately.



6852



6882

| Model | Description | Dimensions | Capacity | Color | Pack |
|-------|------------------------------------|--------------|----------|-------|------|
| 6852 | Medium Wooden Floor Sweep, PP Fill | 30.5 × 6.5cm | N/A | LAC | 6 |
| 6862 | Medium Wooden Floor Sweep, PP Fill | 40.6 × 9.0cm | N/A | LAC | 6 |
| 6872 | Medium Wooden Floor Sweep, PP Fill | 45.7 × 6.0cm | N/A | LAC | 6 |
| 6882 | Medium Wooden Floor Sweep, PP Fill | 60.0 × 6.0cm | N/A | LAC | 6 |
| 6892 | Medium Wooden Floor Sweep, PP Fill | 60.0 × 7.5cm | N/A | LAC | 6 |

HEAVY-DUTY WOODEN FLOOR SWEEPS

PRODUCT FEATURES:

1. Designed to pick up large and heavy debris, such as stones, leaves and straw etc.
2. Two threaded handle holes on either side of block for even wear.
3. Heavy-duty steel handle bracket ensures strength and durability.
4. Polypropylene bristles resist stains and odors.
5. Zigzag nut prevents loosening.
6. Handle is sold separately.



6863

6893



| Model | Description | Dimensions | Capacity | Color | Pack |
|-------|--|--------------|----------|-------|------|
| 6853 | Heavy-duty Wooden Floor Sweep, PP Bristles | 30.5 × 6.5cm | N/A | LAC | 6 |
| 6863 | Heavy-duty Wooden Floor Sweep, PP Bristles | 40.6 × 9.0cm | N/A | LAC | 6 |
| 6873 | Heavy-duty Wooden Floor Sweep, PP Bristles | 45.7 × 6.0cm | N/A | LAC | 6 |
| 6883 | Heavy-duty Wooden Floor Sweep, PP Bristles | 60.0 × 6.0cm | N/A | LAC | 6 |
| 6893 | Heavy-duty Wooden Floor Sweep, PP Bristles | 60.0 × 7.5cm | N/A | LAC | 6 |



TOILET BRUSHES

PRODUCT FEATURES:

1. Available in several handle lengths, head sizes and styles.
2. Polypropylene bristles resist stains and odors.
3. 6798 Toilet Bowl Brushes with TPR non-slip handle offers comfortable handling.



| Model | Description | Dimensions | Capacity | Color | Pack |
|-------|--|------------|----------|----------|------|
| 6791 | Toilet Brush, Hardwood Handle, PP Fill | 43.0cm | N/A | YEL | 12 |
| 6792 | Toilet Brush, Plastic Handle, PP Fill | 42.0cm | N/A | WHT | 24 |
| 6793 | Toilet Brush Holder | 13.5cm | N/A | WHT | 24 |
| 6794 | Toilet Brush, Plastic Handle, PP Fill | 43.0cm | N/A | YEL, BLA | 12 |
| 6795 | Plastic Handle Brush, PP Fill | 51.0cm | N/A | YEL | 12 |
| 6796 | Plastic Handle Brush, PP Fill | 50.0cm | N/A | YEL | 12 |
| 6797 | Plastic Handle Brush, Tampico Fill | 50.0cm | N/A | YEL | 12 |
| 6798 | Toilet Brush, Plastic Handle, PP Fill | 42.0cm | N/A | WHT | 12 |

WIRE BRUSHES

PRODUCT FEATURES:

1. Special design for various applications.
2. For efficient removal of rust, fouling and grease.
3. Convenient hole at the end of handle for hanging.
4. Metal wire bristles tackle tough cleaning jobs.



| Model | Description | Dimensions | Capacity | Color | Pack |
|-------|--------------------------------------|------------|----------|----------|------|
| 6761 | Stainless Steel Wire Brush | 26.0cm | N/A | YEL, BLA | 12 |
| 6764 | 30cm Wire Brush | 30.0cm | N/A | YEL, BLA | 12 |
| 6765 | Wire Brush with Scraper | 31.0cm | N/A | YEL, BLA | 12 |
| 6773 | 28cm Wire Brush | 28.0cm | N/A | YEL, BLA | 12 |
| 6783 | Tile and Grout Brush, Brass Bristles | 21.6cm | N/A | YEL | 12 |



COUNTER BRUSHES

PRODUCT FEATURES:

1. Perfect for quick clean-up of counters.
2. All-plastic structural foam handles ensure strength and durability.
3. Handle with hang-up hole for easy storage.
4. Bristles are available in Polypropylene, Tampico, and PET.



| Model | Description | Dimensions | Capacity | Color | Pack |
|-------|-----------------------------|------------|----------|----------|------|
| 6701 | Counter Brush, PET Fill | 30.0cm | N/A | YEL, BLA | 6 |
| 6702 | Counter Brush, PP Fill | 28.5cm | N/A | YEL, BLA | 6 |
| 6703 | Counter Brush, Tampico Fill | 38.5cm | N/A | YEL, BLA | 6 |
| 6704 | Counter Brush, PET Fill | 38.5cm | N/A | YEL, BLA | 6 |

PLASTIC HANDLE UTILITY BRUSHES

PRODUCT FEATURES:

1. Choice of long or short handles. Available Palmyra, Polypropylene and Tampico bristles.
2. All-plastic structural foam handles ensure strength and durability.
3. Handle with hang-up hole for easy storage.
4. Ideal for food service applications.



| Model | Description | Dimensions | Capacity | Color | Pack |
|-------|--|------------|----------|----------|------|
| 6712 | Short Plastic Handle Utility Brush, Palmyra Fill | 24.0cm | N/A | YEL, BLA | 6 |
| 6713 | Long Plastic Handle Utility Brush, Palmyra Fill | 52.0cm | N/A | YEL, BLA | 6 |
| 6722 | Short Plastic Handle Utility Brush, PP Fill | 24.0cm | N/A | YEL, BLA | 6 |
| 6723 | Long Plastic Handle Utility Brush, PP Fill | 52.0cm | N/A | YEL, BLA | 6 |
| 6732 | Short Plastic Handle Utility Brush, Tampico Fill | 24.0cm | N/A | YEL, BLA | 6 |
| 6733 | Long Plastic Handle Utility Brush, Tampico Fill | 52.0cm | N/A | YEL, BLA | 6 |



SCRUB BRUSHES

PRODUCT FEATURES:

1. Polypropylene and Tampico bristles in plastic block.
2. Designed for easier operation when scrubbing tile, floors, baseboards, walls and counter tops.

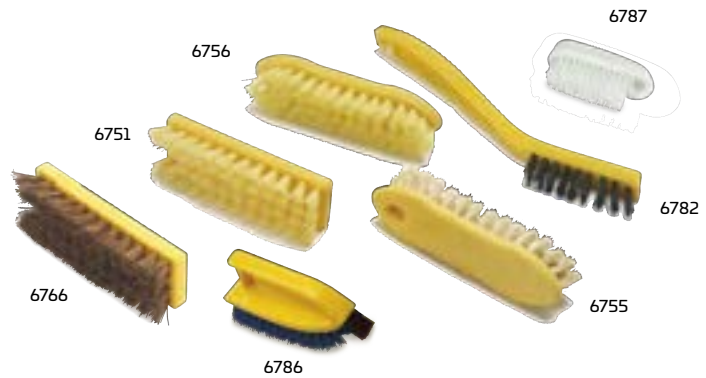

| Model | Description | Dimensions | Capacity | Color | Pack |
|-------|---|------------|----------|----------|------|
| 6751 | Square Block Scrub Brush, PP Fill | 18.5cm | N/A | YEL, BLA | 12 |
| 6755 | Pointed Scrub Brush, Tampico Fill | 21.5cm | N/A | YEL, BLA | 12 |
| 6756 | Pointed Scrub Brush, PP Fill | 21.5cm | N/A | YEL, BLA | 12 |
| 6766 | Square Block Scrub Brush, Palmyra Fill | 18.5cm | N/A | YEL, BLA | 12 |
| 6782 | Tile and Grout Brush, Nylon Fill | 22.0cm | N/A | YEL | 12 |
| 6786 | Iron Handle Scrub Brush, PP Fill | 17.0cm | N/A | YEL | 12 |
| 6787 | Plastic Hand and Nail Brush, Nylon Fill | 10.3cm | N/A | WHT | 12 |

WASH BRUSHES

PRODUCT FEATURES:

1. Plastic blocks resist splitting or delaminating to ensure durability and strength.
2. Available in multiple bristle types.
3. Handle is sold separately.



6752 has a built-in squeegee which is ideal for cleaning surface liquid



| Model | Description | Dimensions | Capacity | Color | Pack |
|-------|---|------------|----------|----------|------|
| 6743 | Deck Brush, Tampico and PP Fill | 23.0cm | N/A | YEL, BLA | 12 |
| 6746 | Deck Brush, PVC Fill | 27.5cm | N/A | YEL, BLA | 6 |
| 6747 | Wash Brush, Nylon Fill | 27.5cm | N/A | YEL, BLA | 6 |
| 6752 | Wash Brush with Squeegee, PP Fill | 61.0cm | N/A | YEL, BLA | 6 |
| 6753 | Floor Scrub, Plastic Block Tampico Fill | 23.0cm | N/A | YEL, BLA | 12 |
| 6754 | Wash Brush, Round Block, PP Fill | 26.0cm | N/A | YEL, BLA | 6 |
| 6784 | Deck Brush, Plastic Block, Tampico Fill | Dia 12.0cm | N/A | YEL, BLA | 12 |

BROOM HANDLES

PRODUCT FEATURES:

1. Available in threaded or tapered tips.
2. Handles with tapered tips are for use with push brooms.



| Model | Description | Dimensions | Capacity | Color | Pack |
|-------|---|---------------|----------|---------------------|------|
| 6350 | Steel Broom Handle, with Threaded Tip | 2.5 × 72.0cm | N/A | BLA | 12 |
| 6351 | Steel Broom Handle, with Threaded Tip | 2.2 × 124.0cm | N/A | BLUE, GRN, RED, YEL | 12 |
| 6352 | Wood Handle, Threaded | 2.4 × 137.0cm | N/A | LAC | 12 |
| 6353 | Wood Handle, Threaded | 2.4 × 152.0cm | N/A | LAC | 12 |
| 6362 | Wood Handle, Tapered | 2.9 × 137.0cm | N/A | LAC | 12 |
| 6363 | Wood Handle, Tapered | 2.9 × 152.0cm | N/A | LAC | 12 |
| 6388 | Wood Handle, Threaded Metal Tip | 2.4 × 152.0cm | N/A | LAC | 12 |
| 6389 | Steel Broom Handle, with Metal Threaded Tip | 2.5 × 150.0cm | N/A | BLA | 12 |



TOILET BRUSHES

PRODUCT FEATURES:

1. 6789 has a 15cm diameter head.
2. 30cm length heavy-duty round handle.
3. Funnel-shaped squeezing structure allows moving forward to squeeze without side leakage.
4. Holes on the tailend of handle are available for hanging and storage.
5. Polypropylene texturized filament brush wires offer excellent water absorption and stain removing capabilities; resist acid and alkaline; soft, and non-marking.



| Model | Description | Dimensions | Capacity | Color | Pack |
|-------|----------------------|---------------|----------|-------|------|
| 6788 | Toilet Brush | 30.0 × 12.0cm | N/A | WHT | 12 |
| 6789 | Tapered Toilet Brush | 30.0 × 12.0cm | N/A | WHT | 12 |
| 6790 | Bathtub Brush | 30.0 × 12.0cm | N/A | WHT | 12 |

TOILET BRUSH HOLDERS

PRODUCT FEATURES:

1. Provides a secure location for a spray bottle (6947).
2. Toilet bowl brush (6788) can be kept under the fliptop to contain the odors.
3. Compact structure, easy to carry.



6947/6785/6788

| Model | Description | Dimensions | Capacity | Color | Pack |
|-------|---------------------|----------------------|----------|--------------------------|------|
| 6785 | Toilet Brush Holder | 19.0 × 10.0 × 16.0cm | N/A | BLUE, GRN, RED, YEL, WHT | 6 |

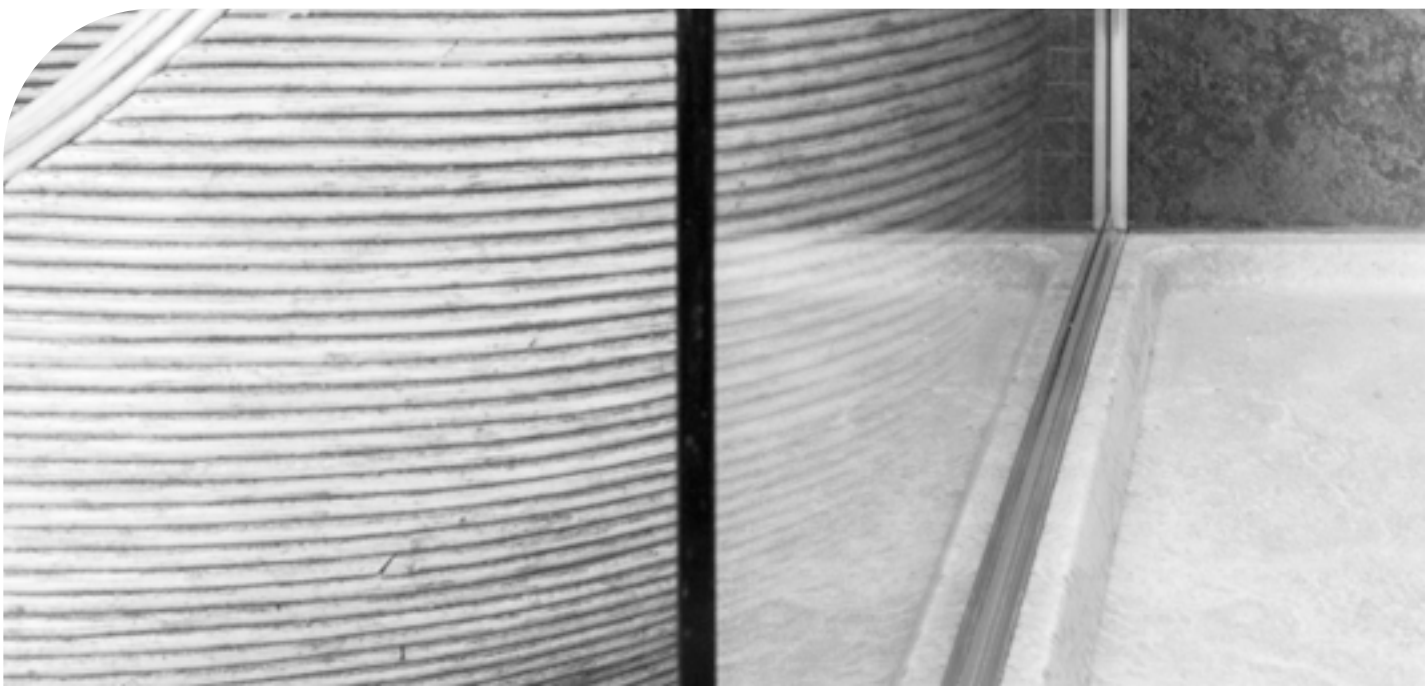

SCOURING PAD CLEANING SYSTEMS

PRODUCT FEATURES:

1. Designed to remove stains and dirt on various surfaces.
2. Made of heavy-duty galvanized sheets to add to sturdiness and durability.
3. Ergonomic handles offer a comfortable grip and easy operation.
4. The bracket and pad are easily dismantled. Worn out pads are replaceable.



| Model | Description | Dimensions | Capacity | Color | Pack |
|-------|----------------------------|---------------------|----------|-------|------|
| 6601 | Steel Scouring Pad Bracket | 14.5 × 10.0 × 6.3cm | N/A | BLUE | 12 |
| 6602 | Light Scouring Pad | 14.5 × 10.0 × 2.0cm | N/A | WHT | 12 |
| 6603 | Medium Scouring Pad | 14.5 × 10.0 × 2.0cm | N/A | BLUE | 12 |
| 6604 | Medium Scouring Pad | 14.5 × 10.0 × 2.0cm | N/A | BLA | 12 |

SCOURING PAD BRUSHES

PRODUCT FEATURES:

1. 6605 is an ideal tool to clean bathtubs, tiles, sinks, barrels and covers.
2. 6606 is an ideal tool to clean the floor, corner, and trace dirt.
3. 6607 high-performance cleaning particles coupled with premium fiber will effectively remove stains on porcelain floor, stone walls and floor.
4. Plastic scrapper assists in removing persistent and hard stains.



| Model | Description | Dimensions | Capacity | Color | Pack |
|-------|-------------------------------|--------------------|----------|-------|------|
| 6605 | Light Scouring Pad Brush | 15.0 × 9.0 × 7.0cm | N/A | WHT | 12 |
| 6606 | Medium Scouring Pad Brush | 15.0 × 9.0 × 7.0cm | N/A | BLUE | 12 |
| 6607 | Heavy-duty Scouring Pad Brush | 15.0 × 9.0 × 7.0cm | N/A | BLA | 12 |



CORN BROOMS

PRODUCT FEATURES:

1. Designed for rugged indoor/outdoor cleaning.
2. 100% natural broom corn fibers for long life and effective pick-up.
3. Removes fine dirt from even or rough surfaces.
4. Hand-selected, heavy-duty lacquered pine handles.



| Model | Description | Dimensions | Capacity | Color | Pack |
|-------|---|------------|----------|-------|------|
| 6801 | Corn Whisk Broom | 31.1cm | N/A | BLUE | 12 |
| 6802 | Lobby Broom, 100% Corn Fill | 21.0cm | N/A | RED | 12 |
| 6803 | Corn Broom, Standard, 2.5cm Stained/Lacquered Handle | 40.0cm | N/A | RED | 12 |
| 6804 | Corn Broom, Warehouse, 2.9cm Stained/Lacquered Handle | 34.0cm | N/A | RED | 12 |
| 6805 | Corn Broom, Warehouse, 2.9cm Stained/Lacquered Handle | 30.5cm | N/A | RED | 12 |

CONDENSER CLEANING BRUSHES

PRODUCT FEATURES:

1. Designed to clean rear and bottom area of various equipment such as refrigerators and air conditioning condenser.
2. Handle hole for hanging and storage.

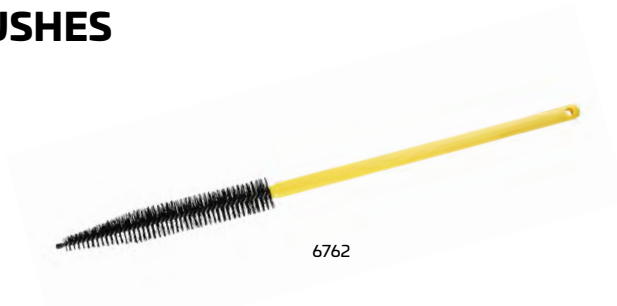

| Model | Description | Dimensions | Capacity | Color | Pack |
|-------|--------------------------|------------------|----------|-------|------|
| 6762 | Condenser Cleaning Brush | Dia 4.0 × 64.5cm | N/A | YEL | 12 |

DUSTING BRUSHES

PRODUCT FEATURES:

1. 6774 is suitable for cleaning the top and bottom of fans.
2. 6775 is suitable for cleaning high steps and platforms.
3. 6994 is suitable for cleaning spider webs from corners.
4. Use with NAELC® quick connect type handle to improve efficiency of cleaning.
5. Handle is sold separately.

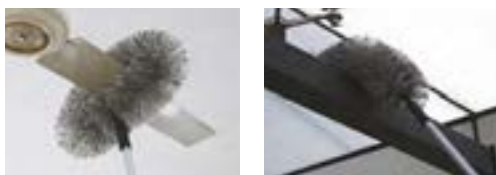

| Model | Description | Dimensions | Capacity | Color | Pack |
|-------|--------------------------|----------------------|----------|-------|------|
| 6774 | Fan Duster Brush | 41.0 × 31.0 × 15.0cm | N/A | BLA | 6 |
| 6775 | Dusting brush | 47.0 × 21.0 × 20.0cm | N/A | BLA | 6 |
| 6994 | Spider web dusting brush | Dia: 19.0 × 36.0cm | N/A | BLA | 12 |

SHOE BRUSHES

PRODUCT FEATURES:

1. Three-sided cleaning ensures optimized cleaning performance.
2. Heavy-duty steel structure offers strength and durability.
3. Heavy-duty PP brush wires help remove stains and soil easily.



6763



| Model | Description | Dimensions | Capacity | Color | Pack |
|-------|------------------------|----------------------|----------|-------|------|
| 6763 | Three-sided Shoe Brush | 50.0 x 30.0 x 19.5cm | N/A | BLA | 1 |

PIPE BRUSHES

PRODUCT FEATURES:

1. Designed to clean the surface of pipes.
2. A threaded hole is available on the tail to add a handle.
3. Handle is sold separately.



5711

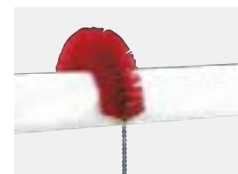

| Model | Description | Dimensions | Capacity | Color | Pack |
|-------|--------------------------------|------------|----------|--------------------------|------|
| 5711 | Hook-shaped Brush for Pipeline | 29.2cm | N/A | BLUE, GRN, RED, YEL, WHT | 12 |
| 5712 | Circular Brush for Pipeline | 30.5cm | N/A | BLUE, GRN, RED, YEL, WHT | 12 |

CLEANING BRUSHES FOR PIPES

PRODUCT FEATURES:

1. Designed to clean pipes of various sizes.
2. Material in compliance with FDA requirements.
3. Hole on the tailend of handle for hanging and storage.
4. Select a suitable brush according to the pipe diameter and length.

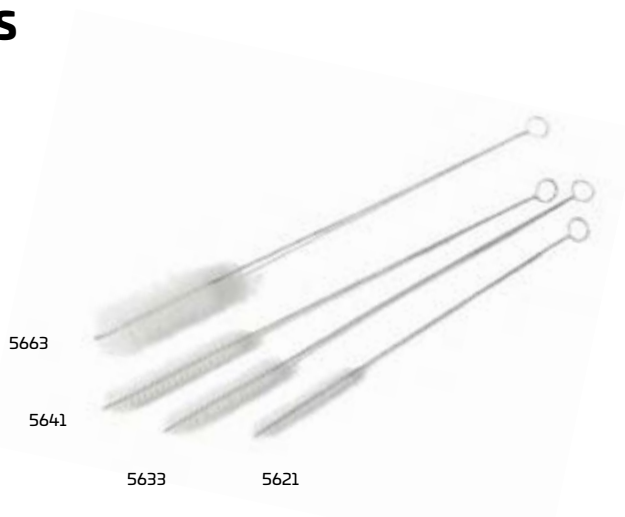

5663

5641

5633

5621

| Model | Description | DIA | Dimensions | Color | Pack |
|-------|-----------------------------|-------|------------|-------|------|
| 5621 | Cleaning Brush for Pipeline | 1.0cm | 30.5cm | WHT | 12 |
| 5633 | Cleaning Brush for Pipeline | 1.3cm | 61.0cm | WHT | 12 |
| 5641 | Cleaning Brush for Pipeline | 1.6cm | 45.7cm | WHT | 12 |
| 5652 | Cleaning Brush for Pipeline | 1.9cm | 61.0cm | WHT | 12 |
| 5663 | Cleaning Brush for Pipeline | 2.5cm | 61.0cm | WHT | 12 |
| 5672 | Cleaning Brush for Pipeline | 3.8cm | 91.4cm | WHT | 12 |
| 5683 | Cleaning Brush for Pipeline | 5.1cm | 61.0cm | WHT | 12 |

DUST PANS



PREDATOR® UPRIGHT DUST PANS

PRODUCT FEATURES:

1. Stylish appearance and an innovative design.
2. Fit for applications such as a mall, canteen or lobby.
3. Durable rear wheels improve wear resistance and extend product life.
4. Patent pending self-opening and closing lid conceals unsightly dirt and debris.
5. Bracket for storage of Lobby Broom (6621) is available on the handle.



Using the 6915 Upright Dust Pan Hanger Bracket



| Model | Description | Dimensions | Capacity | Color | Pack |
|-------|--|----------------------|----------|-------|------|
| 6911 | PREDATOR® Upright Dust Pan with Hook | 32.3 × 13.9 × 95.8cm | N/A | BLA | 6 |
| 6912 | PREDATOR® Upright Dust Pan with Cover and Hook | 33.2 × 14.4 × 95.8cm | N/A | BLA | 6 |
| 6913 | PREDATOR® Upright Dust Pan with Cover without Hook | 33.2 × 14.4 × 95.8cm | N/A | BLA | 6 |
| 6914 | PREDATOR® Upright Dust Pan without Cover and Hook | 32.2 × 13.9 × 95.8cm | N/A | BLA | 6 |
| 6915 | PREDATOR® Upright Dust Pan Hanger Bracket | 10.6 × 4.9 × 3.7cm | N/A | BLA | 6 |

PREDATOR® DRY/WET DUST PAN

PRODUCT FEATURES:

1. Allows dry/wet spills to be swept away quickly and safely.
2. 6916 holds up to 2L liquid or solid debris for efficient clean up.
3. Easy to clean smooth surface.
4. Soft double-layer microporous foam rubber blade cleans well even on uneven surfaces.



| Model | Description | Dimensions | Capacity | Color | Pack |
|-------|----------------------------------|-----------------------|----------|-------|------|
| 6916 | PREDATOR® Dry/Wet Dust Pan | 44.3 × 27.2 × 111.6cm | 2L | BLA | 4 |
| 6917 | PREDATOR® Dry/Wet Floor Squeegee | 34.3 × 4.8 × 127.0cm | N/A | BLA | 4 |

DUST PANS

PRODUCT FEATURES:

1. Picks up dirt and debris quickly.
2. Durable plastic structure prolongs service life.
3. Available in Extra Large & Jumbo sizes to hold more dirt and debris.
4. 6927, 6928 integrated steel heavy-duty dust pans, suitable for cleaning metal scrap and other hard objects.



| Model | Description | Dimensions | Capacity | Color | Pack |
|-------|---------------------------------------|----------------------|----------|-------|------|
| 6923 | Heavy-duty Dust Pan | 31.1 × 21.0 × 6.7cm | N/A | BLA | 12 |
| 6924 | Extra Large Dust Pan | 40.6 × 37.5 × 13.7cm | N/A | BLA | 6 |
| 6925 | Jumbo Dust Pan | 55.9 × 45.7 × 19.7cm | N/A | BLA | 6 |
| 6926 | Heavy-duty Dust Pan and Counter Brush | 31.1 × 21.0 × 6.7cm | N/A | BLA | 6 |
| 6927 | Steel Heavy-duty Dust Pan | 30.5 × 34.5 × 7.5cm | N/A | BLA | 6 |
| 6928 | Steel Heavy-duty Dust Pan | 40.0 × 36.5 × 12.5cm | N/A | BLA | 6 |

STEP&SWEEP DUST PANS

PRODUCT FEATURES:

1. Wide mouth dust pan ideal for indoor and outdoor clean-ups.
2. Step-on design helps to hold the dust pan on the ground without bending.
3. Soft rubber leading edge for efficient surface contact.
4. Ergonomic, soft rubber handle, comfortable and convenient.
5. Hole on the tail-end of handle for hanging and storage.



6929



Step-on design helps fixing the dust pans to the ground without bending

| Model | Description | Dimensions | Capacity | Color | Pack |
|-------|---------------------|----------------------|----------|-------|------|
| 6929 | Step&Sweep Dust Pan | 37.0 × 33.0 × 12.5cm | N/A | GRAY | 6 |

FLOOR SQUEEGEES



TRADITIONAL FLOOR SQUEEGEES

PRODUCT FEATURES:

1. Galvanized metal frame and locking strip.
2. Fits 6362, 6363 wood broom handles which are sold separately.
3. For removing liquids and heavy dirt.



| Model | Description | Dimensions | Capacity | Color | Pack |
|-------|--------------------------------|----------------------|----------|-------|------|
| 6814 | 46.0cm Straight Floor Squeegee | 45.7 × 10.2 × 17.3cm | N/A | BLA | 6 |
| 6815 | 61.0cm Straight Floor Squeegee | 61.0 × 10.2 × 17.3cm | N/A | BLA | 6 |
| 6816 | 91.0cm Straight Floor Squeegee | 91.4 × 10.2 × 17.3cm | N/A | BLA | 6 |
| 6817 | 46.0cm Replacement Blade | 45.7 × 0.6 × 5.1cm | N/A | BLA | 6 |
| 6818 | 61.0cm Replacement Blade | 61.0 × 0.6 × 5.1cm | N/A | BLA | 6 |
| 6819 | 91.0cm Replacement Blade | 91.4 × 0.6 × 5.1cm | N/A | BLA | 6 |
| 6825 | 61.0cm Curved Floor Squeegee | 59.7 × 10.2 × 17.3cm | N/A | BLA | 6 |

DUAL MOSS SQUEEGEES

PRODUCT FEATURES:

1. Non-marking, flexible blades are ideal for uneven surfaces.
2. Leaves floors virtually dry to the touch, ideal for spills.
3. Handles are sold separately.



| Model | Description | Dimensions | Capacity | Color | Pack |
|-------|----------------------------------|---------------------|----------|-------|------|
| 6841 | 46.0cm Standard Floor Squeegee | 45.7 × 7.6 × 11.4cm | N/A | BLA | 10 |
| 6842 | 56.0cm Standard Floor Squeegee | 55.9 × 7.6 × 11.4cm | N/A | BLA | 10 |
| 6843 | 56.0cm Heavy-duty Floor Squeegee | 55.9 × 8.3 × 14.0cm | N/A | BLA | 10 |
| 6844 | 76.0cm Heavy-duty Floor Squeegee | 76.2 × 8.3 × 14.0cm | N/A | BLA | 10 |

PROFESSIONAL PLASTIC SQUEEGES



PRODUCT FEATURES:

1. Pre-treated polypropylene resists corrosion.
2. Twin black porous foam blades.
3. For removing liquids, moderate dirt.
4. Rubber resists oils, greases and most chemicals.
5. Fits 6351 broom handle which is sold separately.



6831

| Model | Description | Dimensions | Capacity | Color | Pack |
|-------|--|--------------------|----------|---------------------|------|
| 6831 | 46.0cm Plastic Professional Squeegee with Black Dual Moss Rubber | 45.7 x 5.8 x 8.9cm | N/A | BLUE, GRN, RED, YEL | 10 |



DUSTING TOOLS



LAMBSWOOL DUSTERS

PRODUCT FEATURES:

1. 100% lambs wool duster.
2. Ideal for dusting large areas quickly and effectively.



6987

| Model | Description | Dimensions | Capacity | Color | Pack |
|-------|--|------------|----------|-------|------|
| 6987 | 76.0-100.0cmLambswool Duster with Telescoping Plastic Handle | N/A | N/A | GRAY | 6 |

OSTRICH DUSTERS

PRODUCT FEATURES:

1. Ideal for offices, malls, schools etc.
2. South African ostrich feathers are delicate, pliable, anti-static and with good dusting capability.
3. Handle with hang-up hole for easy storage.



6995

| Model | Description | Dimensions | Capacity | Color | Pack |
|-------|---------------------|------------|----------|-------|------|
| 6995 | 35cm Ostrich Duster | N/A | N/A | LAC | 12 |

OVERHEAD DUSTING TOOL WITH FLEXIBLE HEAD

PRODUCT FEATURES:

1. For difficult overhead dusting.
2. Flexible head adjusts to match virtually any shape .
3. The washable dust mitt can be worn on the hand or used with the flexible head dusting tool.
4. Dusting Tool and Dust Mitt are available.



6988

| Model | Description | Dimensions | Capacity | Color | Pack |
|-------|--|------------|----------|-------|------|
| 6988 | Overhead Dusting Tool with Flexible Head, Flexible Head with 152.0cm Aluminum Handle | N/A | N/A | MSILV | 6 |
| 6989 | Dust Mitt Off-floor Tool, Cotton | N/A | N/A | WHT | 12 |

OVERHEAD DUSTING TOOLS

PRODUCT FEATURES:

1. For difficult overhead dusting.
2. Flexible head adjusts to match virtually any shape.
3. The washable dust mitt can be worn on the hand or used with the flexible head dusting tool.
4. Dusting Tool and Dust Mitt are available.



| Model | Description | Dimensions | Capacity | Color | Pack |
|-------|---|------------|----------|-------|------|
| 6990 | Overhead Dusting Tool with Washable Head, 130.0cm Extension Handle | N/A | N/A | GRAY | 12 |
| 6991 | Overhead Dusting Tool with Angled Washable Head, 130.0cm Extension Handle | N/A | N/A | GRAY | 12 |
| 6992 | Overhead Dusting Tool with Washable Head, 260.0cm Extension Handle | N/A | N/A | GRAY | 12 |
| 6993 | Overhead Dusting Tool Replacement Head, Fits 6990/6991/6992 | N/A | N/A | WHT | 12 |

WALL WASHER KITS

PRODUCT FEATURES:

1. Pivoting head for smooth, even control.
2. Washable brushes can be changed easily.
3. Quick-Connector for replacing easily and quickly.
4. Handles (6411/6412/6413/6414) need to be purchased separately.



6901/6411

| Model | Description | Dimensions | Capacity | Color | Pack |
|-------|--|---------------------|----------|-------|------|
| 6901 | Wall Washer Kit Includes 2 Brushes | 20.0 x 9.5 x 17.0cm | N/A | BLA | 2 |
| 6902 | Wall Washer Kit Includes 2 Microfiber Brushes | 20.0 x 9.5 x 17.0cm | N/A | BLA | 2 |
| 6903 | Wall Washer Kit Replacement Brushes | 23.0 x 12.7cm | N/A | WHT | 12 |
| 6904 | Wall Washer Kit Replacement Microfiber Brushes | 23.0 x 12.7cm | N/A | WHT | 12 |





CLEANING TOOL HOLDERS



PRODUCT FEATURES:

1. Helps increase productivity and efficiency through better tool storage and access.
2. S-hooks hold 1.6cm to 3.2cm handle diameters.
3. Special hooks afford easy accessibility.
4. Clip for holding a record book.
5. 25113, 25114 and 25115 aluminum alloy material, light and rust-proof. Used with stuck clips, hooks and signboards.
6. 25116 is suitable for holding handles with a diameter of 22-32mm.
7. 25117 is suitable for holding handles with a diameter of 28-38mm.
8. 25118 is suitable for holding cleaning tools with hanging holes.
9. 25119 can be used with the base of the aluminum alloy tool rack, which enables clear identification of the hung tools at each position.



6942



6941



25114/25117/25116/25118/25119



| Model | Description | Dimensions | Capacity | Color | Pack |
|-------|--|---------------------|----------|----------------------|------|
| 6941 | Closet Organizer/Tool Holder Kit | 45.7 × 8.3 × 10.8cm | N/A | BLUE, GRN, RED, YEL | 6 |
| 6942 | Closet Organizer/Tool Holder Kit | 86.4 × 8.3 × 10.8cm | N/A | BLUE, GRN, RED, YEL | 4 |
| 25113 | HEDGEHOG® Cleaning Tool Rack Base, 300mm | 30.0 × 5.0 × 1.0cm | N/A | BLUE, VGRN, RED, GLD | 12 |
| 25114 | HEDGEHOG® Cleaning Tool Rack Base, 500mm | 50.0 × 5.0 × 1.0cm | N/A | BLUE, VGRN, RED, GLD | 12 |
| 25115 | HEDGEHOG® Cleaning Tool Rack Base, 900mm | 90.0 × 5.0 × 1.0cm | N/A | BLUE, VGRN, RED, GLD | 12 |
| 25116 | HEDGEHOG® Small Stuck Clip | 8.0 × 8.0 × 3.6cm | N/A | BLUE, VGRN, RED, GLD | 12 |
| 25117 | HEDGEHOG® Large Stuck Clip | 8.5 × 8.0 × 3.6cm | N/A | BLUE, VGRN, RED, GLD | 12 |
| 25118 | HEDGEHOG® Hook | 4.0 × 4.4 × 3.3cm | N/A | BLUE, VGRN, RED, GLD | 12 |
| 25119 | HEDGEHOG® Signboard | 11.2 × 12.5 × 0.9cm | N/A | BLUE, VGRN, RED, GLD | 12 |

IRONING ORGANIZERS

PRODUCT FEATURES:

1. An ideal solution for placing a hot iron.
2. Installs easily, virtually anywhere.
3. Efficiently stores iron with ironing board for convenience.
4. Ultimate heat resistant plastic construction.
5. Aesthetic design complements guest room decor.



6951

| Model | Description | Dimensions | Capacity | Color | Pack |
|-------|-------------------|---------------|----------|----------|------|
| 6951 | Ironing Organizer | 13.3 × 29.4cm | N/A | BLA, WHT | 6 |

COMMERCIAL CLEANING AND MAINTENANCE GLOVES

PRODUCT FEATURES:

1. Designed for harsh applications and rough materials.
2. Non-skid Neoprene is available at the finger tip to ensure a non-slip grip.
3. Breathable stretch materials add to comfort.
4. Designed with elastic materials at the palm to reduce shock.



6983



Designed with elastic materials at the palm to reduce shock

| Model | Description | Dimensions | Capacity | Color | Pack |
|-------|-------------------------------|---------------|----------|-------|------|
| 6983 | Heavy-duty Glove, Large | 24.5 × 11.4cm | N/A | BLA | 6 |
| 6984 | Heavy-duty Glove, Extra Large | 24.5 × 11.8cm | N/A | BLA | 6 |

PROFESSIONAL KNEEPADS

PRODUCT FEATURES:

1. Non-marking cap protects surfaces.
2. Non-skid cap helps to avoid slipping.
3. Breathable perforated Neoprene materials.
4. Notched for comfort when standing.
5. One-strap sizing plus opening for ventilation.



6985



Professional kneepad can protect your knees from harm

| Model | Description | Dimensions | Capacity | Color | Pack |
|-------|-----------------------|----------------------|----------|-------|------|
| 6985 | Professional Kneepads | 22.9 × 17.8 × 10.8cm | N/A | BLA | 6 |

FOLDING STEPSTOOLS

PRODUCT FEATURES:

1. Slip resistant surfaces on steps and foot pads.
2. Easy to transport and space efficient with folded size only 15.9cm.
3. Plastic web-structure molded, supports loads up to 150 kg.
4. Easy to clean and resistant to other damage.
5. Meeting the standards of EN 14183:2003.



6932



Easy to transport

| Model | Description | Dimensions | Load | Color | Pack |
|-------|----------------------------|--|--------|------------------|------|
| 6932 | Two-step Folding Stepstool | Open: 47.5 × 51.5 × 59.0cm Closed: 47.5 × 15.9 × 65.0cm | 150 kg | GRAY, DGRAY, BLA | 3 |

MOVABLE STEPSTOOL

PRODUCT FEATURES:

1. Compression casters for easy mobility.
2. Supports loads up to 160 kg.
3. The two steps are equipped with a soft non-slip pad.
4. The casters will automatically retract when weight is applied.
5. Heavy-duty plastic structure, solid and durable, and will not damage walls or furniture.
6. Meets standards EN14183:2003.



6933



Compression casters for easy mobility

| Model | Description | Dimensions | Load | Color | Pack |
|-------|----------------------------|---------------|--------|-----------|------|
| 6933 | Movable Two-step Stepstool | 40.6 × 34.3cm | 160 kg | BLA, BEIG | 1 |

ROTOMOLDED PLASTIC PEDALS

PRODUCT FEATURES:

1. Rotomolded; industrial-grade; sturdy and durable.
2. One-piece body construction provides superior strength and durability.
3. The two pedals are equipped with a soft non-slip pad.
4. Bearing up to 160 kg.
5. Rubber pad at the bottom with anti-skid function, increase security.
6. Four direction pedal design, easy to use.
7. Meeting the standards of EN 14183:2003.



6930

| Model | Description | Dimensions | Load | Color | Pack |
|-------|--------------------------|----------------------|--------|----------|------|
| 6930 | Rotomolded Plastic Pedal | 49.0 × 49.0 × 36.4cm | 160 kg | YEL, BLA | 1 |

MULTI-FUNCTION LADDERS

PRODUCT FEATURES:

1. Complies with the requirements of ANSI 14.2, AS/NZS 1892.1 and EN-131.
2. Patented auto-locking hinge design.
3. Triple modes of A-shaped ladder, straight ladder and extension ladder.
4. Made from premium quality lightweight aluminum, with outstanding strength and durability.
5. Non-slip step design for added safety.
6. Reliable soft tips feet.
7. Can be folded down to save space and transportation costs.
8. Extends up to four times folded height.



6945 Schematic Work Status

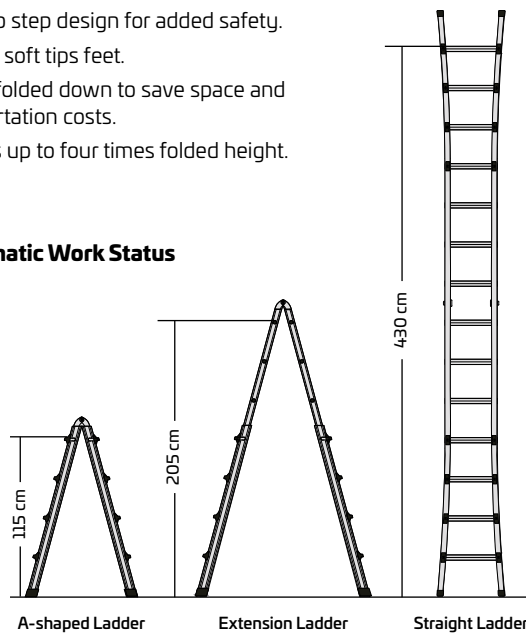

Can be quickly converted into a **straight ladder**, high operating convenience



Can be **used on the stairs**, safe and reliable

| Model | Description | Dimensions | Extension Length | Folding Length | Load | Color | Pack |
|-------|-----------------------|-----------------------|------------------|----------------|--------|-------|------|
| 6945 | Multi-function Ladder | 131.0 × 60.5 × 20.0cm | 452.0cm | 220.0cm | 150 kg | MSILV | 1 |
| 6946 | Multi-function Ladder | 198.0 × 75.0 × 20.0cm | 686.0cm | 334.0cm | 150 kg | MSILV | 1 |



FOLDING LADDERS

PRODUCT FEATURES:

1. Made from premium quality lightweight aluminum, with outstanding strength and durability.
2. Can be folded down easily and quickly, compactable for space saving.
3. Non-slip step design for safety.
4. Reliable soft tips feet.



| Model | Description | Dimensions | Load | Color | Pack |
|-------|---------------------------|--|--------|-------|------|
| 6943 | Two-step Folding Ladder | Open: 46.0 × 47.0 × 92.0cm Closed: 46.0 × 15.2 × 98.5cm | 120 kg | BLA | 1 |
| 6944 | Three-step Folding Ladder | Open: 51.0 × 63.5 × 116.0cm Closed: 51.0 × 15.2 × 123.5cm | 120 kg | BLA | 1 |

DELUXE CARRY CADDIES

PRODUCT FEATURES:

1. Perfect for carrying tools and cleaning supplies.
2. Conveniently fits on cleaning and housekeeping carts.
3. User friendly handles fit your hand and allow for a comfortable grip.
4. Securely holds spray bottle (6935) and other common cleaning tools.
5. Allows for stable stacking to save space.
6. Rounded corners ensure safety and prevent injury.
7. Innovative design, double-layer toolbox (6955) can carry more cleaning supplies at once to improve work efficiency.
8. 6955 used with 6956 to locate toilet brush.



6931



6956



6955



6955 used with 6956 to locate toilet brush

| Model | Description | Dimensions | Capacity | Color | Pack |
|-------|------------------------------|----------------------|----------|-------|------|
| 6931 | Deluxe Carry Caddy | 38.6 × 28.0 × 17.0cm | N/A | BLA | 6 |
| 6955 | Double-layer Tool Basket | 38.4 × 26.5 × 28.8cm | N/A | BLA | 3 |
| 6956 | Toilet Brush Holder for 6955 | 10.3 × 9.0 × 9.1cm | N/A | BLA | 6 |

NOZZLE AND SPRAY BOTTLES



PRODUCT FEATURES:

1. Easier and more efficient for a variety of cleaning jobs.
2. Adjustable nozzle, spray distance up to 75cm.
3. High-capacity up to 3ml.
4. Sturdy HDPE spray bottle won't be damaged even in case of collision or falling thanks to its excellent strength and toughness.
5. Ergonomic grip-type nozzle offers a comfortable hold and easy operation.



| Model | Description | Dimensions | Capacity | Color | Pack |
|-------|---------------------------|---------------------|----------|--------------------------|------|
| 6934 | Nozzle | 12.5 x 3.3 x 34.0cm | N/A | BLUE, GRN, RED, YEL, WHT | 12 |
| 6935 | 950ml Spray Bottle | 8.9 x 25.0cm | N/A | WHT | 12 |
| 6947 | Spray Bottle with Trigger | 12.5 x 8.5 x 34.0cm | N/A | RED | 12 |
| 6952 | 650ml Spray Bottle | 8.9 x 20.0cm | N/A | WHT | 12 |

PNEUMATIC SPRAYERS

PRODUCT FEATURES:

1. Suitable for a variety of cleaning jobs.
2. Sturdy and durable structure.
3. Adjustable nozzle for spraying mist or water droplets.



| Model | Description | Dimensions | Capacity | Color | Pack |
|-------|-------------------|------------|----------|-------|------|
| 6936 | Pneumatic Sprayer | N/A | 1.0L | WHT | 12 |
| 6937 | Pneumatic Sprayer | N/A | 1.5L | WHT | 12 |
| 6938 | Pneumatic Sprayer | N/A | 2.0L | WHT | 12 |



NIPPERS

PRODUCT FEATURES:

1. Safely collects syringes, sharp objects and general waste.
2. User-friendly handle provides comfortable and easy maneuverability.
3. Clamp made of soft materials to enable an easy pick-up of objects.



6997

| Model | Description | Dimensions | Capacity | Color | Pack |
|-------|-------------|------------|----------|-------|------|
| 6996 | Nipper | 45.0cm | N/A | BLA | 12 |
| 6997 | Nipper | 84.0cm | N/A | BLA | 12 |

TOILET PUMPS

PRODUCT FEATURES:

1. Head made of rubber suitable for unblocking toilets and sewers.
2. Produces high pressure for unblocking.
3. Handle hole for hanging and storage.



6939

6940

| Model | Description | Dimensions | Capacity | Color | Pack |
|-------|-------------|---------------|----------|-------|------|
| 6939 | Toilet Pump | 14.0 × 50.5cm | N/A | BLA | 12 |
| 6940 | Toilet Pump | 14.5 × 51.5cm | N/A | BLA | 12 |

SCRAPERS

PRODUCT FEATURES:

1. Heat treated carbon steel blade for maximum strength.
2. Polished blade treated with a clear coat protectant against corrosion.
3. Contoured handle helps reduce effort.
4. Non-slip elastic handle offers a comfortable hold.



6981

6982

| Model | Description | Dimensions | Capacity | Color | Pack |
|-------|---------------|--------------------|----------|-------|------|
| 6981 | 8.0cm Scraper | 21.3 × 7.6 × 2.4cm | N/A | BLA | 6 |
| 6982 | 4.0cm Scraper | 20.3 × 4.0 × 2.4cm | N/A | BLA | 6 |





HEIMDALL® BABY CHANGING STATIONS



PRODUCT FEATURES:

1. Wide table is equipped with adjustable seat belts enhancing safety and reliability.
2. All plastic web structure ensures strength and durability.
3. Die cast molding is convenient for hanging accessories.
4. Storage units at the top of the table are convenient to place baby care products.
5. Closed width is only 10.2cm, saving space.
6. Table is equipped with handle, convenient to open.
7. Built-in shelf and liner storage.
8. Antibacterial technology can inhibit bacteria growth and odor effectively.
9. Meeting the standards of ASTM F2285 and EN 12221-1.



8021



8023



MICROBAN® ANTI-BACTERIA PROTECTION TECHNOLOGIES

1. Microban® anti-bacteria technologies provide full protection and resist odor and stain due to bacteria.
2. Microban® anti-bacteria ingredients have been added to the baby changing station during its production for permanent protection.



Plastic sample without Microban® anti-bacteria ingredients.



Plastic sample with Microban® anti-bacteria ingredients.

*Microban® is the registered owner of Microban® trademark, and reserves all the rights. Microban® anti-microbial protection is not designed to protect users against disease causing micro-organisms and is not a substitute for routine cleaning.



Die cast molding is convenient for hanging accessories. Storage units at the top of the table are convenient for placing baby care products

| Model | Description | Dimensions | Color | Pack |
|-------|--|------------------------------|-------|------|
| 8021 | HEIMDALL® Baby Changing Station | Closed: 84.5 × 54.6 × 10.2cm | LPLAT | 1 |
| 8022 | Protective Liners For Baby Changing Station (20 Units) | 32.5 × 44.5cm | WHT | 16 |
| 8023 | HEIMDALL® Baby Changing Station | Closed: 58.4 × 86.6 × 10.2cm | LPLAT | 1 |

KID&COOL® MICROBAN® INFANT SAFETY SEATS



PRODUCT FEATURES:

1. All plastic web structure ensures strength and durability.
2. Strap type safety belt for effective protection.
3. Closed width is only 13.0cm, saving space.
4. Smooth surface for easy cleaning.
5. Antibacterial technology can inhibit bacteria growth and odor effectively.
6. Meeting the standards of ASTM F2613 and EN 12520.



8031

| Model | Description | Dimensions | Color | Pack |
|-------|--|------------------------------|-------|------|
| 8031 | KID&COOL® Microban® Infant Safety Seat | Closed: 35.5 × 13.0 × 48.6cm | LPLAT | 1 |



WALL-MOUNTED SANITARY NAPKIN RECEPTACLES

PRODUCT FEATURES:

1. Saves space, easy to use.
2. Tightly-sealed cover prevents odors spreading.
3. Detachable stiff liner is easy to clean and maintain.
4. Smooth surface for easy cleaning.
5. Five waxed bags are included for easy collection of waste and to maintain clean inner walls.



6950

| Model | Description | Dimensions | Capacity | Color | Pack |
|-------|---|----------------------|----------|-------|------|
| 6950 | Wall-mounted Sanitary Napkin Receptacle | 27.3 × 13.3 × 31.8cm | N/A | WHT | 1 |
| 6998 | Waxed Bag (50 per bundle) | 22.2 × 21.6cm | N/A | N/A | 5 |

FEMININE SANITARY BINS

PRODUCT FEATURES:

1. The safe, sanitary solution for handling personal waste.
2. Smooth surfaces are easy to clean and avoid hidden dirt and bacteria.
3. Pedal operation avoids direct contact.
4. Deep grooves prevent sanitary napkins from adhering to bin walls.
5. Lined interior for stain prevention.



6949

6948



| Model | Description | Dimensions | Capacity | Color | Pack |
|-------|--|----------------------|----------|-----------|------|
| 6948 | Pedal Sanitary Bin | 42.3 × 15.5 × 49.0cm | 11L | GRAY, WHT | 1 |
| 6949 | Pedal Sanitary Bin | 48.2 × 15.5 × 53.9cm | 19L | GRAY, WHT | 4 |
| 6966 | Bin Liner Refills (15 Pieces Per Roll), for 6948 | N/A | N/A | N/A | 12 |
| 6967 | Bin Liner Refills (15 Pieces Per Roll), for 6949 | N/A | N/A | N/A | 12 |

BATH MATS

PRODUCT FEATURES:

1. Does not contain natural rubber latex, which may cause allergic reactions.
2. Perfect for shower stall or bathtub.
3. Suction-backed to stay firmly in place.
4. Textured surface prevents slippage.
5. Products containing antibacterial agents, inhibiting the growth of bacteria, mildew resistant.



6961

6963

| Model | Description | Dimensions | Capacity | Color | Pack |
|-------|-------------|---------------|----------|-----------|------|
| 6961 | Bath Mat | 57.2 × 35.6cm | N/A | BEIG, WHT | 4 |
| 6963 | Bath Mat | 71.1 × 40.6cm | N/A | BEIG, WHT | 4 |
| 6965 | Bath Mat | 91.4 × 45.7cm | N/A | BEIG, WHT | 4 |





MOBILE WORK CENTERS

| | |
|-----------------------------|-----|
| Bitbar® Mobile Work Centers | 146 |
| Bitbar® Utility Carts | 147 |
| Bitbar® Flat-shelf Carts | 147 |
| Ladder Carts | 148 |
| Material Supply Carts | 149 |
| Casters Selection Guide | 150 |
| Casters Performance Guide | 150 |

PLATFORM TRUCKS

| | |
|------------------------------------|-----|
| Oeasy® Platform Trucks | 152 |
| Oeasy® A-Frame Panel Trucks | 153 |
| Oeasy® Sheet & Panel Trucks | 153 |
| Oeasy® Work Height Platform Trucks | 154 |
| Oeasy® Stanchion Platform Trucks | 155 |
| Oeasy® Skid Platform Trucks | 155 |
| Oeasy® Panel Platform Trucks | 156 |
| Utility Trolleys | 156 |
| Totes Trolleys | 157 |

CUBE TRUCKS

| | |
|-------------|-----|
| Cube Trucks | 158 |
|-------------|-----|

TILT TRUCKS

| | |
|-------------------------------------|-----|
| Rotomolded Tilt Trucks | 160 |
| Heavy-duty Towable Tilt Trucks | 160 |
| Heavy-duty Forkliftable Tilt Trucks | 161 |
| Structural Foam Tilt Trucks | 161 |
| Tilt Truck Covers | 162 |
| Collapsible Linen Carts | 162 |
| Cover | 162 |

UTILITY SERVICE CARTS

| | |
|----------------------------------|-----|
| Hi5® Utility Service Carts | 164 |
| Hi5® Folding Service Carts | 166 |
| Accessories | 167 |
| Utility Service cart Accessories | 167 |
| Compatibility Guide | 168 |

STORAGE AND ORGANIZATION

| | |
|----------------------------|-----|
| Shelving Systems | 170 |
| Bitbar® Tool Boxes | 171 |
| Thor® Large Totes with Lid | 171 |
| Thor® Stackable Tote Bins | 172 |
| Multi-function Ladders | 173 |
| Folding Ladders | 173 |
| Folding Stepstools | 174 |
| Movable Pedals | 174 |
| Rotomolded Plastic Pedals | 174 |
| Storage Pallets | 175 |
| Goods Shelves | 175 |

CONTAINER TOOLS

| | |
|----------------------------|-----|
| Nestable Pallets | 176 |
| Shelf Pallets | 177 |
| Stacking Pallets | 177 |
| Heavy-load Bulk Containers | 178 |



Innovative Designs

TRUST platform trucks and utility carts deliver transport solutions to meet the demands of every environment.

Robust construction resists distortion, dents, breakage, rust and decay

Tough, resilient surface absorbs impact and provides quiet operation. Virtually maintenance-free; resistant to most chemicals, impervious to water damage, and can be easily cleaned.



Conventional metal trolleys are susceptible to dents and rust.



Conventional wooden trolleys are susceptible to splinters and rot

Transport Materials Effectively and Safely

The handle on the cart is adjustable to fit your height and reduce muscle strain.

Casters meet exacting demands

Casters are optimized for each product through repeated testing to provide the most effective and durable material transport solutions.



Polyolefin

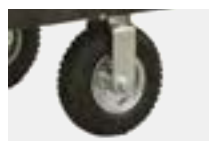

Pneumatic



Thermoplastic Rubber

MOBILE WORK CENTERS



BITBAR® MOBILE WORK CENTERS



PRODUCT FEATURES:

1. Innovative design for easy transportation of any item.
2. Sturdy structural foam construction won't rust, dent, chip, or peel.
3. Molded-in storage compartments and cup holder are suitable for storage of small items and tools.
4. User friendly handles provide comfortable and easy maneuverability.
5. 12.5cm non-marking casters (two fixed and two swivel with full braking mechanism) ensure easy maneuverability.
6. Full extension metal drawers with ball bearing slides are available.



4031

4033



The top has open-side to enable convenient use



The grooves on the top prevent small items against rolling out



Lockable storage compartment helps keep contents secure



Sturdy aprons up to 67mm height prevent items against rolling out



Doors open up to 270° provide easy access to content

| Model | Description | Dimensions | Load | Color | Pack |
|-------|--|-----------------------|-------|-------|------|
| 4031 | BITBAR® Mobile Work Center with 4-drawer and Cabinet | 124.5 × 67.0 × 97.2cm | 340kg | BLA | 1 |
| 4032 | BITBAR® Mobile Work Center with 2-door Cabinet | 124.5 × 67.0 × 97.2cm | 340kg | BLA | 1 |
| 4033 | BITBAR® Mobile Work Center with 8-drawer | 124.5 × 67.0 × 97.2cm | 340kg | BLA | 1 |

BITBAR® UTILITY CARTS



PRODUCT FEATURES:

1. Innovative design for easy transportation of any item.
2. Sturdy structural foam construction won't rust, dent, chip, or peel.
3. Molded-in storage compartments and cup holder - suitable for storage of small items and tools.
4. User friendly handles provide comfortable and easy maneuverability.
5. Integrated molded grooves for inserting steel tube or metal reeled coils or other coil-like items.

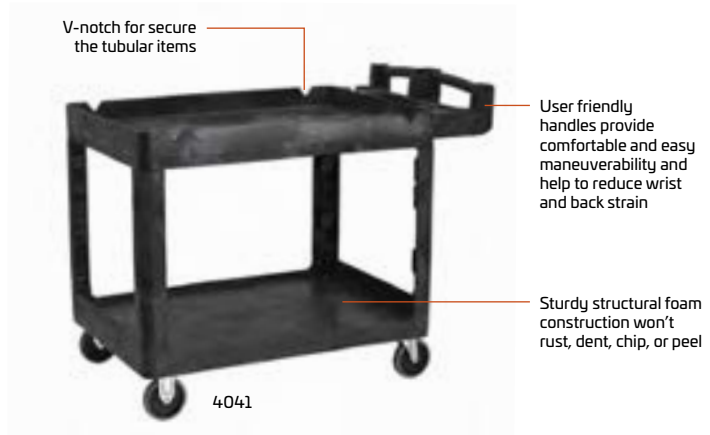

4042



4043



4044



4046

| Model | Description | Dimensions | Load | Color | Caster Type | Pack |
|-------|----------------------------------|-----------------------|-------|-----------|-------------|------|
| 4041 | BITBAR® 2-shelf Utility Cart | 115.0 × 64.1 × 98.7cm | 230kg | BLA, BEIG | 12.5cm TPR | 1 |
| 4042 | BITBAR® Utility Cart with Drawer | 115.0 × 64.1 × 98.7cm | 230kg | BLA, BEIG | 12.5cm TPR | 1 |
| 4043 | BITBAR® 3-shelf Utility Cart | 115.0 × 64.1 × 98.7cm | 230kg | BLA, BEIG | 12.5cm TPR | 1 |
| 4044 | BITBAR® 2-shelf Utility Cart | 97.8 × 43.5 × 98.7cm | 230kg | BLA, BEIG | 12.5cm TPR | 1 |
| 4046 | BITBAR® 3-shelf Utility Cart | 97.8 × 43.5 × 98.7cm | 230kg | BLA, BEIG | 12.5cm TPR | 1 |

BITBAR® FLAT-SHELF CARTS



PRODUCT FEATURES:

1. Innovative design for easy transportation of any item.
2. Sturdy structural foam construction won't rust, dent, chip, or peel.
3. Molded-in storage compartments and cup holder are suitable for storage of small items and tools.
4. User friendly handles provide comfortable and easy maneuverability.
5. Integrated molded grooves for inserting steel tube or metal reeled coils or other scroll-like items.



4047

| Model | Description | Dimensions | Load | Color | Caster Type | Pack |
|-------|---|----------------------|-------|-----------|-------------|------|
| 4045 | BITBAR® 2-shelf Utility Cart Flat Shelf | 97.8 × 43.5 × 96.8cm | 230kg | BLA, BEIG | 12.5cm TPR | 1 |
| 4047 | BITBAR® 3-shelf Utility Cart Flat Shelf | 97.8 × 43.5 × 96.8cm | 230kg | BLA, BEIG | 12.5cm TPR | 1 |

LADDER CARTS

PRODUCT FEATURES:

1. For storing and moving 1.8 m ladder without damaging walls, doors or elevators.
2. The cart body is made of commercial grade plastic and galvanized steel. Maximum load up to 250kg.
3. Compact design enhances the operability of the cart, and takes up less space.
4. Cart is ergonomically designed to offer a comfortable working height.
5. The cart is for storage of ladders and other long objects, and fits for a variety of work environments.

Lock rail to easily secure the ladder in place

Tool Holder provides a convenient location for small tools

4051

Sturdy structural foam

Two non-marking 12.5cm casters and two swivel casters with full-locking mechanism



Tool case can be used as a worktable once turned over



Tool Holder allows easy access to small tools



Unlock the rail to remove the ladder easily

| Model | Description | Dimensions | Load | Color | Pack |
|-------|-------------|-----------------------|-------|-------|------|
| 4051 | Ladder Cart | 80.5 × 69.1 × 112.1cm | 250kg | BLA | 1 |



MATERIAL SUPPLY CARTS



PRODUCT FEATURES:

1. Ideal choice for storing, counting and collecting goods.
2. Molded fabrication, strength and durability won't rust, dent, chip or peel.
3. Powder-coated steel handle is durable.
4. Various shelf positions available providing additional space for managing and transporting small cartons.
5. Carton recycling unit assures safe and clean aisles.



Various shelf (4063) positions available providing additional space for managing and transporting small cartons

Pre-installed armrest with a small table for easy recording

4821 Storage container, helps store small articles and improve work efficiency

4063/4821/4061



4062



Real-time carton recycling



Molded fabrication, strength and durability won't rust, dent, chip or peel

| Model | Description | Dimensions | Load | Color | Pack |
|-------|------------------------|------------------------|-------|-------|------|
| 4061 | Material Supply Cart | 163.4 × 45.4 × 163.2cm | 810kg | BLA | 1 |
| 4062 | Material Supply Cart | 196.0 × 45.4 × 163.2cm | 810kg | BLA | 1 |
| 4063 | Shelf for 4061 | 163.4 × 45.4 × 7.0cm | N/A | BLA | 1 |
| 4064 | Shelf for 4062 | 196.0 × 45.4 × 7.0cm | N/A | BLA | 1 |
| 4065 | Carton Recovery System | 66.5 × 38.2 × 76.5cm | N/A | YEL | 1 |



CASTERS SELECTION GUIDE

TRUST carts and trucks use top quality casters to meet every demand.

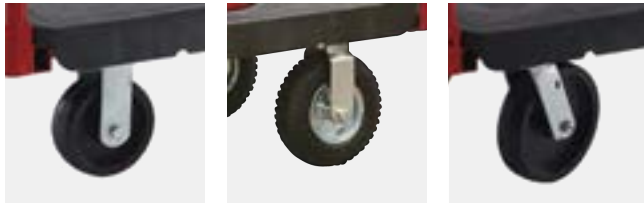

PP Casters

PP casters are easier to move than soft casters. They are non-marking, resistant to impact and chemical corrosion, and will neither slide off course, nor suffer damage from metal debris or nails under load. Excellent on concrete, wood, carpet and steel surfaces.

Pneumatic Casters

Ideal for fragile goods. Allows the trucks to run quietly on uneven rough surfaces as if they are moving across a soft cushion. Excellent on nearly all surfaces, including smooth concrete and rough gravel surfaces.

TPR Casters

TPR casters help reduce shock, protect the floor and run quietly. Excellent on tiles, Terrazzo, wood, smooth concrete, and carpets.



CASTERS PERFORMANCE GUIDE

| | Environmental Conditions | TPR Casters | PP Casters | Pneumatic Casters |
|-------------------|-------------------------------------|--------------------|------------|-------------------|
| Ground | Asphalt | ●●● | ● | ●●● |
| | Bricks | ●●● | ● | ●●● |
| | Carpet | ●●● | ●● | ●●● |
| | Concrete | ●●● | ●● | ●●● |
| | Asphalt Felt Ground tile | ●●● | ● | ●●● |
| | Steel Surface - textured | ●● | ● | ●●● |
| | Steel Surface - polished | ●● | ●● | ●●● |
| | Terrazzo | ●●● | ● | ●●● |
| | Wooden Floor | ●●● | ●● | ●●● |
| | Transportation Conditions | Moderate Chemicals | ● | ●● |
| Serious Chemicals | | ● | ● | ●● |
| Metal Debris - S | | ● | ●●● | ● |
| Metal Debris - L | | ● | ●● | ●● |
| Animal Fat | | ●● | ●● | ●● |
| Grease | | ● | ●● | ● |
| Water and Vapor | | ●● | ●●● | ●● |
| Other Factors | Ground Protection | ●●● | ●● | ●●● |
| | Quiet Transportation | ●●● | ● | ●●● |
| | Load Buffer | ●● | N/A | ●●● |
| | Resistance to Pressure | ●● | ●●● | ●●● |
| | Rolling Sensibility | ● | ●●● | ● |
| | Resistance to Wear (Not Damaged) | ● | ●● | ●●● |
| | No Extreme Wear (Under Static Load) | ● | ●●● | ●● |

Advanced Structural Foam Technology

- New technology, low pressure injection molding has no internal stress.
- Optimized composite structure of surface and core layers provides improved bend resistance per cross-section and increased stiffness of structural components.
- Honeycomb core layer has good cushioning performance and better impact resistance.
- Blend structure of plastic and metal has the carrying capacity 50-60% higher than that of traditional products.



World-class Durability

- When it comes to durability TRUST carts outperform industry peers.
- TRUST platform trucks have a unique design to ensure a long life and to make the job of operators easier.

Multiple Solutions

- We offer multiple products in different sizes to meet a wide variety of demands.



PLATFORM TRUCKS



OEASY® PLATFORM TRUCKS

PRODUCT FEATURES:

1. Perfect for transporting heavy loads in any environment.
2. User friendly handles help to maneuver the cart and ensure the safety of operators.
3. Molded-in structure adds strength and durability, and prolongs the service life.
4. Textured surfaces for non-skid and safe transporting.
5. Grooves close to edges help prevent small items from rolling out.
6. Notches on both sides are for secure latch of items.
7. Flexible fixing clip helps to prevent accidental release of handle while allowing easy disassembly.
8. Durable Powder-coated steel handle.



4411

Notches on both sides help latch items securely



Durable Powder-coated steel handle



User friendly handles help to maneuver the cart and ensure the safety of operators



Grooves close to edges help prevent small items from rolling out



Textured surfaces for non-skid and safe transporting



Flexible fixing clip helps to prevent accidental release of handle while allowing easy disassembly

| Model | Description | Deck Size | Dimensions | Load | Caster Type | Pack |
|-------|------------------------|----------------|------------------------|--------|------------------------|------|
| 4411 | OEASY® Platform Trucks | 91.4 × 61.0cm | 101.9 × 61.0 × 100.6cm | 450kg | 15.0 × 5.0cm TPR | 1 |
| 4412 | OEASY® Platform Trucks | 91.4 × 61.0cm | 101.9 × 61.0 × 100.6cm | 900kg | 15.0 × 5.0cm PP | 1 |
| 4413 | OEASY® Platform Trucks | 121.9 × 61.0cm | 132.4 × 61.0 × 105.7cm | 900kg | 20.0 × 5.0cm TPR | 1 |
| 4414 | OEASY® Platform Trucks | 121.9 × 61.0cm | 132.4 × 61.0 × 107.0cm | 540kg | 20.0 × 5.0cm Pneumatic | 1 |
| 4415 | OEASY® Platform Trucks | 121.9 × 61.0cm | 132.4 × 61.0 × 105.7cm | 1130kg | 20.0 × 5.0cm PP | 1 |
| 4416 | OEASY® Platform Trucks | 152.4 × 76.2cm | 162.9 × 76.2 × 105.7cm | 900kg | 20.0 × 5.0cm TPR | 1 |
| 4417 | OEASY® Platform Trucks | 152.4 × 76.2cm | 162.9 × 76.2 × 107.0cm | 540kg | 20.0 × 5.0cm Pneumatic | 1 |
| 4418 | OEASY® Platform Trucks | 152.4 × 76.2cm | 162.9 × 76.2 × 105.7cm | 1130kg | 20.0 × 5.0cm PP | 1 |

OEASY® A-FRAME PANEL TRUCKS



PRODUCT FEATURES:

1. Designed for transporting bulky plate-like items and difficult-to-move items, such as doors, wood, stone slab, tabletop and wardrobes, etc.
2. Molded-in structure adds strength and durability, and prolongs the service life.
3. Textured surfaces for non-skid and safe transporting.
4. Grooves close to edges help prevent small items from rolling out.
5. Notches on both sides help latch items securely.
6. Flexible fixing clip helps to prevent accidental release of handle while allowing easy disassembly.
7. Durable Powder-coated steel handle.



| Model | Description | Deck Size | Dimensions | Load | Caster Type | Pack |
|-------|-----------------------------|----------------|------------------------|-------|-----------------|------|
| 4421 | OEASY® A-Frame Panel Trucks | 91.4 × 61.0cm | 98.4 × 61.0 × 109.2cm | 900kg | 15.0 × 5.0cm PP | 1 |
| 4422 | OEASY® A-Frame Panel Trucks | 121.9 × 61.0cm | 128.9 × 61.0 × 114.0cm | 900kg | 20.0 × 5.0cm PP | 1 |
| 4423 | OEASY® A-Frame Panel Trucks | 152.4 × 76.2cm | 159.4 × 76.2 × 114.0cm | 900kg | 20.0 × 5.0cm PP | 1 |

OEASY® SHEET & PANEL TRUCKS



PRODUCT FEATURES:

1. Designed for transporting bulky plate-like items and difficult-to-move items, such as doors, wood, stone slab, tabletop and wardrobes, etc.
2. Molded-in structure adds strength and durability, and prolongs the service life.
3. Three removable power-coated steel vertical frames provide support for bulky loads. Frames can be removed as needed based on load requirements.
4. Textured surfaces for non-skid and safe transporting.
5. Grooves close to edges help prevent small items from rolling out.
6. Notches on both sides help latch items securely.
7. Flexible fixing clip helps to prevent accidental release of handle while allowing easy disassembly.
8. Durable Powder-coated steel handle.



| Model | Description | Deck Size | Dimensions | Load | Caster Type | Pack |
|-------|-----------------------------|----------------|------------------------|-------|-----------------|------|
| 4431 | OEASY® Sheet & Panel Trucks | 91.4 × 61.0cm | 98.4 × 61.0 × 109.2cm | 900kg | 15.0 × 5.0cm PP | 1 |
| 4432 | OEASY® Sheet & Panel Trucks | 121.9 × 61.0cm | 128.9 × 61.0 × 114.0cm | 900kg | 20.0 × 5.0cm PP | 1 |
| 4433 | OEASY® Sheet & Panel Trucks | 152.4 × 76.2cm | 159.4 × 76.2 × 114.0cm | 900kg | 20.0 × 5.0cm PP | 1 |

OEASY® WORK HEIGHT PLATFORM TRUCKS



PRODUCT FEATURES:

1. User-friendly cart is unique with height adjustable capacity to suit the operator.
2. Three height options ranging from 73cm to 88cm with an interval of 7.5cm are available for the work surface height.
3. User friendly handles help to maneuver the cart and ensure the safety of operators.
4. Molded-in structure adds strength and durability, and prolongs the service life.
5. Textured surfaces for non-skid and safe transporting.
6. Grooves close to edges help prevent small items from rolling out.
7. Notches on both sides are for secure latch of items.
8. Flexible fixing clip helps to prevent accidental release of handle while allowing easy disassembly.
9. Powder-coated steel handle is durable.
10. Two directional casters plus two universal casters ensure easy maneuverability.

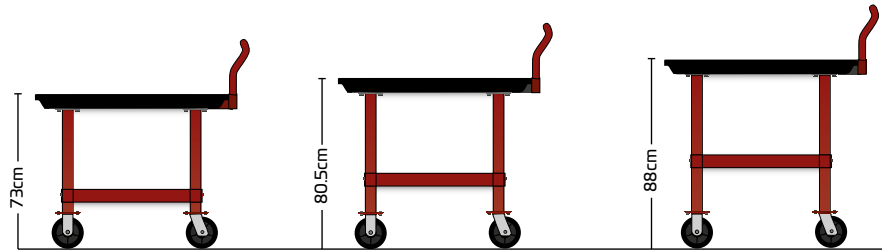

Three height options ranging from 73cm to 88cm with an interval of 7.5cm are available for different work surface heights.



Unique User-friendly cart with adjustable height to suit the user



Textured surfaces for non-skid and safe transporting



Flexible fixing clip helps to prevent accidental release of handle while allowing easy disassembly

| Model | Description | Deck Size | Dimensions | Load | Caster Type | Pack |
|-------|------------------------------------|----------------|------------------------|-------|------------------|------|
| 4441 | OEASY® Work Height Platform Trucks | 91.4 × 61.0cm | 98.4 × 61.0 × 114.0cm | 900kg | 15.0 × 5.0cm TPR | 1 |
| 4442 | OEASY® Work Height Platform Trucks | 121.9 × 61.0cm | 128.9 × 61.0 × 119.1cm | 900kg | 20.0 × 5.0cm TPR | 1 |
| 4443 | OEASY® Work Height Platform Trucks | 152.4 × 76.2cm | 159.4 × 76.2 × 119.1cm | 900kg | 20.0 × 5.0cm TPR | 1 |



OEASY® STANCHION PLATFORM TRUCKS



PRODUCT FEATURES:

1. Designed for transporting long and heavy pipes, wood and rolled stock, etc..
2. Molded-in structure adds strength and durability, and prolongs the service life.
3. Textured surfaces for non-skid and safe transporting.
4. Grooves close to edges help prevent small items from rolling out.
5. Notches on both sides help latch items securely.
6. Flexible fixing clip helps to prevent accidental release of handle while allowing easy disassembly.
7. Two directional casters plus two universal casters ensure easy maneuverability.

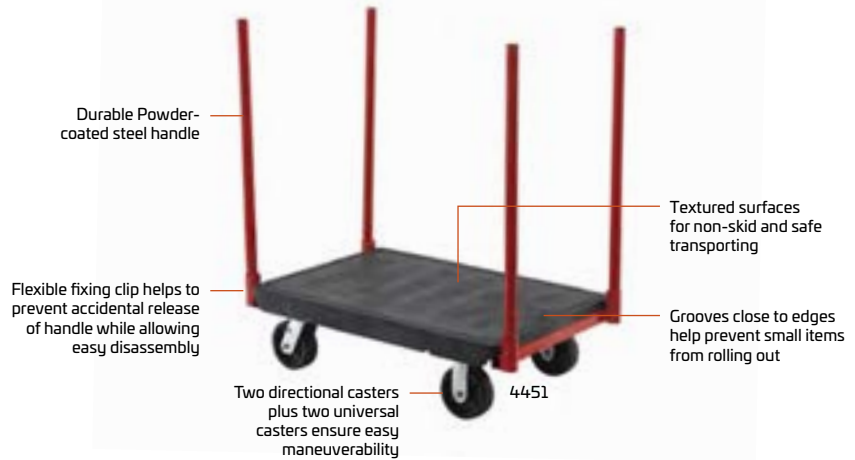

| Model | Description | Deck Size | Dimensions | Load | Caster Type | Pack |
|-------|---------------------------------|----------------|------------------------|--------|-----------------|------|
| 4451 | OEASY® Stanchion Platform Truck | 91.4 × 61.0cm | 98.4 × 61.0 × 103.2cm | 1130kg | 15.0 × 5.0cm PP | 1 |
| 4452 | OEASY® Stanchion Platform Truck | 121.9 × 61.0cm | 128.9 × 61.0 × 108.0cm | 1130kg | 20.0 × 5.0cm PP | 1 |
| 4453 | OEASY® Stanchion Platform Truck | 152.4 × 76.2cm | 159.4 × 76.2 × 108.0cm | 1130kg | 20.0 × 5.0cm PP | 1 |

OEASY® SKID PLATFORM TRUCKS



PRODUCT FEATURES:

1. An ideal choice for moving, temporary storing and supplementing materials.
2. Molded construction adds to strength, durability and extended service life.
3. Textured non-slip surface for added safety.
4. There are two notches on both sides of platform for latching of objects to enhance security.
5. Mobile jack handle is Powder-coated and durable; designed with a large steering angle to fit tight spaces.
6. Jack handle is sold separately.



| Model | Description | Deck Size | Dimensions | Load | Caster Type | Pack |
|-------|----------------------------------|----------------|-----------------------|-------|------------------|------|
| 4471 | OEASY® Skid Platform Truck | 91.4 × 61.0cm | 96.5 × 61.0 × 31.8cm | 900kg | 20.0 × 5.0cm TPR | 1 |
| 4472 | OEASY® Skid Platform Truck | 122.0 × 61.0cm | 127.0 × 61.0 × 31.8cm | 900kg | 20.0 × 5.0cm TPR | 1 |
| 4473 | OEASY® Skid Platform Truck | 152.0 × 76.0cm | 157.0 × 76.0 × 31.8cm | 900kg | 20.0 × 5.0cm TPR | 1 |
| 4474 | OEASY® Skid Platform Jack Handle | N/A | 127.0 × 29.8 × 26.0cm | 900kg | 20.0 × 5.0cm TPR | 1 |



PLATFORM TRUCKS

OEASY® PANEL PLATFORM TRUCKS



PRODUCT FEATURES:

1. Designed to deliver small parcels and objects.
2. Powder-coated wire cage around the truck ensures effective protection of goods carried.
3. Cage is removable to allow for transporting jumbo sized objects.
4. User-friendly handrails for easy maneuverability and improved worker safety.
5. Sturdy and durable structural foam construction adds to the durability and service life of the cart.
6. Designed with elastic retaining clip to effectively prevent the handrail from coming off; and offers easy disassembly/assembly.
7. Durable Powder-coated steel handle.
8. Two directional casters plus two universal casters ensure easy maneuverability.



Wire cage sides are easy to dismantle for accommodating objects of various sizes

| Model | Description | Deck Size | Dimensions | Load | Caster Type | Pack |
|-------|------------------------------|----------------|------------------------|-------|------------------------|------|
| 4461 | OEASY® Panel Platform Trucks | 91.4 × 61.0cm | 111.8 × 61.0 × 99.7cm | 450kg | 15.0 × 5.0cm TPR | 1 |
| 4462 | OEASY® Panel Platform Trucks | 121.9 × 61.0cm | 142.2 × 61.0 × 105.4cm | 550kg | 20.0 × 5.0cm Pneumatic | 1 |
| 4463 | OEASY® Panel Platform Trucks | 121.9 × 61.0cm | 142.2 × 61.0 × 104.8cm | 900kg | 20.0 × 5.0cm TPR | 1 |
| 4464 | OEASY® Panel Platform Trucks | 152.4 × 76.2cm | 173.0 × 76.2 × 105.4cm | 550kg | 20.0 × 5.0cm Pneumatic | 1 |
| 4465 | OEASY® Panel Platform Trucks | 152.4 × 76.2cm | 173.0 × 76.2 × 104.8cm | 900kg | 20.0 × 5.0cm TPR | 1 |

UTILITY TROLLEYS



PRODUCT FEATURES:

1. Efficiently transports large bulky loads, and then folds flat for easy storage.
2. Sturdy structural foam deck won't rust, dent, chip, or peel.
3. Non-skid platform surface helps prevent loads from shifting.
4. Three-position handle lets users push, pull or fold flat for use as a dolly.
5. Non marking casters.



Three handle positions provide greater flexibility, and convenient storage

| Model | Description | Dimensions | Load | Color | Pack |
|-------|--|---------------|-------|-------|------|
| 4481 | Utility Trolley, Utility Duty with 7.5cm Casters | 85.0 × 52.1cm | 110kg | BLA | 1 |
| 4482 | Utility Trolley, Standard Duty with 12.5cm Casters | 85.0 × 52.1cm | 230kg | BLA | 1 |

TOTES TROLLEYS



PRODUCT FEATURES:

1. Maneuverability for carrying heavy objects.
2. Sturdy structural foam construction won't rust, dent, chip, or peel.
3. Non-marking swivel casters ensure easy maneuverability.
4. Use 4483 to load Large Totes (3011/3012) and 55.5 × 35.0cm Containers.
5. Use 8888 used to load 60.0 × 40.0cm Containers.
6. Use 8889 to load 69.0 × 49.0cm Containers.



4483



8888



8889



Maneuverability for carrying heavy objects



Stackable for easy storage and space saving

| Model | Description | Dimensions | Load | Color | Pack |
|-------|---------------|----------------------|-------|-------|------|
| 4483 | Totes Trolley | 63.0 × 43.5 × 18.5cm | 150kg | BLA | 1 |
| 8888 | Totes Trolley | 67.6 × 43.6 × 17.3cm | 150kg | BLA | 1 |
| 8889 | Totes Trolley | 75.5 × 51.7 × 16.5cm | 150kg | BLA | 1 |



CUBE TRUCKS



CUBE TRUCKS

PRODUCT FEATURES:

1. For waste collection, material transport and laundry handling.
2. Rotomolded, industrial-grade strength, transports heavy loads with ease.
3. Metal frame provides durable support.



Domed, hinged lid conceals loads without reducing capacity



4711



4712

| Model | Description | Dimensions | Load | Color | Pack |
|-------|--|-----------------------|-------|-------------------------|------|
| 4710 | 0.2m ³ Cube Truck | 98.0 × 72.0 × 76.0cm | 135kg | BLA | 2 |
| 4711 | 0.3m ³ Cube Truck | 114.5 × 75.0 × 88.0cm | 180kg | GRN, RED, YEL, WHT, BLA | 2 |
| 4712 | 0.3m ³ Heavy-duty Utility Truck | 114.5 × 75.0 × 89.3cm | 360kg | BLA | 2 |
| 4713 | Lid for 4711/4712 | 113.0 × 70.5 × 13.2cm | N/A | BLA | 1 |
| 4714 | 0.4m ³ Cube Truck | 117.0 × 84.0 × 86.0cm | 230kg | BLA | 2 |
| 4715 | 0.5m ³ Cube Truck | 125.5 × 92.0 × 94.0cm | 230kg | BLA | 2 |



TILT TRUCKS



ROTOMOLDED TILT TRUCKS

PRODUCT FEATURES:

1. Fits through standard commercial doorways and onto elevators easily.
2. Angled design of the front end assists in emptying.
3. Industrial strength trucks handle heavy loads with ease.
4. Insert wheel position helps prevent damage to walls, equipment and customers.
5. Smooth surfaces are easy to clean and resist corrosion.
6. Optional hinged domed lid available.



4512

4522

| Model | Description | Dimensions | Load | Color | Pack |
|-------|--------------------------|------------------------|-------|-------|------|
| 4512 | Tilt Truck | 183.2 × 85.1 × 111.4cm | 270kg | BLA | 1 |
| 4522 | Tilt Truck, Utility Duty | 183.2 × 85.1 × 111.4cm | 390kg | BLA | 1 |

HEAVY-DUTY TOWABLE TILT TRUCKS

PRODUCT FEATURES:

1. Heavy-duty tow bar, hitch and frame for multiple truck towing and training.
2. Pneumatic wheels for smooth movement over various terrain surfaces or stairs.



4532

| Model | Description | Dimensions | Load | Color | Pack |
|-------|-------------------------------|------------------------|-------|-------|------|
| 4532 | Heavy-duty Towable Tilt Truck | 183.2 × 85.1 × 111.4cm | 950kg | BLA | 1 |

HEAVY-DUTY FORKLIFTABLE TILT TRUCKS

PRODUCT FEATURES:

1. Fully compatible with forklifts.
2. Multi-purpose, durable, welded fork pockets.



4542

| Model | Description | Dimensions | Load | Color | Pack |
|-------|------------------------------------|------------------------|-------|-------|------|
| 4542 | Heavy-duty Forkliftable Tilt Truck | 183.2 × 85.1 × 111.4cm | 570kg | BLA | 1 |

STRUCTURAL FOAM TILT TRUCKS

PRODUCT FEATURES:

1. Molded construction adds to strength, transports heavy loads with ease.
2. Easy access to standard doors and lifts.
3. Non-marking wheels prevent floor marking and reduce the post-job clean-up.
4. Easily operated by a single person.
5. Easy to clean, maintenance-free.
6. Optional hinged domed lid available.



4612



4614

| Model | Description | Dimensions | Capacity | Load | Color | Pack |
|-------|---------------------------|-----------------------|-------------------|-------|-------|------|
| 4611 | Tilt Truck, Utility Duty | 145.7 × 68.3 × 86.1cm | 0.4m ³ | 200kg | BLA | 1 |
| 4612 | Tilt Truck, Standard Duty | 145.7 × 68.3 × 86.1cm | 0.4m ³ | 380kg | BLA | 1 |
| 4613 | Tilt Truck, Utility Duty | 163.8 × 76.8 × 96.5cm | 0.6m ³ | 270kg | BLA | 1 |
| 4614 | Tilt Truck, Standard Duty | 163.8 × 76.8 × 96.5cm | 0.6m ³ | 450kg | BLA | 1 |



TILT TRUCK COVERS

PRODUCT FEATURES:

1. Rotomolded, industrial-grade strength, sturdy and durable.
2. Foldable, easy to stock.



| Model | Description | Dimensions | Capacity | Color | Pack |
|-------|-------------------------------|-----------------------|----------|-------|------|
| 4513 | Cover for 4512/4522/4532/4542 | 183.2 × 85.1 × 21.5cm | N/A | BLA | 1 |
| 4615 | Cover for 4611/4612 | 132.1 × 70.8 × 22.9cm | N/A | BLA | 1 |
| 4616 | Cover for 4613/4614 | 154.9 × 80.6 × 22.9cm | N/A | BLA | 1 |

COLLAPSIBLE LINEN CARTS

PRODUCT FEATURES:

1. Suitable for collecting and transporting non-sharp items and laundries, etc.
2. Compact, collapsible frame reduces space by 73% to enable efficient storage and transport.
3. Durable, lightweight and easy to control.
4. Non-marking swivel castors allow easy movement in narrow spaces, providing quiet operation and minimizing floor repair work.
5. Bumpers available at four corners to protect walls and equipment.
6. Durable Powder-coated steel frame.
7. Sturdy and durable vinyl bag, easy to clean.
8. Specially designed trailer function can connect multiple carts to improve transportation efficiency
9. Cover is sold separately.

COVER

PRODUCT FEATURES:

1. High quality vinyl cover, easy to clean.
2. Built-in storage bag allows convenient storage of various cleaning tools.
3. Zipper on the top provides easy access to the items inside without removing the cover.



| Model | Description | Dimensions | Capacity | Color | Pack |
|-------|---------------------------|----------------------|----------|-------|------|
| 5088 | Collapsible Linen Cart | 65.2 × 53.8 × 82.0cm | 120L | GRAY | 1 |
| 5089 | Collapsible Linen Cart | 76.7 × 64.2 × 82.0cm | 200L | GRAY | 1 |
| 5090 | Collapsible Linen Cart | 94.2 × 64.2 × 82.0cm | 240L | GRAY | 1 |
| 5091 | Cloth/Straw Bag, for 5088 | 52.0 × 40.0 × 60.0cm | 120L | BLA | 2 |
| 5092 | Cloth/Straw Bag, for 5089 | 67.0 × 51.0 × 60.0cm | 200L | BLA | 2 |
| 5093 | Cloth/Straw Bag, for 5090 | 80.2 × 51.0 × 60.0cm | 240L | BLA | 2 |
| 5094 | Cover for 5088 | 56.0 × 45.0 × 23.0cm | N/A | BLA | 2 |
| 5097 | Cover for 5089 | 68.0 × 55.0 × 23.0cm | N/A | BLA | 2 |
| 5098 | Cover for 5090 | 85.0 × 55.0 × 23.0cm | N/A | BLA | 2 |

| | | | |
|------------|-----------|----|--------|
| 147383 | CH4 UTE 4 | A | 0 |
| 78 | | | 0 |
| Team Alert | 15 | 11 | 00:58 |
| Defekt | 0% | 0 | 0 |
| 13.10.2021 | | | Monday |



UTILITY SERVICE CARTS



HIS® UTILITY SERVICE CARTS

PRODUCT FEATURES:

1. Versatile, durable for indoor mobility.
2. Molded shelves won't rust, dent, peel.
3. Aluminum uprights engineered for durability and appearance.
4. Convenient handles located on each end and compact size enhance maneuverability.
5. Quiet, non-marking swivel casters.
6. Non-slip surface texture.



All-plastic molded shelves engineered for durability, Textured surface for non-slip performance



Convenient handles located on each end and compact size enhance maneuverability



Specially configured end caps for easy fitting of bins



Quiet, non-marking swivel casters

| Model | Description | Dimensions | Load | Color | Pack |
|-------|---|----------------------|------|-----------------------|------|
| 4010 | HIS® Utility Cart, 2-shelf Unit | 85.4 × 47.3 × 96.0cm | 60kg | GRAY, BLA, PLAT, OWHT | 1 |
| 4011 | HIS® Utility Cart, Open Sided | 85.4 × 47.3 × 96.0cm | 90kg | GRAY, BLA, PLAT, OWHT | 1 |
| 4012 | HIS® Utility Cart with Enclose End Panels on 2 Sides | 85.4 × 47.3 × 96.0cm | 90kg | BLA, PLAT | 1 |
| 4013 | HIS® Utility Cart with Lockable Doors, Sliding Drawer | 85.4 × 47.3 × 96.0cm | 90kg | BLA | 1 |

HIS[®] UTILITY SERVICE CARTS

PRODUCT FEATURES:

1. Versatile, durable for indoor mobility.
2. Molded shelves won't rust, dent, peel.
3. Aluminum uprights engineered for durability and appearance.
4. Convenient handles located on each end and compact size enhance maneuverability.
5. Quiet, non-marking swivel casters.
6. Non-slip surface texture.
7. Large shelves suitable for a variety of equipment and supplies.



4021



4022



4023



4024



4025



4026



All-plastic molded shelves engineered for durability, Textured surface for non-slip performance



Specially configured end caps for easy fitting of bins



Quiet, non-marking swivel casters

| Model | Description | Dimensions | Load | Color | Pack |
|-------|---|------------------------|-------|-----------------|------|
| 4020 | HIS [®] Utility Cart, 2-Shelf Unit | 103.2 × 50.8 × 96.0cm | 90kg | BLA | 1 |
| 4021 | HIS [®] Utility Cart, Open Sided | 103.2 × 50.8 × 96.0cm | 135kg | GRAY, BLA, OWHT | 1 |
| 4022 | HIS [®] Utility Cart with Enclosed End Panels on 2 Sides | 103.2 × 50.8 × 96.0cm | 135kg | BLA, OWHT | 1 |
| 4023 | HIS [®] Utility Cart with Enclosed End Panels on 3 Sides | 103.2 × 50.8 × 96.0cm | 135kg | BLA, OWHT | 1 |
| 4024 | HIS [®] Utility Cart with Lockable Doors, Sliding Drawer | 103.2 × 50.8 × 96.0cm | 135kg | GRAY | 1 |
| 4025 | HIS [®] Equipment Cart | 103.2 × 50.8 × 96.0cm | 135kg | BLA | 1 |
| 4026 | HIS [®] 4 Shelf Cart | 103.2 × 50.8 × 129.5cm | 135kg | BLA | 1 |
| 4027 | HIS [®] Utility Cart with two sets of Lockable Doors | 103.2 × 50.8 × 96.0cm | 135kg | BLA | 1 |

HI5® FOLDING SERVICE CARTS

PRODUCT FEATURES:

1. Versatile, durable for indoor mobility.
2. Molded shelves sturdy and durable won't rust, dent, peel.
3. Fully functional and innovative folding mechanism can be easily folded and opened, saving 50% of the space once folded.
4. Quick locking device to ensures cart remains in position after opening or folding.
5. Comfortable ergonomic handle for more flexible control.
6. Textured surfaces for non-slip and safe transportation.
7. Spacious countertop for the 4072 cart, which can accommodate two lower railing basins at the same time (8221).
8. 10cm silent no-marking castors which is designed to reduce noise and floor wear and tear; Universal wheel with brake function for stability when working.



Comfortable ergonomic handle for more flexible control



Quick locking device to ensures cart remains in position after opening or folding



Innovative folding mechanism makes it easier to open and fold



10cm quiet, non-marking castors

| Model | Description | Dimensions | Load | Color | Pack |
|-------|----------------------------|-----------------------|-------|----------------|------|
| 4071 | HI5® Foldable Service Cart | 75.0 × 41.2 × 92.0cm | 160kg | GRAY, BLA, BRN | 1 |
| 4072 | HI5® Foldable Service Cart | 102.5 × 52.3 × 92.0cm | 160kg | GRAY, BLA, BRN | 1 |



H15® UTILITY SERVICE CARTS



PRODUCT FEATURES:

1. Sturdy and durable, fully functional carts, suitable for handling work in the front and back of house.
2. The sturdy and durable structure of the entire cart is form molded, and will not rust, dent or come apart.
3. Ergonomic, comfortable handle provides flexible control.
4. Textured surfaces for non-slip and safe transportation.
5. With a spacious countertop, two lower railing basins can be placed side by side (8211).
6. 10cm silent no-marking castors which is designed to reduce noise and floor wear and tear.
7. The sundries barrels (4811, 4821) can be placed on both sides to increase collection capacity.



4081



4082



4083



4084

| Model | Description | Dimensions | Load | Color | Pack |
|-------|--|-----------------------|-------|-------|------|
| 4081 | H15® Utility Cart | 111.6 × 54.0 × 95.6cm | 135kg | BLA | 1 |
| 4082 | H15® Utility Cart with Enclosed End Panels on 3 Sides | 111.6 × 54.0 × 95.6cm | 135kg | BLA | 1 |
| 4083 | H15® Utility Cart with Lockable Doors, Sliding Drawer | 111.6 × 54.0 × 95.6cm | 135kg | BLA | 1 |
| 4084 | H15® Utility Cart with Lockable Doors, Enclosed Panels | 111.6 × 54.0 × 95.6cm | 135kg | BLA | 1 |

ACCESSORIES



4811



4821



4851

| Model | Description | Dimensions | Capacity | Color | Pack |
|-------|------------------------|----------------------|----------|----------|------|
| 4085 | Enclosed Panels | N/A | N/A | BLA | 1 |
| 4086 | Lockable Doors | N/A | N/A | BLA | 1 |
| 4087 | Trim Panel | 50.6 × 30.8 × 3.7cm | N/A | BLA | 1 |
| 4811 | Utility Bin | 43.2 × 30.8 × 26.7cm | 15L | BLA | 2 |
| 4821 | Utility Bin | 43.2 × 30.8 × 55.9cm | 30L | BLA | 2 |
| 4851 | Utility Sliding Drawer | 65.7 × 46.0 × 8.2cm | N/A | BLA, BRN | 1 |

UTILITY SERVICE CART ACCESSORIES COMPATIBILITY GUIDE

| Cart Model | 4811 15L Utility Bin Pack: 2 Color: BLA | 4821 30L Refuse Bin Pack: 2 Color: BLA | 4830 Hook Kit (Set of 4) Pack: 1 Color: BLA | 4831 20cm Pneumatic Caster Kit Pack: 1 | 4832 Ultra Silent Caster Kit (Set of 4) Pack: 1 Color: GRAY | 4841 Single Full Extension Drawer Pack: 1 Color: RED | 4850 Utility Sliding Drawer Pack: 1 Color: BLA | 4851 Utility Sliding Drawer Pack: 1 Color: BRN, BLA |
|------------|---|--|---|---|---|--|--|---|
| 4011 | ● | ● | ● | | ● | | ● | |
| 4012 | ● | ● | ● | | ● | | ● | |
| 4013 | ● | ● | ● | | ● | | ● | |
| 4021 | ● | ● | ● | | ● | | | ● |
| 4022 | ● | ● | ● | | ● | | | ● |
| 4023 | ● | ● | ● | | ● | | | ● |
| 4024 | ● | ● | ● | | ● | | | ● |
| 4025 | ● | ● | ● | | ● | | | ● |
| 4026 | ● | ● | ● | | ● | | | ● |
| 4031 | ● | ● | ● | ● | | | | |
| 4032 | ● | ● | ● | ● | | | | |
| 4033 | ● | ● | ● | ● | | | | |
| 4041 | ● | ● | ● | ● | | ● | | |
| 4042 | ● | ● | ● | ● | | ● | | |
| 4043 | ● | ● | ● | ● | | ● | | |
| 4044 | ● | ● | ● | ● | | | | |
| 4045 | | | | ● | | | | |
| 4046 | ● | ● | | ● | | | | |
| 4047 | | | | ● | | | | |
| 4061 | ● | ● | | ● | | | | |
| 4062 | ● | ● | | ● | | | | |
| 4081 | ● | ● | ● | | | | | ● |
| 4082 | ● | ● | ● | | | | | ● |
| 4083 | ● | ● | ● | | | | | ● |
| 4084 | ● | ● | ● | | | | | ● |







SHELVING SYSTEMS

PRODUCT FEATURES:

1. Store, organize and transport in style with these durable, and attractive shelving units.
2. Stationary shelves feature molded feet for added stability.
3. Mobile shelf trucks come with 4 casters (two with brake).
4. Locking doors are optional for 3711, 3712, 3715, 3716.
5. Units are available with four, five or six shelves and a variety of heights up to 184cm.
6. Shelves feature aluminum uprights for smart appearance and durability.
7. Steel bar reinforced molded shelves support higher loads.
8. Textured shelves have higher load capacity.
9. Large shelves can hold a variety of equipment and supplies.



Enclosed panels (3719) and lockable doors (3718) are available for 3711/3712/3715/3716



| Model | Description | Dimensions | Load | Color | Pack |
|-------|---|-----------------------|-------|-------|------|
| 3711 | Shelving, 4-shelf Unit | 89.2 × 50.8 × 116.0cm | 360kg | BLA | 1 |
| 3712 | Shelving, 5-shelf Unit | 89.2 × 50.8 × 150.0cm | 360kg | BLA | 1 |
| 3713 | Shelving, 4-shelf Unit | 89.2 × 50.8 × 180.0cm | 360kg | BLA | 1 |
| 3714 | Shelving, 5-shelf Unit | 89.2 × 50.8 × 180.0cm | 360kg | BLA | 1 |
| 3715 | Shelving, 6-shelf Unit | 89.2 × 50.8 × 184.0cm | 360kg | BLA | 1 |
| 3716 | Mobile Shelf Truck, 5-shelf Unit | 89.2 × 50.8 × 153.0cm | 360kg | BLA | 1 |
| 3717 | Mobile Shelf Truck, 4-shelf Unit | 89.2 × 50.8 × 184.0cm | 360kg | BLA | 1 |
| 3718 | Lockable Doors for 3711/3712/3715/3716 | N/A | N/A | BLA | 1 |
| 3719 | Enclosed Panels for 3711/3712/3715/3716 | N/A | N/A | BLA | 1 |

BITBAR® TOOL BOXES

PRODUCT FEATURES:

1. Removable trays provide added compartmentalized storage area.
2. Padlocked for security.
3. 3512 has a 3cm cushion on the top of box to provide a comfortable seat.
4. Handles are provided on both sides of 3511/3512, and optional casters (3513) are convenient for moving heavy objects.
5. 3514 has diverse compartments, for the orderly storage of a variety of tools with a transparent cover for quick identification of the items inside.



Built-in **two sub-grid boxes**, for easy storage



3512 with 3cm thick **comfortable cushion**



Parts box with transparent cover at both ends



3514 has **compartments**, which can be adjusted according to the tool size

| Model | Description | Dimensions | Load | Color | Pack |
|-------|------------------------|----------------------|-------|-------|------|
| 3511 | Tool Box | 91.6 × 47.0 × 50.9cm | 135kg | BLA | 1 |
| 3512 | Tool Box with Cushion | 91.6 × 47.0 × 53.9cm | 135kg | BLA | 1 |
| 3513 | Caster Kit (4 Units) | Dia 7.5 × 2.0cm | 135kg | BLA | 1 |
| 3514 | Multi-purpose Tool Box | 45.8 × 33.0 × 8.0cm | N/A | BLA | 1 |

THOR® LARGE TOTES WITH LID



PRODUCT FEATURES:

1. Reinforced ribbed bottom allows product to be dragged.
2. User friendly grip handles decrease the potential of hand injury.
3. Lid snaps tight, keeping contents secure.
4. Works with dollies for carrying heavy loads quickly and conveniently.



Works with **dollies** to carrying heavy loads fast and convenient



3011/3012

| Model | Description | Dimensions | Capacity | Color | Pack |
|-------|---------------|----------------------|----------|-----------|------|
| 3011 | Tote With Lid | 70.8 × 43.4 × 27.2cm | 53L | GRAY, WHT | 6 |
| 3012 | Tote With Lid | 70.8 × 43.4 × 38.4cm | 75L | GRAY, WHT | 6 |
| 4483 | Totes Trolley | 63.0 × 43.5 × 18.5cm | N/A | BLA | 1 |

THOR® STACKABLE TOTE BINS



PRODUCT FEATURES:

1. Fits 120 × 100cm pallets with no overhang.
2. Nestable for efficient storage and transport.
3. Stackable with and without lids.
4. All-plastic construction will not rust, dent, chip, or peel.
5. Complies with the requirements of NSF #2.



3021



3022/3023

| Model | Description | Dimensions | Capacity | Color | Pack |
|-------|--------------------|----------------------|----------|-------|------|
| 3021 | Stackable Tote Bin | 59.2 × 39.2 × 27.0cm | 40L | GRAY | 6 |
| 3022 | Stackable Tote Bin | 59.2 × 39.2 × 36.0cm | 55L | GRAY | 6 |
| 3023 | Lid for 3021/3022 | 60.0 × 40.0 × 3.3cm | N/A | GRAY | 6 |



MULTI-FUNCTION LADDERS

PRODUCT FEATURES:

1. Complies with the requirements of ANSI 14.2, AS/NZS 1892.1 and EN-131.
2. Patented auto-locking hinge design.
3. Triple modes of A-shaped ladder, straight ladder and extension ladder.
4. Made with premium quality lightweight aluminum, with outstanding strength and durability.
5. Non-slip step design for safety.
6. Reliable soft tips.
7. Can be folded to one quarter of extended length to save space and transportation costs.
8. Can be extended to four times of length.



6945 Schematic Work Status

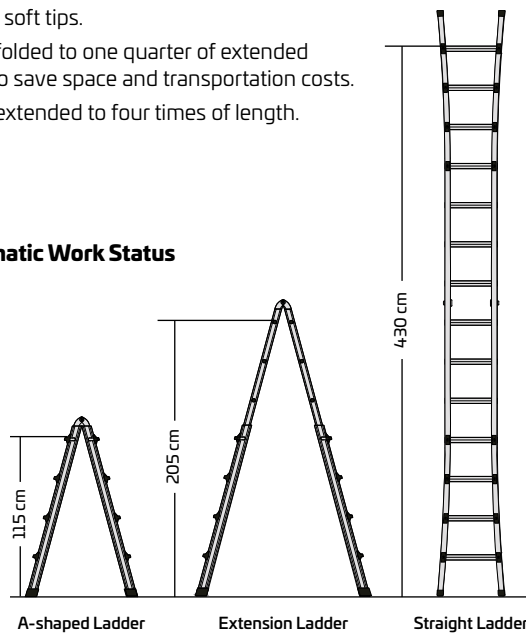

Can be quickly converted into a **straight ladder**, offers high operating convenience



Can be **used on the stairs**, safe and reliable

| Model | Description | Dimensions | Extension Length | Folding Length | Load | Color | Pack |
|-------|-----------------------|-----------------------|------------------|----------------|-------|-------|------|
| 6945 | Multi-function Ladder | 131.0 × 60.5 × 20.0cm | 452.0cm | 220.0cm | 150kg | MSILV | 1 |
| 6946 | Multi-function Ladder | 198.0 × 75.0 × 20.0cm | 686.0cm | 334.0cm | 150kg | MSILV | 1 |

FOLDING LADDERS

PRODUCT FEATURES:

1. Made from premium quality lightweight aluminum, with outstanding strength and durability.
2. Can be folded down easily and quickly, compactable for space saving.
3. Non-slip step design for enhanced safety.
4. Reliable foot pads.



| Model | Description | Dimensions | Load | Color | Pack |
|-------|---------------------------|--|-------|-------|------|
| 6943 | Two-step Folding Ladder | Open: 46.0 × 47.0 × 92.0cm Closed: 46.0 × 15.2 × 98.5cm | 120kg | BLA | 1 |
| 6944 | Three-step Folding Ladder | Open: 51.0 × 63.5 × 116.0cm Closed: 51.0 × 15.2 × 123.5cm | 120kg | BLA | 1 |

FOLDING STEPSTOOLS

PRODUCT FEATURES:

1. Slip resistant surfaces on steps and foot pads.
2. Easy to transport and space efficient with folded size only 15.9cm.
3. Plastic molded web-structure, supports loads up to 150kg.
4. Easy to clean and resistant to dents and rest.
5. Meets EN14183:2003 standards.



6932



Easy to transport

| Model | Description | Dimensions | Load | Color | Pack |
|-------|----------------------------|--|-------|------------------|------|
| 6932 | Two-step Folding Stepstool | Open: 47.5 x 51.5 x 59.0cm Closed: 47.5 x 15.9 x 65.0cm | 150kg | GRAY, DGRAY, BLA | 3 |

MOVABLE PEDALS

PRODUCT FEATURES:

1. Compression casters for easy mobility.
2. Load bearing up to 160kg.
3. Both pedals are equipped with a soft non-slip pad.
4. Casters retract automatically under load.
5. Heavy-duty plastic structure, solid and durable, and will not damage walls or furniture.
6. Meets EN14183:2003 standards.



6933



Compression casters for easy mobility

| Model | Description | Dimensions | Load | Color | Pack |
|-------|------------------------|---------------|-------|-----------|------|
| 6933 | Movable Two-step Pedal | 40.6 x 34.3cm | 160kg | BLA, BEIG | 1 |

ROTMOLDED PLASTIC PEDALS

PRODUCT FEATURES:

1. Rotomolded; industrial-grade; sturdy and durable.
2. One-piece body construction provides superior strength and durability.
3. All pedals are equipped with a soft non-slip pad.
4. Load bearing up to 160kg.
5. Rubber base pad with anti-skid function for increased security.
6. Four direction pedal design, easy to use.
7. Meets EN14183:2003 standards.



6930

| Model | Description | Dimensions | Load | Color | Pack |
|-------|--------------------------|----------------------|-------|----------|------|
| 6930 | Rotomolded Plastic Pedal | 49.0 x 49.0 x 36.4cm | 160kg | YEL, BLA | 1 |

STORAGE PALLETS

PRODUCT FEATURES:

1. For overflow operation as drum filling and sub-packaging, chemical and electrolyte storage etc.
2. Prevents leakages of most chemicals including acids, alkaline and corrosive liquids.
3. Molded construction adds to strength, strong and durable, will not rust, dent, chip, or peel.
4. Removable grid for gathering leaked fluids.
5. Optional 4503 slopes for handling heavy drums; rubber strips on surface assure safety.
6. Non-forklifting; no IBC containers allowed.



4501/4502/4503



4501



4502



4503

| Model | Description | Dimensions | Static Load | Capacity | Color | Pack |
|-------|-----------------------------|------------------------|-------------|----------|-------|------|
| 4501 | Storage Pallet, for 2 Drums | 124.5 × 63.5 × 14.0cm | 1130kg | 90L | BLA | 1 |
| 4502 | Storage Pallet, for 4 Drums | 124.5 × 124.5 × 14.0cm | 2260kg | 185L | BLA | 1 |
| 4503 | Slope, for 4501 and 4502 | 121.9 × 83.8 × 15.9cm | 450kg | N/A | BLA | 2 |

GOODS SHELVES



PRODUCT FEATURES:

1. Designed for storage of frozen, refrigerated or dry goods.
2. Structural foam molding ensures strength and durability.
3. Hollow pad offers maximized ventilation for perishable or dry goods.
4. Pad height meets NSF standards.
5. 4491 and 4493 Lock catches can lock goods shelves together for increased stability.

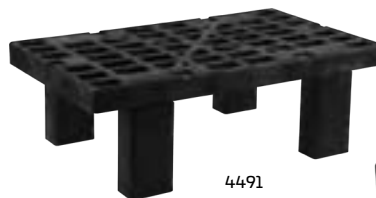

4491

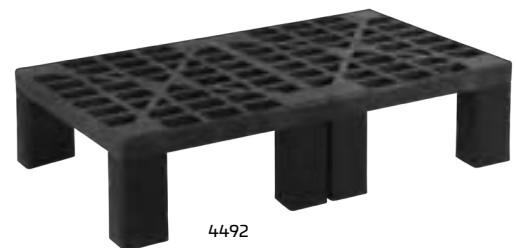

4492



Lock catches can lock goods shelves together for increased stability

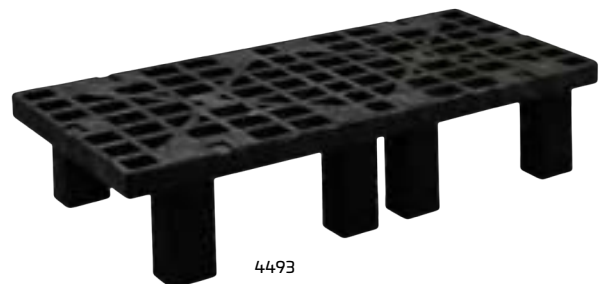

4493

| Model | Description | Dimensions | Load | Color | Pack |
|-------|-------------|-----------------------|--------|-------|------|
| 4491 | Goods Shelf | 91.0 × 53.3 × 30.5cm | 680kg | BLA | 1 |
| 4492 | Goods Shelf | 122.0 × 61.0 × 30.5cm | 900kg | BLA | 1 |
| 4493 | Goods Shelf | 152.0 × 53.3 × 30.5cm | 1360kg | BLA | 1 |



NESTABLE PALLETS

PRODUCT FEATURES:

1. Structural foam molded handles ensure strength and durability.
2. Nestable stacking, easy to clean, light weight.
3. Made from HDPE, which is recyclable and thus offers a low cost.
4. Materials comply with the requirements of domestic and foreign regulations on the international Food and Drug Sanitation regulations.



PNB1210



Stacking coefficient (2.2), to save storage space of the pallet



Designed for **easy entry of forklift** to save the time and make job simple



Vents are available on areas prone to water accumulation, so as to eliminate the possibility of water accumulation even when kept in open air

| Model | Description | Dimensions | Fork high | Load (Static/Dynamic) | Color |
|---------|-----------------|------------------------|-----------|-----------------------|-------|
| PNB1111 | Nestable Pallet | 110.0 × 110.0 × 14.7cm | 9.5cm | 2500kg / 1000kg | BLA |
| PNB1208 | Nestable Pallet | 120.0 × 80.0 × 14.7cm | 9.5cm | 2000kg / 1000kg | BLA |
| PNB1210 | Nestable Pallet | 120.0 × 100.0 × 14.8cm | 9.8cm | 2500kg / 1000kg | BLA |

SHELF PALLETS

PRODUCT FEATURES:

1. Structural foam molded handles ensure strength and durability.
2. Easy to clean, light weight.
3. Made from HDPE, which is recyclable and thus offers a low cost.
4. Integral double-sided plastic pallet structure suitable for stacking, shelving systems and cargo transportation.
5. Designed for cleanliness and improved sanitation helping to reduce cleaning frequency.
6. Pallet design is CAE optimized - lightweight with increased load capacity.



PRB1210

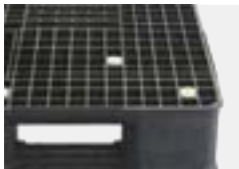

Designed for **easy forklift entry** to save time and reduce the possibility of damage



The **solid, extra-thick base ribs** are arranged to increase strength of pallet base, thus enhancing its shelving and stacking durability



The **grid structure** allows for easy and simple cleaning, and eliminates the problem of water accumulation even when stored in the open

| Model | Description | Dimensions | Fork high | Load (Static/Dynamic) | Color |
|---------|---------------|------------------------|-----------|-----------------------|-------|
| PRB1210 | Shelf Pallets | 120.0 × 100.0 × 16.7cm | 9.4cm | 13500kg / 2300kg | BLA |

STACKING PALLETS

PRODUCT FEATURES:

1. Structural foam molded handles ensure strength and durability.
2. Easy to clean, light weight.
3. Made from HDPE, which is recyclable and thus offers a low cost.
4. Pallet design is CAE optimized - lightweight with increased load capacity. Patented leg design for easy servicing.
5. All-plastic structure and smooth surfaces reduce the possibility of damage to products.
6. Materials comply with the requirements of domestic and international Food and Drug Sanitation regulations.



PSB1210



Patented detachable legs can be easily replaced if the pallet is partially damaged



The round corner of the leg and the beveled angle of the top and base plates are designed for **easy operation of forklifts**



Extra-large area base plate ensures maximized contact area between the material and the plate to enhance stacking stability

| Model | Description | Dimensions | Fork high | Load (Static/Dynamic) | Color |
|---------|-----------------|------------------------|-----------|-----------------------|-------|
| PSB1210 | Stacking Pallet | 120.0 × 100.0 × 14.9cm | 7.6cm | 4500kg / 1200kg | BLA |

HEAVY-LOAD BULK CONTAINERS

PRODUCT FEATURES:

1. Structural foam molded construction ensures strength and durability.
2. Easy to clean, lightweight.
3. Provides reliable protection for contents when used in picking, assembling, processing, warehousing and logistics operations in a variety of industries.

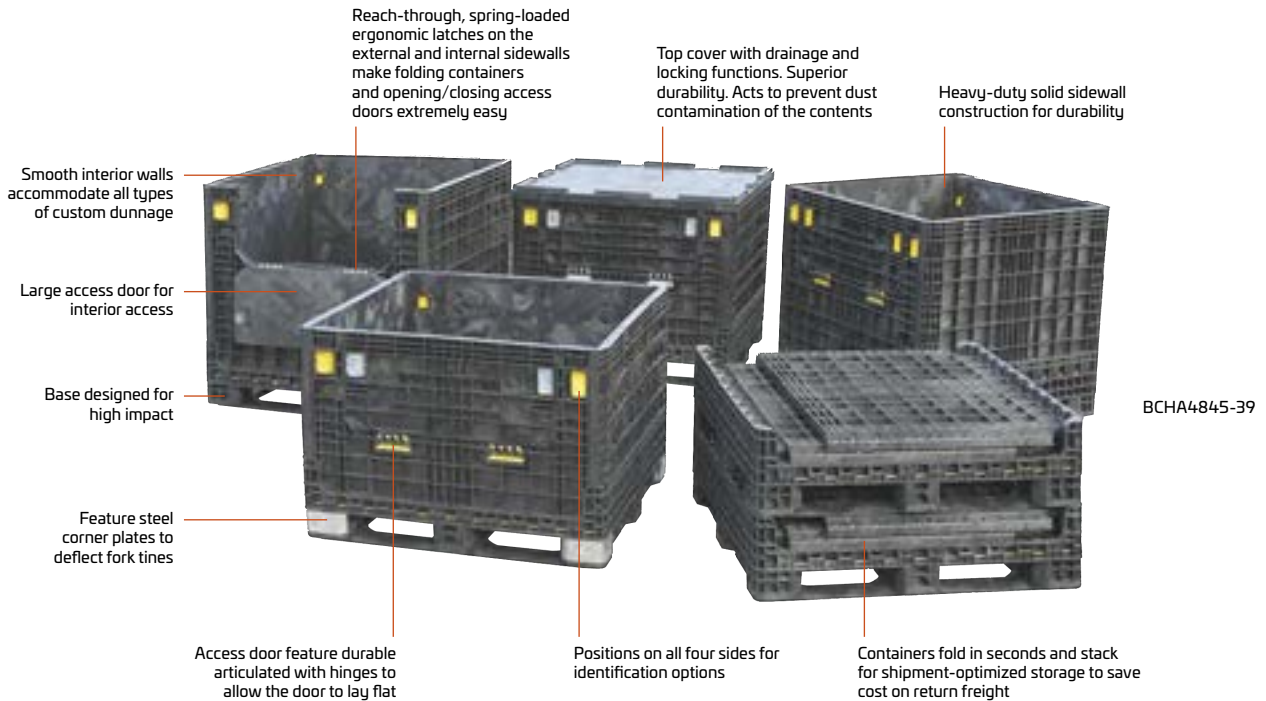

Large size flip door for easy loading and unloading of cargo



Top cover with drainage and locking functions. Superior durability. Acts to prevent dust contamination of the contents.



Secure stackability maximizes warehouse space without the use of racking



Bulk containers can be folded to save storage space and reduce transport cost

| Model | Description | Container External Dimension | Container Internal Dimension | Load | Color |
|-------------|---------------------------|------------------------------|------------------------------|-------|-------|
| BCHA1210-09 | Heavy-load Bulk Container | 120.0 × 100.0 × 87.1cm | 111.8 × 91.8 × 73.0cm | 788kg | BLA |
| BCHA1210-10 | Heavy-load Bulk Container | 120.0 × 100.0 × 97.5cm | 111.8 × 91.8 × 83.4cm | 788kg | BLA |
| BCHA1210-11 | Heavy-load Bulk Container | 120.0 × 100.0 × 107.4cm | 111.8 × 91.8 × 93.3cm | 675kg | BLA |
| BCHA4845-25 | Heavy-load Bulk Container | 121.9 × 114.3 × 63.5cm | 113.2 × 105.2 × 47.0cm | 900kg | BLA |
| BCHA4845-34 | Heavy-load Bulk Container | 121.9 × 114.3 × 86.3cm | 113.2 × 105.2 × 69.8cm | 788kg | BLA |
| BCHA4845-39 | Heavy-load Bulk Container | 121.9 × 114.3 × 99.0cm | 113.2 × 105.2 × 82.5cm | 788kg | BLA |
| BCHA4845-42 | Heavy-load Bulk Container | 121.9 × 114.3 × 106.6cm | 113.2 × 105.2 × 90.1cm | 675kg | BLA |
| BCHA4845-46 | Heavy-load Bulk Container | 121.9 × 114.3 × 116.8cm | 113.2 × 105.2 × 100.3cm | 675kg | BLA |
| BC1210 | Top | 122.0 × 101.9 × 8.8cm | N/A | N/A | BLA |
| BC4845 | Top | 124.3 × 116.7 × 7.7cm | N/A | N/A | BLA |



13

14



FOOD STORAGE

| | |
|---|-----|
| Food Material Storage Bins | 184 |
| Shelf-type Raw Food Material Containers | 185 |
| Goods Shelves | 185 |
| Thor® Food Storage Boxes | 186 |
| Thor® Stackable Food Storage Bins | 186 |
| Thor® Square Food Containers | 187 |
| Large Food Containers | 187 |
| Thor® Fresh Fruit and Vegetables Storage Bins with Lid and Cart | 188 |
| Thor® Ice Buckets | 188 |
| Food Pans | 190 |
| Cold Food Pans | 190 |
| Hot Food Pans | 190 |
| Lids with Handle | 193 |
| Lids with Opening and Handle | 193 |
| Flat Lids | 194 |
| Drain Trays | 194 |

| | |
|------------------------------------|-----|
| Cold Food Pans | 196 |
| Polycarbonate (PC) Cold Food Pans | 196 |
| Polypropylene (PP) Cold Food Pans | 196 |
| Lids with Handle | 198 |
| Lids with Entry and Handle | 198 |
| Flat Lid | 199 |
| Drain Trays | 199 |
| Round Storage Containers | 200 |
| Lids | 200 |
| Firmgre® storage system | 202 |
| Firmgre® Starter Kits & Extensions | 208 |
| Firmgre® Mobile Storage Kits | 210 |
| Firmgre® Parts & Accessory | 211 |
| Firmgre® Modus storage system | 214 |
| Firmgre® Modus Parts & Accessory | 216 |

INSULATED PRODUCTS

| | |
|-------------------|-----|
| Insulated Boxes | 218 |
| Insulated Bottles | 219 |

| | |
|----------------------------------|-----|
| Cold Drink Coolboxes | 219 |
| EXCEBOX® Insulated Food Carriers | 220 |
| Front-Loading EXCEBOX® | 224 |
| Top-Loading EXCEBOX® | 226 |
| EXCEBOX® Accessories | 228 |

TRANSPORT

| | |
|------------------------------|-----|
| Food Storage Racks/Carts | 230 |
| Adjustable Tray & Dish Carts | 231 |
| Oeasy® Platform Trucks | 232 |
| Hi5® Utility Service Carts | 232 |
| Hi5® Folding Service Carts | 233 |
| Hi5® Utility Service Carts | 234 |
| Accessories | 235 |
| Bitbar® Utility Carts | 236 |
| Bitbar® Flat-shelf Carts | 236 |
| Utility Trolleys | 238 |
| Glass Rack Trolleys | 238 |



| | |
|---------------------------|-----|
| Catering Disks | 239 |
| GRP Non-slip Trays | 239 |
| PP Non-slip Trays | 240 |
| Wood Grain Non-slip Trays | 240 |

FOOD PREPARATION

| | |
|-----------------|-----|
| Scraper | 242 |
| Chopping Boards | 243 |

DISHWASHING AND STORAGE

| | |
|-----------------------------------|-----|
| Cupcomb® Warewashing System | 244 |
| Cupcomb® Full Size Glass Racks | 245 |
| Cupcomb® Half Size Glass Racks | 247 |
| Cupcomb® Base / Flatware Racks | 248 |
| Cupcomb® Peg Rack | 249 |
| Cupcomb® Tray Rack | 249 |
| Cupcomb® Flatware Basket | 250 |
| Cupcomb® Extender and Accessories | 250 |

TOTE BOXES

| | |
|----------------------|-----|
| Tote Boxes | 254 |
| Cutlery Bins | 254 |
| Condiment Dispensers | 255 |
| Pitchers | 255 |
| Budget Pots | 255 |

YOUTH PRODUCTS

| | |
|---|-----|
| Kid&Cool® Microban® Youth Seats | 256 |
| Heimdall® Baby Changing Stations | 258 |
| Kid&Cool® Microban® Infant Safety Seats | 259 |

CLEANING TOOLS

| | |
|---------------------------------|-----|
| Floor Sweeps | 260 |
| Counter Brushes | 260 |
| Multi-purpose Brushes | 261 |
| Cleaning Brushes | 261 |
| Chopping Board Cleaning Brushes | 261 |
| Angle Brooms | 262 |

| | |
|-----------------------------------|-----|
| Vegetable Cleaning Brushes | 262 |
| Bottle Cleaning Brushes | 262 |
| Pipe Cleaning Brushes | 263 |
| High-temperature Cleaning Brushes | 263 |
| Coffee Machine Cleaning Brushes | 263 |
| Glass Brushes | 264 |
| Professional Plastic Squeegees | 264 |
| U-Rag® Superfine Fiber Cloths | 265 |
| Cleaning Tool Holders | 265 |



Improved Food Services

Our innovative products enhance food freshness, reduce costs, and improve service delivery.

Sustainability Commitment

Exceptional product design, sound recyclability and durability, and the use of environmentally friendly materials are our commitment to environmental sustainability.

Safety Commitment

Our products meet food preparation, storage and transport industry standards.





HACCP



HAZARD



ANALYSIS



CRITICAL



CONTROL



POINTS

What is HACCP

HACCP, which stands for Hazard Analysis Critical Control Points, is an internationally recognized method of identifying and managing food safety related risk. It is a management system in which food safety is addressed through the analysis and control of biological, chemical, and physical hazards from raw material production, procurement, and handling, to manufacturing, distribution and consumption of the finished product.

There are seven key principles in food safety:

- Hazard Analysis
- Critical Control Points
- Critical Limits
- Critical Control Monitoring
- Corrective Action
- Procedures
- Record Keeping

The seven HACCP principles are included in the international standard ISO 22000 FSMS 2005 and are implemented in many Food Safety Programs all around the world.

As a leading supplier to the food service industry, our products contribute to HACCP certification. We offer a full range of solutions from material handling to ingredient storage, cooking, transporting, waste management and cleaning to help you maintain food safety in your daily workflow.



Material Handling

Trust utility carts and platform trucks allow for fast and efficient handling, which ensures food quality and reduces waste.



Food Storage

Use our storage bins and containers to ensure that ingredients are dry, safe and free from external contamination.



Cooking

Food pans make it easier to distribute food and measure portions accurately.



Food Transporting

Our insulated boxes maintain their contents at a constant temperature during transport, ensuring food quality.



Waste Management

Foot-operated pedal waste bins to avoid hand contact with contaminants and prevent cross-contamination.

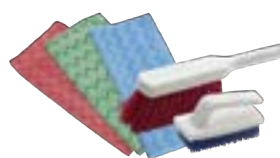

Cleaning

Microfiber cleaning tools for efficient and fast cleaning and disinfection.



FOOD MATERIAL STORAGE BINS



PRODUCT FEATURES:

1. Designed with a connected lid and a separate spoon to enable access to food materials with only one hand, for higher work efficiency.
2. Designed with a transparent lid to quickly identify the type of the contents and allows for easy inventory management.
3. Smooth walls assist easy cleaning without leaving behind any dirt.
4. All-plastic web structure ensures strength and durability.
5. The lid is easy to open for higher work efficiency.
6. Complies with NSF standards.



8411

8412

8414

| Model | Description | Dimensions | Capacity | Color | Pack |
|-------|---------------------------|----------------------|----------|-------|------|
| 8411 | Food Material Storage Bin | 74.3 × 33.4 × 75.5cm | 80L | WHT | 1 |
| 8412 | Food Material Storage Bin | 74.3 × 39.4 × 75.5cm | 100L | WHT | 1 |
| 8413 | Food Material Storage Bin | 74.3 × 45.7 × 75.5cm | 120L | WHT | 1 |
| 8414 | Spoon | 27.4 × 12.2 × 12.0cm | 1L | CLR | 6 |

STORAGE BIN LID

| | | | | | |
|------|-----------------------------|---------------------|-----|-----|---|
| 8415 | Storage Bin Lid - Fits 8411 | 73.7 × 30.7 × 4.8cm | N/A | WHT | 1 |
| 8416 | Storage Bin Lid - Fits 8412 | 73.7 × 36.8 × 4.8cm | N/A | WHT | 1 |
| 8417 | Storage Bin Lid - Fits 8413 | 73.7 × 43.7 × 4.8cm | N/A | WHT | 1 |



SHELF-TYPE RAW FOOD MATERIAL CONTAINERS



PRODUCT FEATURES:

1. A space-saving shelf storage system that provides easy access to raw food materials when stacked.
2. Specially designed sliding lid and spoon allow access to raw materials with one hand, improving work efficiency.
3. Transparent lid for quick raw materials identification and inventory management.
4. "First in, first out" design to ensure food circulation and food quality.
5. Smooth inner wall for easy cleaning without leaving any dirt.
6. Durable plastic mesh structure.
7. The lid is easy to open, improving work efficiency.
8. Complies with NSF standards.



A storage system that can still allow you to **obtain raw food materials when stacked**, providing space utilization



| Model | Description | Dimensions | Capacity | Color | Pack |
|-------|---|----------------------|----------|-------|------|
| 8418 | Shelf-type Raw Food Material Containers | 38.1 × 29.8 × 21.6cm | 10L | WHT | 1 |
| 8419 | Shelf-type Raw Food Material Containers | 59.7 × 29.2 × 42.9cm | 23L | WHT | 1 |
| 8420 | Shelf-type Raw Food Material Containers | 59.7 × 48.8 × 42.9cm | 47L | WHT | 1 |

SPOON

| | | | | | |
|------|--------------------------------------|----------------------|-------|-----|----|
| 8433 | 0.5-Cup Measuring Spoon for 8418 | 18.7 × 8.6 × 3.8cm | 0.12L | CLR | 12 |
| 8434 | 2-Cup Measuring Spoon for 8419, 8420 | 11.7 × 13.0 × 13.3cm | 0.48L | CLR | 6 |

GOODS SHELVES



PRODUCT FEATURES:

1. Designed for storage of frozen, refrigerated or dry goods.
2. Structural foam molding ensures strength and durability.
3. The hollow pad offers maximized ventilation for perishable or dry goods.
4. The pad height meets NSF standards.
5. 4491 and 4493 Lock catches can lock shelves together for better stability.

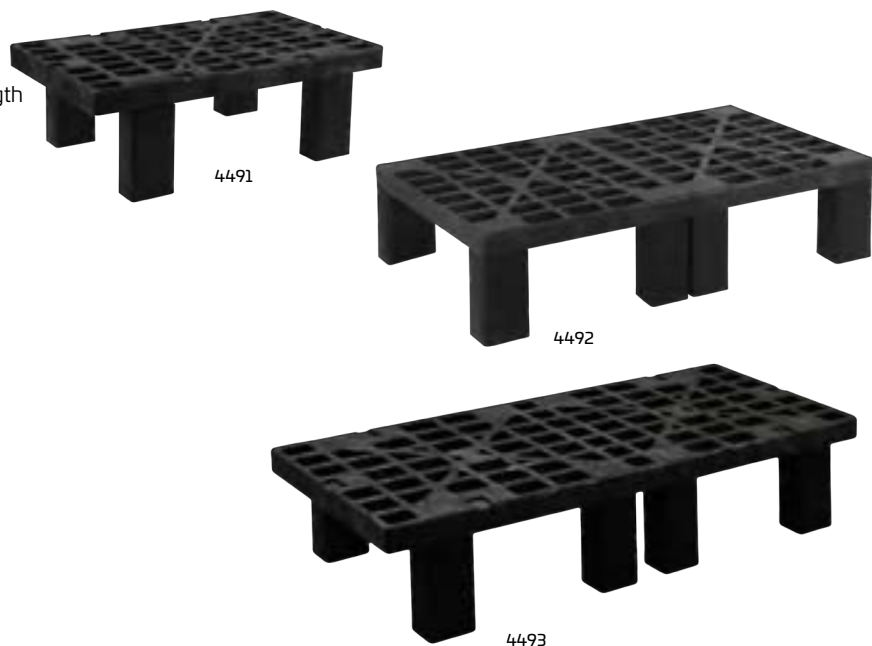

Lock catches can lock goods shelves together for better stability

| Model | Description | Dimensions | Load | Color | Pack |
|-------|-------------|-----------------------|--------|-------|------|
| 4491 | Goods Shelf | 91.0 × 53.3 × 30.5cm | 680kg | BLA | 1 |
| 4492 | Goods Shelf | 122.0 × 61.0 × 30.5cm | 900kg | BLA | 1 |
| 4493 | Goods Shelf | 152.0 × 53.3 × 30.5cm | 1360kg | BLA | 1 |

THOR® FOOD STORAGE BOXES



PRODUCT FEATURES:

1. A must-to-have container for storage and moving.
2. Ribs on the bottom prevents damage when dragged.
3. Ergonomic handles offer a comfortable grip and help prevent hand injuries.
4. Comes with a tight lid. An ideal choice for the storage of food.
5. Complies with European food safety standards and NSF standards.
6. Combine with dollies to carry heavy loads quickly and conveniently.



3011

3012

| Model | Description | Dimensions | Capacity | Color | Pack |
|-------|---------------------------|----------------------|----------|-------------------------------------|------|
| 3011 | Food Storage Box with Lid | 70.8 × 43.4 × 27.2cm | 53L | BLUE, GRAY, GRN, RED, YEL, WHT, CLR | 6 |
| 3012 | Food Storage Box with Lid | 70.8 × 43.4 × 38.4cm | 75L | BLUE, GRAY, GRN, RED, YEL, WHT, CLR | 6 |
| 4483 | Totes Trolley | 63.0 × 43.5 × 18.5cm | N/A | BLA | 1 |

THOR® STACKABLE FOOD STORAGE BINS



PRODUCT FEATURES:

1. For cost-effective storage and transportation.
2. Fits 120 × 100cm pallets with no overhang.
3. Nestable for efficient storage and transport.
4. Stackable with and without lids.
5. All-plastic construction will not rust, dent, chip, or peel.
6. Rounded corners and smooth surfaces are easy to clean.
7. Complies with the requirements of NSF #2.



3021/3023

3021/3022/3023



Stackable to save storage space

| Model | Description | Dimensions | Capacity | Color | Pack |
|-------|----------------------------|----------------------|----------|--------------------------|------|
| 3021 | Stackable Food Storage Bin | 59.2 × 39.2 × 27.0cm | 40L | BLUE, GRN, RED, YEL, WHT | 6 |
| 3022 | Stackable Food Storage Bin | 59.2 × 39.2 × 36.0cm | 55L | BLUE, GRN, RED, YEL, WHT | 6 |
| 3023 | Lid for 3021/3022 | 60.0 × 40.0 × 3.3cm | N/A | BLUE, GRN, RED, YEL, WHT | 6 |

THOR® SQUARE FOOD CONTAINERS



PRODUCT FEATURES:

1. Square shape offers up to 27% more capacity than round containers.
2. Designed with an ergonomic handle for a smooth and comfortable grip.
3. Reinforced rims add strength and durability.
4. Thick walls up to 4 mm add strength and durability.
5. Bottom hand grips of 30 mm width assist in emptying.
6. Tight fitting lids help protect the contents.
7. Square dollies are available to ensure easy mobility and maneuverability of heavy loads.



| Model | Description | Dimensions | Capacity | Color | Pack |
|-------|----------------------------------|----------------------|----------|-------|------|
| 1231 | THOR® Square Food Container | 54.6 × 54.6 × 57.2cm | 100L | WHT | 6 |
| 1233 | THOR® Square Food Container | 59.7 × 59.7 × 73.0cm | 150L | WHT | 4 |
| 1812 | THOR® Square Dolly for 1231/1233 | 43.8 × 15.9cm | N/A | BLA | 2 |
| TOPS | | | | | |
| 1661 | THOR® Lid for 1231 | 55.9 × 55.9 × 5.1cm | N/A | WHT | 6 |
| 1663 | THOR® Lid for 1233 | 61.0 × 61.0 × 5.1cm | N/A | WHT | 4 |

LARGE FOOD CONTAINERS



PRODUCT FEATURES:

1. Suitable for delivering and storing raw food materials.
2. Rotomolded, industrial-grade strength, transports heavy loads with ease.
3. Metal frame provides durable support.



| Model | Description | Dimensions | Load | Color | Pack |
|-------|-----------------------------------|-----------------------|-------|-------|------|
| 4710 | 0.2 m ³ Large Food Box | 98.0×72.0×76.0cm | 135kg | WHT | 2 |
| 4711 | 0.3 m ³ Large Food Box | 114.5 × 75.0 × 88.0cm | 180kg | WHT | 2 |
| 4714 | 0.4 m ³ Large Food Box | 117.0 × 84.0 × 86.0cm | 230kg | WHT | 2 |
| 4715 | 0.5 m ³ Large Food Box | 125.5 × 92.0 × 94.0cm | 230kg | WHT | 2 |

THOR. FRESH FRUITS AND VEGETABLES STORAGE BINS WITH LID AND CART



PRODUCT FEATURES:

1. An ideal solution for storage, washing, drying and to maintain the flavor of fresh fruits and vegetables.
2. Designed with an in-built tank to collect water flowing through the filter disc.
3. Equipped with a handy detachable cart for easily transporting the bin from an unloading area to the cleaning or cold storage areas.
4. Accompanied with a tightly-fit lid to keep Fruits and vegetables fresh and clean.
5. Seamless construction and smooth interior walls ensure easy cleaning.
6. For storage of oranges, strawberries, tomatoes and other Fruits and vegetables.



8421

| Model | Description | Dimensions | Capacity | Color | Pack |
|-------|--|---------------|----------|-------|------|
| 8421 | Fresh Fruits and Vegetables Storage Bin with a Lid and a Cart Storage Box with Lid | 57.2 × 85.1cm | 75L | WHT | 1 |
| 8422 | Fresh Fruits and Vegetables Storage Bin with a Lid and a Cart Storage Box with Lid | 63.5 × 97.8cm | 121L | WHT | 1 |

THOR. ICE BUCKETS



PRODUCT FEATURES:

1. Ensures safe delivery of ice.
2. All-plastic construction will not rust, chip, or peel; resists dents.
3. Comes with an ergonomic rounded handle providing a comfortable grip.
4. Reinforced rim adds to strength and durability.
5. Bottom hand-grips of 30 mm width assist in emptying.
6. Bucket surface is printed with the name of the contents for easy recognition.
7. Complies with NSF #2 inspection standards.



8432

| Model | Description | Dimensions | Capacity | Color | Pack |
|-------|-------------|---------------|----------|-------|------|
| 8431 | Ice Bucket | 40.0 × 44.0cm | 38L | WHT | 6 |
| 8432 | Ice Bucket | 49.0 × 57.0cm | 75L | WHT | 6 |





FOOD PANS



PRODUCT FEATURES:

1. Makes preparing, cooking, serving and storing effortless.
2. No Bisphenol A, effectively preventing food safety risks.
3. Resistant to rust, dent, twist, odor and cross contamination.
4. Materials are inert reducing the potential for chemical or acid reactions.
5. Effectively prevent cross-contamination.
6. Non-stick feature makes cleaning easier.
7. Complies with the standards of EN 631-1.
8. Complies with the requirements of NSF #2.

COLD FOOD PANS

PRODUCT FEATURES:

1. Lessens the work load and operating costs for preparation, freezing, baking and steaming.
2. Temperature rated: -40°C to 100°C.
3. Steam table and microwave safe, not for use with an open flame.
4. Not as cool to touch as metal.

HOT FOOD PANS

PRODUCT FEATURES:

1. Lessens the work load and costs of operation over preparation, freezing, baking and steaming.
2. Temperature rated: -40°C to 190°C.
3. Steam table well and microwave safe, not for use open flame.
4. Cooler to the touch than metal.

tritan™
from eastman

Tritan™ is a new generation of copolyester from the Eastman company having passed FDA certification.

1. Eastman Tritan does not contain Bisphenol A (BPA). BPA is not and has never been an ingredient or by-product of the production of Eastman Tritan™.
2. Eastman Tritan is transparent with a crystalline luster, light transmittance is greater than 90%, while haze is less than 1%.
3. Eastman Tritan is a tough and durable material that can maintain functional and aesthetic integrity over a long product life. Eastman Tritan compares favorably with PC in notched Izod impact tests. At 1/4" thickness, PC demonstrates low energy absorption and brittle failure, while Eastman Tritan continues to demonstrate high energy absorption (exceeding 15 ft-lb/in.) and ductile behavior.
4. Eastman Tritan has a higher glass transition temperature (Tg) than traditional copolyesters, which can provide a greater ability to withstand higher temperatures in dishwashers and other environments.

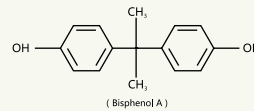

Bisphenol A (BPA), is used to synthesise PC and epoxy resin in industry.

BPA is an environmental health concern due to its widespread exposure as well as its potential toxicity. BPA is an endocrine disruptor which acts as an estrogen mimic. Evidence suggests that BPA affects circulating hormone levels, cardiovascular health, obesity, reproductive health in both males and females, hormone-driven cancers and neurobehavioral development in children. ⁽¹⁾

On Oct 18, 2008 Canada announced that bisphenol A is toxic chemical and became the first country in the world to rank it as such and prohibit from use PC food containers which contain bisphenol A. Norway, the United States, Sweden and other European and American developed countries also gradually began to ban the use of BPA in food containers.

(1) Ellen M. Wells, in Encyclopedia of Environmental Health (Second Edition), 2019

Food Pan Construction



Food Pan Layout

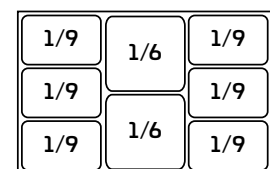
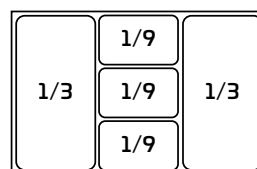
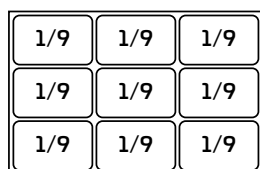
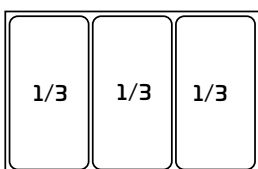
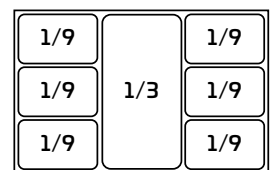
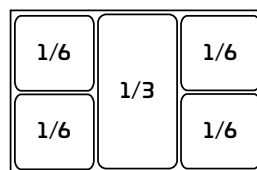
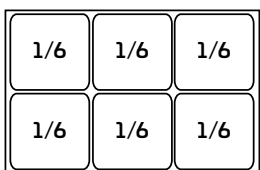
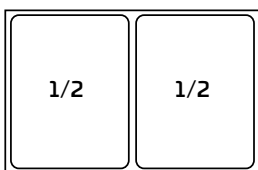
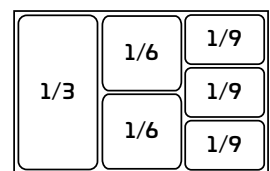
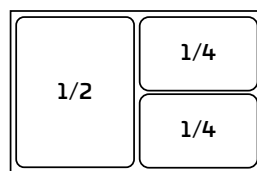
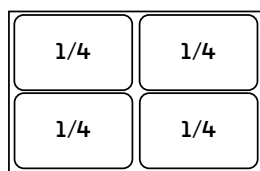
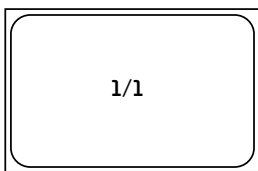

GN 1/1 FOOD PAN

| Size | Depth | Capacity | Cold Food Pan | | Hot Food Pan | | Case Pack |
|-------------|--------|----------|---------------|-------|--------------|------------|-----------|
| | | | Model | Color | Model | Color | |
| 530 × 325mm | 65 mm | 8.5L | 8451 | CLR | 8811 | AMBER, BLA | 6 |
| | 100 mm | 13.0L | 8452 | CLR | 8812 | AMBER, BLA | 6 |
| | 150 mm | 19.5L | 8453 | CLR | 8813 | AMBER, BLA | 6 |
| | 200 mm | 25.7L | 8454 | CLR | | | 6 |

GN 1/2 FOOD PAN

| Size | Depth | Capacity | Cold Food Pan | | Hot Food Pan | | Case Pack |
|-------------|--------|----------|---------------|-------|--------------|------------|-----------|
| | | | Model | Color | Model | Color | |
| 325 × 265mm | 65 mm | 3.8L | 8461 | CLR | 8821 | AMBER, BLA | 6 |
| | 100 mm | 6.0L | 8462 | CLR | 8822 | AMBER, BLA | 6 |
| | 150 mm | 8.8L | 8463 | CLR | 8823 | AMBER, BLA | 6 |
| | 200 mm | 10.8L | 8464 | CLR | | | 6 |

GN 1/3 FOOD PAN

| Size | Depth | Capacity | Cold Food Pan | | Hot Food Pan | | Case Pack |
|-------------|--------|----------|---------------|-------|--------------|------------|-----------|
| | | | Model | Color | Model | Color | |
| 325 × 176mm | 65 mm | 2.5L | 8471 | CLR | 8831 | AMBER, BLA | 6 |
| | 100 mm | 3.8L | 8472 | CLR | 8832 | AMBER, BLA | 6 |
| | 150 mm | 5.1L | 8473 | CLR | 8833 | AMBER, BLA | 6 |
| | 200 mm | 7.0L | 8474 | CLR | | | 6 |

GN 1/4 FOOD PAN

| Size | Depth | Capacity | Cold Food Pan | | Hot Food Pan | | Case Pack |
|-------------|--------|----------|---------------|-------|--------------|------------|-----------|
| | | | Model | Color | Model | Color | |
| 265 × 162mm | 65 mm | 1.6L | 8481 | CLR | 8841 | AMBER, BLA | 6 |
| | 100 mm | 2.4L | 8482 | CLR | 8842 | AMBER, BLA | 6 |
| | 150 mm | 3.8L | 8483 | CLR | 8843 | AMBER, BLA | 6 |

GN 1/6 FOOD PAN

| Size | Depth | Capacity | Cold Food Pan | | Hot Food Pan | | Case Pack |
|-------------|--------|----------|---------------|-------|--------------|------------|-----------|
| | | | Model | Color | Model | Color | |
| 176 × 162mm | 65 mm | 1.1L | 8491 | CLR | 8851 | AMBER, BLA | 6 |
| | 100 mm | 1.6L | 8492 | CLR | 8852 | AMBER, BLA | 6 |
| | 150 mm | 2.4L | 8493 | CLR | 8853 | AMBER, BLA | 6 |

GN 1/9 FOOD PAN

| Size | Depth | Capacity | Cold Food Pan | | Hot Food Pan | | Case Pack |
|-------------|--------|----------|---------------|-------|--------------|------------|-----------|
| | | | Model | Color | Model | Color | |
| 176 × 108mm | 65 mm | 0.6L | 8497 | CLR | 8861 | AMBER, BLA | 6 |
| | 100 mm | 0.8L | 8498 | CLR | 8862 | AMBER, BLA | 6 |

LIDS WITH HANDLE



PRODUCT FEATURES:

1. Molded stable handles.
2. No Bisphenol A, effectively preventing food safety risks.
3. Resistant to rust, dents and twisting.
4. Cold food pan cover temperature rated: -40°C to 100°C.
5. Hot food pan cover temperature rated: -40°C to 190°C.
6. Complies with EN 631-1 standards.
7. Complies with the requirements of NSF #2.

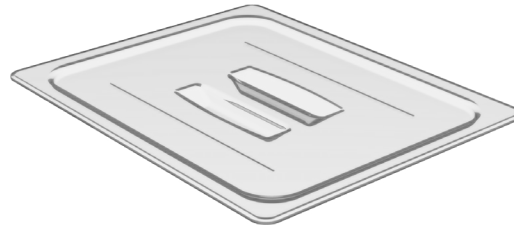

8465

| Fits Pan | Cold Food Pan Cover | | Hot Food Pan Cover | | Case Pack |
|---------------------------|---------------------|-------|--------------------|-------|-----------|
| | Model | Color | Model | Color | |
| GN1/1 530 × 325 mm | 8455 | CLR | 8814 | AMBER | 6 |
| GN1/2 325 × 265 mm | 8465 | CLR | 8824 | AMBER | 6 |
| GN1/3 325 × 176 mm | 8475 | CLR | 8834 | AMBER | 6 |
| GN1/4 265 × 162 mm | 8484 | CLR | 8844 | AMBER | 6 |
| GN1/6 176 × 162 mm | 8494 | CLR | 8854 | AMBER | 6 |

LIDS WITH OPENING AND HANDLE



PRODUCT FEATURES:

1. Molded stable handles.
2. No Bisphenol A, effectively preventing food safety risks.
3. Resistant to rust, dents and twisting.
4. Opening for kitchen utensils for a cleaner more organised kitchen.
5. Cold food pan cover temperature rated: -40°C to 100°C.
6. Hot food pan cover temperature rated: -40°C to 190°C.
7. Complies with EN 631-1 standards.
8. Complies with the requirements of NSF #2.

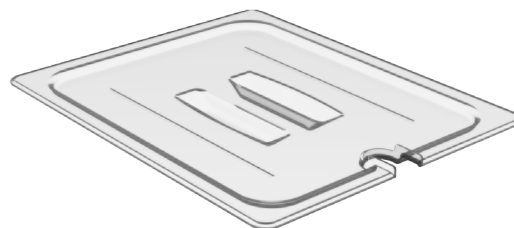

8466

| Fits Pan | Cold Food Pan Cover | | Hot Food Pan Cover | | Case Pack |
|---------------------------|---------------------|-------|--------------------|-------|-----------|
| | Model | Color | Model | Color | |
| GN1/1 530 × 325 mm | 8456 | CLR | 8815 | AMBER | 6 |
| GN1/2 325 × 265 mm | 8466 | CLR | 8825 | AMBER | 6 |
| GN1/3 325 × 176 mm | 8476 | CLR | 8835 | AMBER | 6 |
| GN1/4 265 × 162 mm | 8485 | CLR | 8845 | AMBER | 6 |
| GN1/6 176 × 162 mm | 8495 | CLR | 8855 | AMBER | 6 |

FLAT LIDS



PRODUCT FEATURES:

1. Fits any plate size.
2. No Bisphenol A, Effectively preventing food safety risks.
3. Resistant to rust, dents and twisting.
4. Cold food pan cover temperature rated: -40°C to 100°C.
5. Hot food pan cover temperature rated: -40°C to 190°C.
6. Complies with EN 631-1 standards.
7. Complies with the requirements of NSF #2.



8467

| Fits Pan | Cold Food Pan Cover | | Hot Food Pan Cover | | Case Pack |
|---------------------------|---------------------|-------|--------------------|-------|-----------|
| | Model | Color | Model | Color | |
| GN1/1 530 × 325 mm | 8457 | CLR | 8816 | AMBER | 6 |
| GN1/2 325 × 265 mm | 8467 | CLR | 8826 | AMBER | 6 |
| GN1/3 325 × 176 mm | 8477 | CLR | 8836 | AMBER | 6 |
| GN1/4 265 × 162 mm | 8486 | CLR | 8846 | AMBER | 6 |
| GN1/6 176 × 162 mm | 8496 | CLR | 8856 | AMBER | 6 |
| GN1/9 176 × 108 mm | 8499 | CLR | 8863 | AMBER | 6 |

DRAIN TRAYS



PRODUCT FEATURES:

1. Suitable for the preparation of vegetables, frozen seafood, meat thawing and storage.
2. No Bisphenol A, effectively preventing food safety risks.
3. Resistant to rust, dents and twisting.
4. Cold drain tray temperature rated: -40°C to 100°C.
5. Hot drain tray cover temperature rated: -40°C to 190°C.
6. Complies with the requirements of NSF #2.

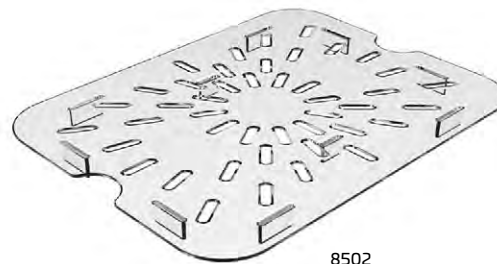

8502

| Fits Pan | Cold Drain Tray | | Hot Drain Tray | | Case Pack |
|---------------------------|-----------------|-------|----------------|-------|-----------|
| | Model | Color | Model | Color | |
| GN1/1 530 × 325 mm | 8501 | CLR | 8506 | AMBER | 6 |
| GN1/2 325 × 265 mm | 8502 | CLR | 8507 | AMBER | 6 |
| GN1/3 325 × 176 mm | 8503 | CLR | 8508 | AMBER | 6 |
| GN1/4 265 × 162 mm | 8504 | CLR | 8509 | AMBER | 6 |
| GN1/6 176 × 162 mm | 8505 | CLR | 8510 | AMBER | 6 |





COLD FOOD PANS

PRODUCT FEATURES:

1. Makes food preparation, cooking, serving and storing effortless.
2. Break resistant, won't rust, dent or twist.
3. Reduces potential of chemical or acid reactions and resulting food contaminations.
4. Effectively avoids cross-contamination.
5. Dishwasher and microwave safe.
6. Quieter, not as cool to touch and with less condensation than metal.
7. Non-stick surfaces for easy food debris removal and cleaning.
8. Complies with EN 631-1 standards.
9. Comply with the requirements of NSF #2.



POLYCARBONATE (PC) COLD FOOD PANS

PRODUCT FEATURES:

1. Significantly less cost than stainless steel.
2. Crystal clear.
3. Temperature rated: -40°C to 99.8°C.



POLYPROPYLENE (PP) COLD FOOD PANS

PRODUCT FEATURES:

1. The most economical option.
2. Semi-transparent, allows contents to be visible.
3. Temperature rated: -40°C to 70°C.
4. BPA free



PC

PP

GN 1/1 FOOD PAN

| Size | Depth | Capacity | PC Cold Food Pan | | PP Cold Food Pan | | Case Pack |
|-------------|--------|----------|------------------|-------|------------------|-------|-----------|
| | | | Model | Color | Model | Color | |
| 530 × 325mm | 65 mm | 8.5L | 8911 | CLR | 8731 | CLR | 6 |
| | 100 mm | 13.0L | 8912 | CLR | 8732 | CLR | 6 |
| | 150 mm | 19.5L | 8913 | CLR | 8733 | CLR | 6 |
| | 200 mm | 25.7L | 8914 | CLR | 8734 | CLR | 6 |

GN 1/2 FOOD PAN

| Size | Depth | Capacity | PC Cold Food Pan | | PP Cold Food Pan | | Case Pack |
|-------------|--------|----------|------------------|-------|------------------|-------|-----------|
| | | | Model | Color | Model | Color | |
| 325 × 265mm | 65 mm | 3.8L | 8921 | CLR | 8741 | CLR | 6 |
| | 100 mm | 6.0L | 8922 | CLR | 8742 | CLR | 6 |
| | 150 mm | 8.8L | 8923 | CLR | 8743 | CLR | 6 |
| | 200 mm | 10.8L | 8924 | CLR | 8744 | CLR | 6 |

GN 1/3 FOOD PAN

| Size | Depth | Capacity | PC Cold Food Pan | | PP Cold Food Pan | | Case Pack |
|-------------|--------|----------|------------------|-------|------------------|-------|-----------|
| | | | Model | Color | Model | Color | |
| 325 × 176mm | 65 mm | 2.5L | 8931 | CLR | 8751 | CLR | 6 |
| | 100 mm | 3.8L | 8932 | CLR | 8752 | CLR | 6 |
| | 150 mm | 5.1L | 8933 | CLR | 8753 | CLR | 6 |
| | 200 mm | 7.0L | 8934 | CLR | 8754 | CLR | 6 |

GN 1/4 FOOD PAN

| Size | Depth | Capacity | PC Cold Food Pan | | PP Cold Food Pan | | Case Pack |
|-------------|--------|----------|------------------|-------|------------------|-------|-----------|
| | | | Model | Color | Model | Color | |
| 265 × 162mm | 65 mm | 1.6L | 8941 | CLR | 8761 | CLR | 6 |
| | 100 mm | 2.4L | 8942 | CLR | 8762 | CLR | 6 |
| | 150 mm | 3.8L | 8943 | CLR | 8763 | CLR | 6 |

GN 1/6 FOOD PAN

| Size | Depth | Capacity | PC Cold Food Pan | | PP Cold Food Pan | | Case Pack |
|-------------|--------|----------|------------------|-------|------------------|-------|-----------|
| | | | Model | Color | Model | Color | |
| 176 × 162mm | 65 mm | 1.1L | 8951 | CLR | 8771 | CLR | 6 |
| | 100 mm | 1.6L | 8952 | CLR | 8772 | CLR | 6 |
| | 150 mm | 2.4L | 8953 | CLR | 8773 | CLR | 6 |

GN 1/9 FOOD PAN

| Size | Depth | Capacity | PC Cold Food Pan | | PP Cold Food Pan | | Case Pack |
|-------------|--------|----------|------------------|-------|------------------|-------|-----------|
| | | | Model | Color | Model | Color | |
| 176 × 108mm | 65 mm | 0.6L | 8961 | CLR | 8781 | CLR | 6 |
| | 100 mm | 0.8L | 8962 | CLR | 8782 | CLR | 6 |

LIDS WITH HANDLE



PRODUCT FEATURES:

1. Molded construction handles are stable.
2. No Bisphenol A, effectively preventing food safety risks.
3. Resistant to rust, dent and twist.
4. Cold food pan cover temperature rated: -40°C to 99.8°C.
5. Complies with the standards of EN 631-1.
6. Complies with the requirements of NSF #2.



8954

| Fits Pan | PC Cold Food Pan Cover | | PP Cold Food Pan Cover | | Case Pack |
|---------------------------|------------------------|-------|------------------------|-------|-----------|
| | Model | Color | Model | Color | |
| GN1/1 530 × 325 mm | 8915 | CLR | 8735 | CLR | 6 |
| GN1/2 325 × 265 mm | 8925 | CLR | 8745 | CLR | 6 |
| GN1/3 325 × 176 mm | 8935 | CLR | 8755 | CLR | 6 |
| GN1/4 265 × 162 mm | 8944 | CLR | 8764 | CLR | 6 |
| GN1/6 176 × 162 mm | 8954 | CLR | 8774 | CLR | 6 |

LIDS WITH ENTRY AND HANDLE



PRODUCT FEATURES:

1. Molded construction handles are stable.
2. No Bisphenol A, effectively preventing food safety risks.
3. Resistant to rust, dent and twist.
4. Gaps design allows the kitchen utensils in the food dish and make sure the kitchen clean.
5. Cold food pan cover temperature rated: -40°C to 99.8°C.
6. Complies with the standards of EN 631-1.
7. Complies with the requirements of NSF #2.



8955

| Fits Pan | PC Cold Food Pan Cover | | PP Cold Food Pan Cover | | Case Pack |
|---------------------------|------------------------|-------|------------------------|-------|-----------|
| | Model | Color | Model | Color | |
| GN1/1 530 × 325 mm | 8916 | CLR | 8736 | CLR | 6 |
| GN1/2 325 × 265 mm | 8926 | CLR | 8746 | CLR | 6 |
| GN1/3 325 × 176 mm | 8936 | CLR | 8756 | CLR | 6 |
| GN1/4 265 × 162 mm | 8945 | CLR | 8765 | CLR | 6 |
| GN1/6 176 × 162 mm | 8955 | CLR | 8775 | CLR | 6 |

FLAT LID



PRODUCT FEATURES:

1. Fits any plate size.
2. No Bisphenol A, Effectively preventing food safety risks.
3. Resistant to rust, dent and twist.
4. Cold food pan cover temperature rated: -40°C to 99.8°C.
5. Complies with the standards of EN 631-1.
6. Complies with the requirements of NSF #2.



8963

| Fits Pan | PC Cold Food Pan Cover | | PP Cold Food Pan Cover | | Case Pack |
|---------------------------|------------------------|-------|------------------------|-------|-----------|
| | Model | Color | Model | Color | |
| GN1/1 530 × 325 mm | 8917 | CLR | 8737 | CLR | 6 |
| GN1/2 325 × 265 mm | 8927 | CLR | 8747 | CLR | 6 |
| GN1/3 325 × 176 mm | 8937 | CLR | 8757 | CLR | 6 |
| GN1/4 265 × 162 mm | 8946 | CLR | 8766 | CLR | 6 |
| GN1/6 176 × 162 mm | 8956 | CLR | 8776 | CLR | 6 |
| GN1/9 176 × 108 mm | 8963 | CLR | 8783 | CLR | 6 |

DRAIN TRAYS



PRODUCT FEATURES:

1. Suitable for the preparation of vegetables, frozen seafood, meat thawing and storage.
2. No Bisphenol A, effectively preventing food safety risks.
3. Resistant to rust, dent and twist.
4. Cold drain tray temperature rated: -40°C to 99.8°C.
5. Complies with the requirements of NSF #2.



8975

| Fits Pan | PC Cold Drain Tray | | PP Cold Drain Tray | | Case Pack |
|---------------------------|--------------------|-------|--------------------|-------|-----------|
| | Model | Color | Model | Color | |
| GN1/1 530 × 325 mm | 8971 | CLR | 8791 | CLR | 6 |
| GN1/2 325 × 265 mm | 8972 | CLR | 8792 | CLR | 6 |
| GN1/3 325 × 176 mm | 8973 | CLR | 8793 | CLR | 6 |
| GN1/4 265 × 162 mm | 8974 | CLR | 8794 | CLR | 6 |
| GN1/6 176 × 162 mm | 8975 | CLR | 8795 | CLR | 6 |

ROUND STORAGE CONTAINERS



PRODUCT FEATURES:

1. Stores food safely and conveniently.
2. Two models available with white polyethylene or semi-clear polypropylene, for better visibility.
3. Easy-to-clean cover.
4. Suitable for temperatures between -34°C and 100°C.
5. Complies with the requirements of NSF 3A and NSF 2.



Semi-clear Polypropylene Round Storage Containers

| Model | Description | Dimensions | Capacity | Color | Pack |
|-------|-----------------------------------|---------------|----------|-------|------|
| 8311 | Round Storage Container | 21.6 × 10.2cm | 1.9L | STRAN | 12 |
| 8312 | Round Storage Container | 21.6 × 19.7cm | 3.8L | STRAN | 12 |
| 8313 | Round Storage Container | 25.4 × 19.4cm | 5.7L | STRAN | 12 |
| 8314 | Round Storage Container | 25.4 × 27.0cm | 7.6L | STRAN | 12 |
| 8315 | Round Storage Container | 33.3 × 20.6cm | 11.4L | STRAN | 6 |
| 8316 | Round Storage Container | 33.3 × 30.2cm | 17.0L | STRAN | 6 |
| 8317 | Round Storage Container | 33.3 × 35.6cm | 20.8L | STRAN | 6 |
| 8318 | Round Storage Container with Bail | 33.3 × 35.6cm | 20.8L | STRAN | 6 |



Polyethylene Round Storage Containers

| Model | Description | Dimensions | Capacity | Color | Pack |
|-------|-----------------------------------|---------------|----------|-------|------|
| 8321 | Round Storage Container | 21.6 × 10.2cm | 1.9L | WHT | 12 |
| 8322 | Round Storage Container | 21.6 × 19.7cm | 3.8L | WHT | 12 |
| 8323 | Round Storage Container | 25.4 × 19.4cm | 5.7L | WHT | 12 |
| 8324 | Round Storage Container | 25.4 × 27.0cm | 7.6L | WHT | 12 |
| 8325 | Round Storage Container | 33.3 × 20.6cm | 11.4L | WHT | 6 |
| 8326 | Round Storage Container | 33.3 × 30.2cm | 17.0L | WHT | 6 |
| 8327 | Round Storage Container | 33.3 × 35.6cm | 20.8L | WHT | 6 |
| 8328 | Round Storage Container with Bail | 33.3 × 35.6cm | 20.8L | WHT | 6 |

LIDS



PRODUCT FEATURES:

1. Double wall insulated lock is easy to use and keeps food fresh.
2. Unique way to hold, easy and stable.
3. Taggable with customized notes.
4. Three sizes available to fit up to 8 different kinds of containers.

Specially designed lid is convenient to open



| Model | Description | Dimensions | Capacity | Color | Pack |
|-------|--|--------------|----------|----------|------|
| 8331 | Lid for 8311, 8312, 8321, 8322 | 22.2 × 2.2cm | N/A | YEL | 12 |
| 8332 | Lid for 8313, 8314, 8323, 8324 | 26.0 × 2.5cm | N/A | YEL, NAT | 12 |
| 8333 | Lid for 8315, 8316, 8317, 8318, 8325, 8326, 8327, 8328 | 34.0 × 3.0cm | N/A | YEL, NAT | 6 |



FIRMGR® STORAGE SYSTEM



Trust offers two shelving storage systems for the hospitality industry comprising the Firmgre® and Firmgre® Modus storage systems. No matter your space or budget, we have a perfect solution for you! By choosing our storage system, you can achieve maximum cost savings, efficient use of space and meet hygiene, food safety and functionality standards.

1. Made from materials that are rust and corrosion-free.
2. Suitable for all kinds of environments, and can be used at temperatures between -40°C and 90°C.
3. Impervious to water, chemicals, salts, acid, alkali and humidity.
4. Maximizes storage space with shelves that are designed to share posts without losing overall load capacity.
5. Specially designed internal slots on the posts create a neat appearance and make the posts safer to hold.
6. Cleaning can be completed quickly without affecting storage capacity and utility.
7. Each shelf can be easily and individually adjusted to accommodate different items.



FIRMIGRE CONFIGURATIONS

STARTER KIT

Complete set to build one 4-shelf unit:

2 Post Kits 4 Shelf Kits

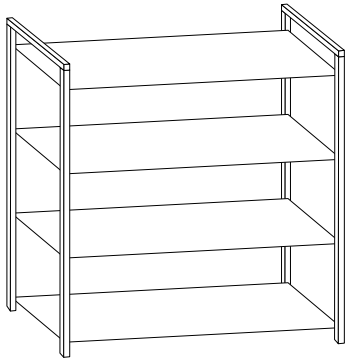

EXTENSION KIT

Extension set to add to 4-shelf units:

1 Post Kit 4 Shelf Kits

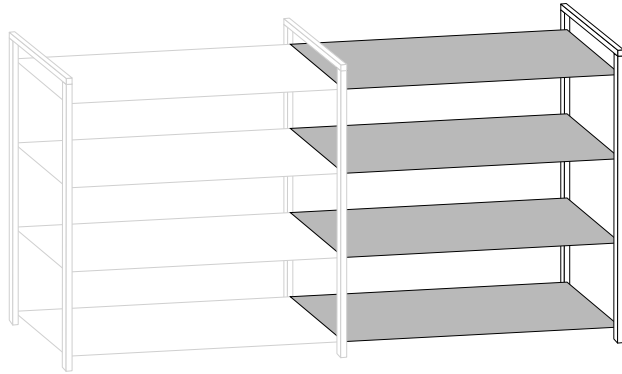

CORNER UNIT

(STARTER KIT + EXTENSION)

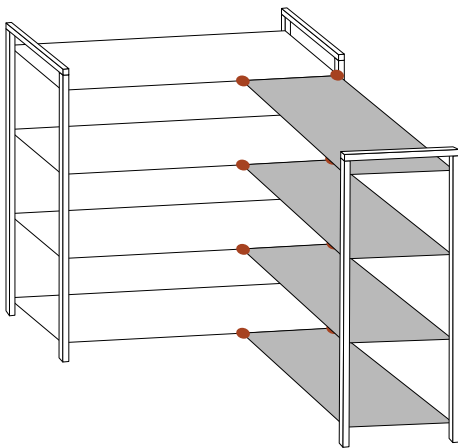

U-SHAPE UNIT

(2 STARTER KITS + 4 SHELF KITS)

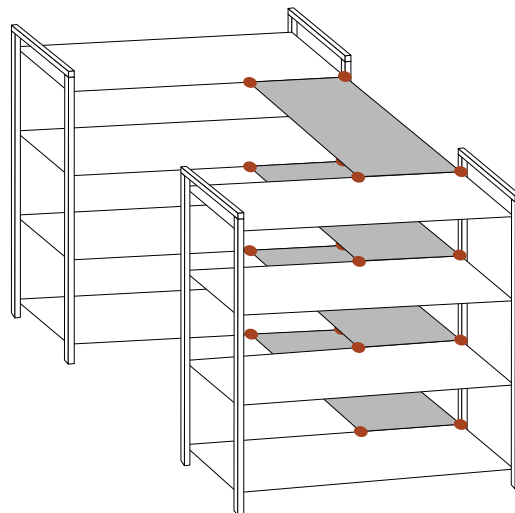

T-SHAPE UNIT

(STARTER KIT + EXTENSION)

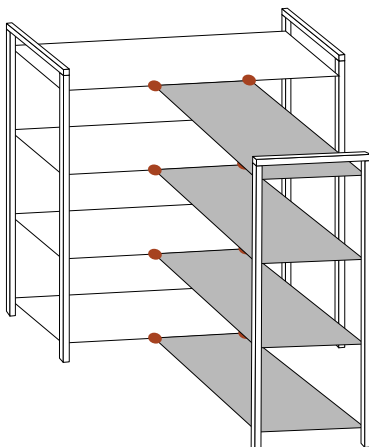

● CORNER CONNECTORS

Connect the shelves with Corner Connectors to turn difficult areas into more accessible storage spaces.

FIRMGRE® SYSTEM COMPARISON

| | FIRMGRE® SYSTEM | FIRMGRE® MODUS SYSTEM |
|--|--|---|
| STORAGE AREA | Regular loading and unloading of medium to heavy products for high volume food service operations. 5-7 deliveries per week Wet storage small freezer, cooler, warewashing area Dry storage bulk food, food service equipment, tableware/cutlery, linen products, goods | Regular loading and unloading of light to medium products for medium volume food service operations. 3-4 deliveries per week. Wet storage small freezer, cooler, warewashing area Dry storage bulk food, food service equipment, tableware/cutlery, linen products, goods |
| RECOMMENDED MARKET SEGMENTS | Hotels and entertainment venues, restaurants, fast food outlets, schools, colleges and universities, medical institutions, military institutions, convention centers, cruise ships, catering venues, corporate cafeteria, convenience stores and grocery stores | Hotels and entertainment venues, restaurants, fast food outlets, schools, colleges and universities, medical institutions, convention centers, catering venues, corporate cafeteria, convenience stores and cafes |
| LOAD CAPACITY (Please refer to the diagrams on the next page for detail) | Fixed shelf (Based on 610-1220mm length) 350kg load capacity per partition. Each shelf has a load capacity of 1400kg. Mobile shelves each shelf has a load capacity of 340kg. Corner, U-shaped and T-shaped shelves (Based on 610-1220mm length) 180kg on the 3 top partitions, 275kg on the bottom partition, 815kg per shelf. | Fixed shelf (Based on 760-910mm length) 300kg load capacity per partition. Each shelf has a load capacity of 1200kg. Corner, U-shaped and T-shaped shelves (Based on 760-1220mm length) 135kg on the 3 top partitions, 205kg on the bottom partition, 610kg per shelf. |
| SHELF LENGTH | 610, 760, 910, 1070, 1220, 1380, 1530, 1830, 1980mm | 760, 910, 1070, 1220, 1380, 1530mm |
| SHELF DEPTH | 360, 460, 540, 610mm | 460, 540, 610mm |
| POST HEIGHT | Fixed rack 1630, 1830, 2140mm Mobile rack 1780, 1980mm (including casters) | Fixed rack 1630, 1830, 2140mm |
| MOBILE RACK | Yes | No |

FREE FIRMGRE® DESIGN SERVICE

Trust offers a free shelving system design service to prepare your business's most cost-effective and space maximizing storage solution. Our consultants will plan a system design that addresses your space and storage needs.

Please email info@trustcommercial.com with the following information. We will provide you with a proposal within 2 working days.

- Project Name
- Storage room type (freezer/refrigerator/ambient)
- Room size (L x W x H)
- Entrance location and dimensions
- Obstacles (condenser/pipe)
- Other preferences/requirements



MICROBAN®

MICROBAN® ANTI-MICROBIAL PROTECTION TECHNOLOGIES

Microban® anti-microbial technologies provide full protection by working to destroy or inhibit the growth and reproduction of bacteria, mold and mildew.

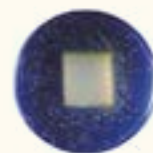

Plastic sample without Microban® anti-microbial ingredients.



Plastic sample with Microban® anti-microbial ingredients.

*Microban® is the registered owner of Microban® trademark, and reserves all the rights. Microban® anti-microbial protection is not designed to protect users against disease causing micro-organisms and is not a substitute for routine cleaning.



Easy clean vented shelf panels
Rust free and dishwasher safe



Maximises storage space
Share posts without losing overall load capacity



Easy to adjust
Shelves can be easily adjusted to suit the height of loads

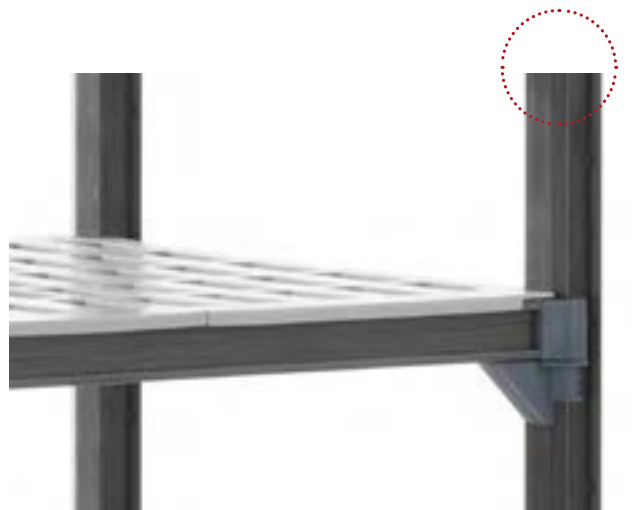

Internal slots on posts
Creates a neat appearance, easy to clean, safer to hold



Rust and corrosion-free
Save on cost of repair and replacement



Easy adjustment
Each shelf can be easily adjusted to suit different stored products



OVERALL LENGTH OF UNITS

STARTER KIT with EXTENSION

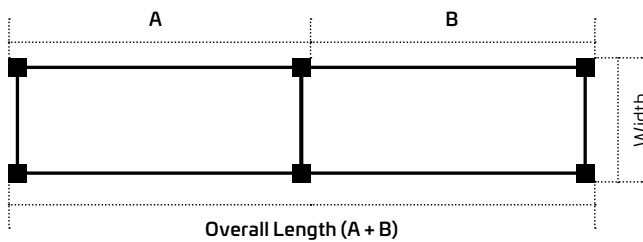



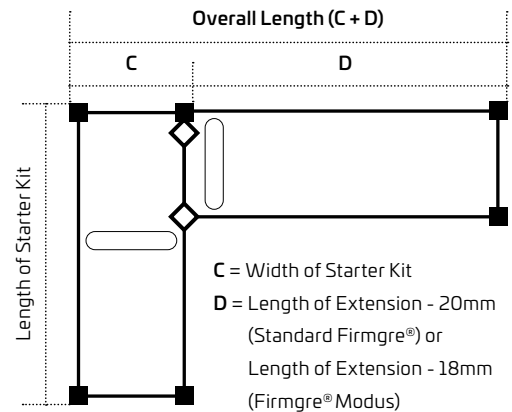

- A = Length of Starter Kit
- B = Length of Extension - 48mm (Standard Firmgre®) or
Length of Extension - 36mm (Firmgre® Modus)

CORNER UNIT

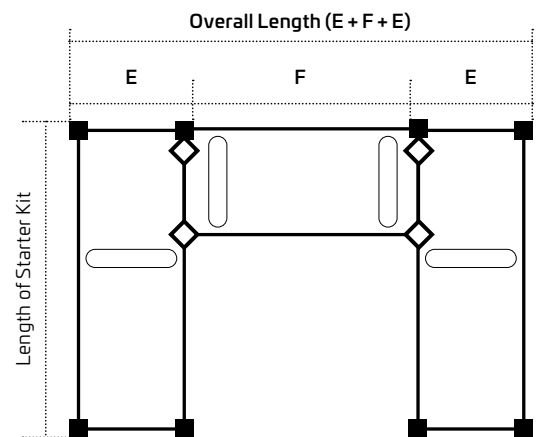

U-SHAPED UNIT



-  **Post:** Share posts to maximise storage space without losing overall load capacity
-  **Corner Connector:** A set of two Corner Connectors required per connecting point.
-  **Dunnage Stand:** 1 Dunnage Stand required for each section of shelves.



WEIGHT CAPACITY

STANDARD FIRMGRE® SHELVES

SINGLE UNIT
610 - 1220mm

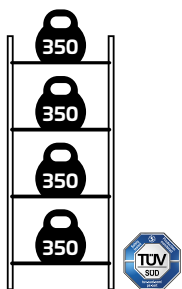

1400kg max per unit

SINGLE UNIT
1380 - 1530mm

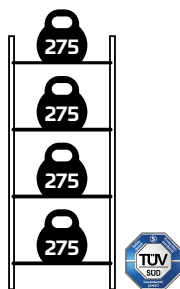

1100kg max per unit

SINGLE UNIT
1830 - 1980mm

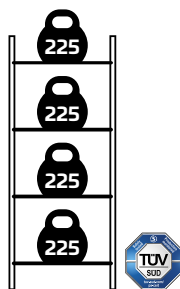

900kg max per unit

SINGLE UNIT
1380 - 1530mm
(Dunnage stand)

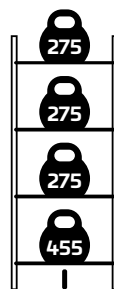

1280kg max per unit

CORNER UNIT
610 - 1220mm
(2 Dunnage stands)

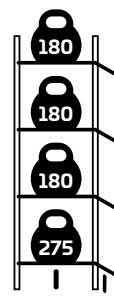

815kg max per unit

MOBILE UNIT
910 - 1220mm

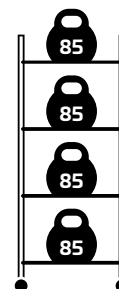

340kg max per unit*

FIRMGRE® MODUS SHELVES

SINGLE UNIT
760 - 910mm

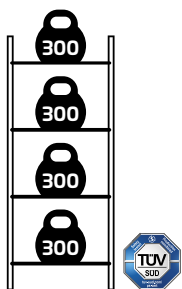

1200kg max per unit

SINGLE UNIT
1070 - 1220mm

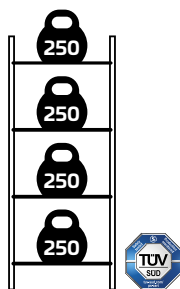

1000kg max per unit

SINGLE UNIT
1380 - 1530mm

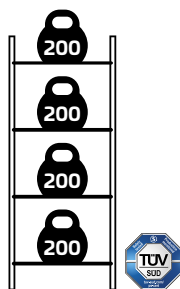

800kg max per unit

SINGLE UNIT
1380 - 1530mm
(Dunnage stand)

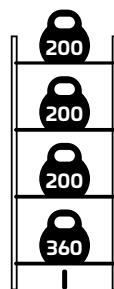

960kg max per unit

CORNER UNIT
760 - 1220mm
(2 Dunnage stands)

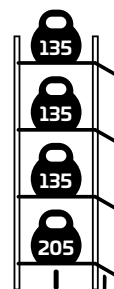

610kg max per unit

* The maximum load of the mobile unit is 340kg, limited by the weight capacity of the castors.

FIRMGRE® STARTER KITS & EXTENSIONS

FIRMGRE® Storage Kits come in various configurations to fit any size area.

The 4-shelf Stationary Starter Kits include 2 Stationary Posts and 4 Shelf Kits.

The 4-shelf Stationary Extension Kits come with 1 Stationary Posts and 4 Shelf Kits.

4-SHELF STATIONARY STARTER KIT - 360MM WIDE



| | | LENGTH | | | | | | | | |
|--------|--------|----------|----------|----------|----------|----------|----------|----------|----------|----------|
| | | 610mm | 760mm | 910mm | 1070mm | 1220mm | 1380mm | 1530mm | 1830mm | 1980mm |
| HEIGHT | 1630mm | AX142464 | AX143064 | AX143664 | AX144264 | AX144864 | AX145464 | AX146064 | AX147264 | AX147864 |
| | 1830mm | AX142472 | AX143072 | AX143672 | AX144272 | AX144872 | AX145472 | AX146072 | AX147272 | AX147872 |
| | 2140mm | AX142484 | AX143084 | AX143684 | AX144284 | AX144884 | AX145484 | AX146084 | AX147284 | AX147884 |

4-SHELF STATIONARY EXTENSION KIT - 360MM WIDE



| | | LENGTH | | | | | | | | |
|--------|--------|----------|----------|----------|----------|----------|----------|----------|----------|----------|
| | | 610mm | 760mm | 910mm | 1070mm | 1220mm | 1380mm | 1530mm | 1830mm | 1980mm |
| HEIGHT | 1630mm | AE142464 | AE143064 | AE143664 | AE144264 | AE144864 | AE145464 | AE146064 | AE147264 | AE147864 |
| | 1830mm | AE142472 | AE143072 | AE143672 | AE144272 | AE144872 | AE145472 | AE146072 | AE147272 | AE147872 |
| | 2140mm | AE142484 | AE143084 | AE143684 | AE144284 | AE144884 | AE145484 | AE146084 | AE147284 | AE147884 |

4-SHELF STATIONARY STARTER KIT - 460MM WIDE



| | | LENGTH | | | | | | | | |
|--------|--------|----------|----------|----------|----------|----------|----------|----------|----------|----------|
| | | 610mm | 760mm | 910mm | 1070mm | 1220mm | 1380mm | 1530mm | 1830mm | 1980mm |
| HEIGHT | 1630mm | AX182464 | AX183064 | AX183664 | AX184264 | AX184864 | AX185464 | AX186064 | AX187264 | AX187864 |
| | 1830mm | AX182472 | AX183072 | AX183672 | AX184272 | AX184872 | AX185472 | AX186072 | AX187272 | AX187872 |
| | 2140mm | AX182484 | AX183084 | AX183684 | AX184284 | AX184884 | AX185484 | AX186084 | AX187284 | AX187884 |

4-SHELF STATIONARY EXTENSION KIT - 460MM WIDE



| | | LENGTH | | | | | | | | |
|--------|--------|----------|----------|----------|----------|----------|----------|----------|----------|----------|
| | | 610mm | 760mm | 910mm | 1070mm | 1220mm | 1380mm | 1530mm | 1830mm | 1980mm |
| HEIGHT | 1630mm | AE182464 | AE183064 | AE183664 | AE184264 | AE184864 | AE185464 | AE186064 | AE187264 | AE187864 |
| | 1830mm | AE182472 | AE183072 | AE183672 | AE184272 | AE184872 | AE185472 | AE186072 | AE187272 | AE187872 |
| | 2140mm | AE182484 | AE183084 | AE183684 | AE184284 | AE184884 | AE185484 | AE186084 | AE187284 | AE187884 |

4-SHELF STATIONARY STARTER KIT - 540MM WIDE



| | | LENGTH | | | | | | | | |
|--------|--------|----------|----------|----------|----------|----------|----------|----------|----------|----------|
| | | 610mm | 760mm | 910mm | 1070mm | 1220mm | 1380mm | 1530mm | 1830mm | 1980mm |
| HEIGHT | 1630mm | AX212464 | AX213064 | AX213664 | AX214264 | AX214864 | AX215464 | AX216064 | AX217264 | AX217864 |
| | 1830mm | AX212472 | AX213072 | AX213672 | AX214272 | AX214872 | AX215472 | AX216072 | AX217272 | AX217872 |
| | 2140mm | AX212484 | AX213084 | AX213684 | AX214284 | AX214884 | AX215484 | AX216084 | AX217284 | AX217884 |

4-SHELF STATIONARY EXTENSION KIT - 540MM WIDE



| | | LENGTH | | | | | | | | |
|--------|--------|----------|----------|----------|----------|----------|----------|----------|----------|----------|
| | | 610mm | 760mm | 910mm | 1070mm | 1220mm | 1380mm | 1530mm | 1830mm | 1980mm |
| HEIGHT | 1630mm | AE212464 | AE213064 | AE213664 | AE214264 | AE214864 | AE215464 | AE216064 | AE217264 | AE217864 |
| | 1830mm | AE212472 | AE213072 | AE213672 | AE214272 | AE214872 | AE215472 | AE216072 | AE217272 | AE217872 |
| | 2140mm | AE212484 | AE213084 | AE213684 | AE214284 | AE214884 | AE215484 | AE216084 | AE217284 | AE217884 |

4-SHELF STATIONARY STARTER KIT - 610MM WIDE



| | | LENGTH | | | | | | | | |
|--------|--------|----------|----------|----------|----------|----------|----------|----------|----------|----------|
| | | 610mm | 760mm | 910mm | 1070mm | 1220mm | 1380mm | 1530mm | 1830mm | 1980mm |
| HEIGHT | 1630mm | AX242464 | AX243064 | AX243664 | AX244264 | AX244864 | AX245464 | AX246064 | AX247264 | AX247864 |
| | 1830mm | AX242472 | AX243072 | AX243672 | AX244272 | AX244872 | AX245472 | AX246072 | AX247272 | AX247872 |
| | 2140mm | AX242484 | AX243084 | AX243684 | AX244284 | AX244884 | AX245484 | AX246084 | AX247284 | AX247884 |

4-SHELF STATIONARY EXTENSION KIT - 610MM WIDE



| | | LENGTH | | | | | | | | |
|--------|--------|----------|----------|----------|----------|----------|----------|----------|----------|----------|
| | | 610mm | 760mm | 910mm | 1070mm | 1220mm | 1380mm | 1530mm | 1830mm | 1980mm |
| HEIGHT | 1630mm | AE242464 | AE243064 | AE243664 | AE244264 | AE244864 | AE245464 | AE246064 | AE247264 | AE247864 |
| | 1830mm | AE242472 | AE243072 | AE243672 | AE244272 | AE244872 | AE245472 | AE246072 | AE247272 | AE247872 |
| | 2140mm | AE242484 | AE243084 | AE243684 | AE244284 | AE244884 | AE245484 | AE246084 | AE247284 | AE247884 |

FIRMGRE® MOBILE STORAGE KITS

FIRMGRE® Mobile Storage Kits are designed to move between dry storage areas and walk-in fridges quickly and easily. They are made from the same high quality materials as the FIRMGRE® stationary shelves. The weight capacity is 340kg per unit.

The FIRMGRE® 4-Shelf Mobile Shelving Kits come with 2 Mobile Posts and 4 Shelf kits.

4-SHELF MOBILE STORAGE KIT - 360MM WIDE

| | | LENGTH | | | | |
|--------|--------|----------|----------|----------|----------|----------|
| | | 910mm | 1070mm | 1220mm | 1380mm | 1530mm |
| HEIGHT | 1780mm | AM143670 | AM144270 | AM144870 | AM145470 | AM146070 |
| | 1980mm | AM143678 | AM144278 | AM144878 | AM145478 | AM146078 |

4-SHELF MOBILE STORAGE KIT - 460MM WIDE

| | | LENGTH | | | | |
|--------|--------|----------|----------|----------|----------|----------|
| | | 910mm | 1070mm | 1220mm | 1380mm | 1530mm |
| HEIGHT | 1780mm | AM183670 | AM184270 | AM184870 | AM185470 | AM186070 |
| | 1980mm | AM183678 | AM184278 | AM184878 | AM185478 | AM186078 |

4-SHELF MOBILE STORAGE KIT - 540MM WIDE

| | | LENGTH | | | | |
|--------|--------|----------|----------|----------|----------|----------|
| | | 910mm | 1070mm | 1220mm | 1380mm | 1530mm |
| HEIGHT | 1780mm | AM213670 | AM214270 | AM214870 | AM215470 | AM216070 |
| | 1980mm | AM213678 | AM214278 | AM214878 | AM215478 | AM216078 |

4-SHELF MOBILE STORAGE KIT - 610MM WIDE

| | | LENGTH | | | | |
|--------|--------|----------|----------|----------|----------|----------|
| | | 910mm | 1070mm | 1220mm | 1380mm | 1530mm |
| HEIGHT | 1780mm | AM243670 | AM244270 | AM244870 | AM245470 | AM246070 |
| | 1980mm | AM243678 | AM244278 | AM244878 | AM245478 | AM246078 |

FIRMFIX PARTS & ACCESSORY

Create a custom storage unit with these parts and accessories to suit different requirements.

STATIONARY POST KIT



| | | WIDTH | | | |
|--------|--------|--------|--------|--------|--------|
| | | 360mm | 460mm | 540mm | 610mm |
| HEIGHT | 1630mm | XY1464 | XY1864 | XY2164 | XY2464 |
| | 1830mm | XY1472 | XY1872 | XY2172 | XY2472 |
| | 2140mm | XY1484 | XY1884 | XY2184 | XY2484 |

MOBILE POST KIT



| | | WIDTH | | | |
|--------|--------|--------|--------|--------|--------|
| | | 360mm | 460mm | 540mm | 610mm |
| HEIGHT | 1780mm | XM1470 | XM1870 | XM2170 | XM2470 |
| | 1980mm | XM1478 | XM1878 | XM2178 | XM2478 |

DUNNAGE STAND



| | | WIDTH | | | |
|--------|-------|--------|--------|--------|--------|
| | | 360mm | 460mm | 540mm | 610mm |
| HEIGHT | 165mm | XY1400 | XY1800 | XY2100 | XY2400 |



Dunnage Stands help to increase the stability and bearing capacity of the bottom shelf and can be applied to any unit. It is recommended to apply Dunnage Stands to all storage units 1380mm wide or longer. They are required for all corner units, U-shape units and units designated for carrying heavy products.

SHELF KIT



| | | LENGTH | | | | | | | | |
|-------|-------|--------|--------|--------|--------|--------|--------|--------|--------|--------|
| | | 610mm | 760mm | 910mm | 1070mm | 1220mm | 1380mm | 1530mm | 1830mm | 1980mm |
| WIDTH | 360mm | XX1424 | XX1430 | XX1436 | XX1442 | XX1448 | XX1454 | XX1460 | XX1472 | XX1478 |
| | 460mm | XX1824 | XX1830 | XX1836 | XX1842 | XX1848 | XX1854 | XX1860 | XX1872 | XX1878 |
| | 540mm | XX2124 | XX2130 | XX2136 | XX2142 | XX2148 | XX2154 | XX2160 | XX2172 | XX2178 |
| | 610mm | XX2424 | XX2430 | XX2436 | XX2442 | XX2448 | XX2454 | XX2460 | XX2472 | XX2478 |



FITTING ACCESSORIES



Specially designed **Corner Connectors** to maximize storage spaces

- 1 Corner Connector Set is required per shelf on Corner units.
- 2 Corner Connector Sets are required per shelf for U-shape units.



Easy **clip-on plastic tags** to identify stored items



Easy **clip-on plastic tags** to identify stored items



The shelving unit should be fixed to the wall with the **wall fastener** when necessary to increase the stability. The wall fasteners are made from stainless steel. (screws included)



Fix the posts to the floor with the **Seismic Foot** when necessary for a more stable base. The Seismic foot is made from stainless steel. (screws included)



Swivel Castors are suitable for all areas



Swivel Castors with Brake are suitable for all areas

| Model | Description | Dimensions | Capacity | Color | Pack |
|--------|---------------------------|---------------------|----------|-------|------|
| XX0001 | Corner Connector | 5.3 × 4.6 × 3.7cm | N/A | GRAY | 1 |
| XX0002 | Identification Tag 15cm | 15.0 × 3.4 × 0.7cm | N/A | GRAY | 12 |
| XX0003 | Identification Tag 7.6cm | 7.6 × 3.4 × 0.7cm | N/A | GRAY | 12 |
| XX0004 | Wall Fastener | 13.0 × 4.0 × 5.3cm | N/A | SS | 4 |
| XX0005 | Seismic Foot | 11.0 × 9.9 × 8.4cm | N/A | SS | 4 |
| XX0006 | Swivel Castors | 12.0 × 22.5 × 5.3cm | N/A | GRAY | 1 |
| XX0007 | Swivel Castors with Brake | 14.5 × 22.5 × 5.3cm | N/A | GRAY | 1 |



FIRMGRE® MODUS STORAGE SYSTEM



FIRMGRE® Modus shelving is made of super strong composite material. They are lighter and stronger than ordinary metal shelving. The storage system is specially designed for storing light to medium-sized items in the freezer, refrigerator or utensil cleaning area.

1. Never rust and corrosion, lighter and stronger than ordinary metal shelves.
2. Suitable for all kinds of environments, and can be used at temperatures between -40°C and 90°C.
3. Won't be affected by water, chemicals, salts, acid, alkali and humidity.
4. Maximizes storage space with shelves that are designed to share posts without losing overall load capacity.
5. Cleaning can be completed quickly without affecting storage capacity and utility.
6. Each shelf can be easily and individually adjusted to accommodate different items.



MODUS 4-SHELF STATIONARY STARTER KIT - 460MM WIDE

| | | LENGTH | | | | | |
|--------|--------|----------|----------|----------|----------|----------|----------|
| | | 760mm | 910mm | 1070mm | 1220mm | 1380mm | 1530mm |
| HEIGHT | 1630mm | BX183064 | BX183664 | BX184264 | BX184864 | BX185464 | BX186064 |
| | 1830mm | BX183072 | BX183672 | BX184272 | BX184872 | BX185472 | BX186072 |
| | 2140mm | BX183084 | BX183684 | BX184284 | BX184884 | BX185484 | BX186084 |

MODUS 4-SHELF STATIONARY EXTENSION KIT - 460MM WIDE

| | | LENGTH | | | | | |
|--------|--------|----------|----------|----------|----------|----------|----------|
| | | 760mm | 910mm | 1070mm | 1220mm | 1380mm | 1530mm |
| HEIGHT | 1630mm | BE183064 | BE183664 | BE184264 | BE184864 | BE185464 | BE186064 |
| | 1830mm | BE183072 | BE183672 | BE184272 | BE184872 | BE185472 | BE186072 |
| | 2140mm | BE183084 | BE183684 | BE184284 | BE184884 | BE185484 | BE186084 |

MODUS 4-SHELF STATIONARY STARTER KIT - 540MM WIDE

| | | LENGTH | | | | | |
|--------|--------|----------|----------|----------|----------|----------|----------|
| | | 760mm | 910mm | 1070mm | 1220mm | 1380mm | 1530mm |
| HEIGHT | 1630mm | BX213064 | BX213664 | BX214264 | BX214864 | BX215464 | BX216064 |
| | 1830mm | BX213072 | BX213672 | BX214272 | BX214872 | BX215472 | BX216072 |
| | 2140mm | BX213084 | BX213684 | BX214284 | BX214884 | BX215484 | BX216084 |

MODUS 4-SHELF STATIONARY EXTENSION KIT - 540MM WIDE

| | | LENGTH | | | | | |
|--------|--------|----------|----------|----------|----------|----------|----------|
| | | 760mm | 910mm | 1070mm | 1220mm | 1380mm | 1530mm |
| HEIGHT | 1630mm | BE213064 | BE213664 | BE214264 | BE214864 | BE215464 | BE216064 |
| | 1830mm | BE213072 | BE213672 | BE214272 | BE214872 | BE215472 | BE216072 |
| | 2140mm | BE213084 | BE213684 | BE214284 | BE214884 | BE215484 | BE216084 |

MODUS 4-SHELF STATIONARY STARTER KIT - 610MM WIDE

| | | LENGTH | | | | | |
|--------|--------|----------|----------|----------|----------|----------|----------|
| | | 760mm | 910mm | 1070mm | 1220mm | 1380mm | 1530mm |
| HEIGHT | 1630mm | BX243064 | BX243664 | BX244264 | BX244864 | BX245464 | BX246064 |
| | 1830mm | BX243072 | BX243672 | BX244272 | BX244872 | BX245472 | BX246072 |
| | 2140mm | BX243084 | BX243684 | BX244284 | BX244884 | BX245484 | BX246084 |

MODUS 4-SHELF STATIONARY EXTENSION KIT - 610MM WIDE

| | | LENGTH | | | | | |
|--------|--------|----------|----------|----------|----------|----------|----------|
| | | 760mm | 910mm | 1070mm | 1220mm | 1380mm | 1530mm |
| HEIGHT | 1630mm | BE243064 | BE243664 | BE244264 | BE244864 | BE245464 | BE246064 |
| | 1830mm | BE243072 | BE243672 | BE244272 | BE244872 | BE245472 | BE246072 |
| | 2140mm | BE243084 | BE243684 | BE244284 | BE244884 | BE245484 | BE246084 |

FITTING MODUS STORAGE SYSTEM ACCESSORIES



Specially designed **Corner Connectors** to maximize storage spaces

- 1 Corner Connector Set is required per shelf on Corner units.
- 2 Corner Connector Sets are required per shelf for U-shape units.



Easy **clip-on plastic tags** to identify stored items



Easy **clip-on plastic tags** to identify stored items



The shelving unit should be fixed to the wall with the **wall fastener** when necessary to increase the stability. The wall fasteners are made from stainless steel. (screws included)



Fix the posts to the floor with the **Seismic Foot** when necessary for a more stable base. The Seismic foot is made from stainless steel. (screws included)

| Model | Description | Dimensions | Capacity | Color | Pack |
|--------|--------------------------------|--------------------|----------|-------|------|
| XB0001 | Modus Corner Connector | 4.7 × 4.2 × 3.0cm | N/A | GRAY | 1 |
| XB0002 | Modus Identification Tag 15cm | 15.0 × 2.5 × 0.8cm | N/A | GRAY | 12 |
| XB0003 | Modus Identification Tag 7.6cm | 7.6 × 2.5 × 0.8cm | N/A | GRAY | 12 |
| XB0004 | Modus Wall Fastener | 13.0 × 4.0 × 4.6cm | N/A | SS | 4 |
| XB0005 | Modus Seismic Foot | 9.9 × 9.8 × 8.4cm | N/A | SS | 4 |



FIRMGR[®] MODUS PARTS & ACCESSORY

Create a custom storage unit with these parts and accessories to suit different requirements.

MODUS STATIONARY POST KIT



| | | WIDTH | | |
|--------|--------|--------|--------|--------|
| | | 460mm | 540mm | 610mm |
| HEIGHT | 1630mm | XA1864 | XA2164 | XA2464 |
| | 1830mm | XA1872 | XA2172 | XA2472 |
| | 2140mm | XA1884 | XA2184 | XA2484 |

MODUS DUNNAGE STAND



| | | WIDTH | | |
|--------|-------|--------|--------|--------|
| | | 460mm | 540mm | 610mm |
| HEIGHT | 170mm | XA1800 | XA2100 | XA2400 |
| | 270mm | XA1801 | XA2101 | XA2401 |



Dunnage Stands help to increase the stability and bearing capacity of the bottom shelf and can be applied to any unit. It is recommended to apply Dunnage Stands to all storage units 1380mm wide or longer. They are required for all corner units, U-shape units and units designated for carrying heavy products.

MODUS SHELF KIT



| | | LENGTH | | | | | |
|-------|-------|--------|--------|--------|--------|--------|--------|
| | | 760mm | 910mm | 1070mm | 1220mm | 1380mm | 1530mm |
| WIDTH | 460mm | XB1830 | XB1836 | XB1842 | XB1848 | XB1854 | XB1860 |
| | 540mm | XB2130 | XB2136 | XB2142 | XB2148 | XB2154 | XB2160 |
| | 610mm | XB2430 | XB2436 | XB2442 | XB2448 | XB2454 | XB2460 |





INSULATED BOXES



PRODUCT FEATURES:

1. Suitable for the preservation of food and beverages.
2. Keeps food and beverages hot or cold without electricity for 12 hours.
3. Specialized interior resists cold, heat and corrosion.
4. Passed relevant tests for compliance with FDA 21 CFR PART 177.1520.
5. Easy to carry with a comfortable handle.
6. 8715 Pull rod design for easy delivery and higher efficiency.



8711

8712

8713



Extendable handle for easier more efficient delivery



8714



8715

| Model | Description | Dimensions | Capacity | Color | Pack |
|-------|-----------------------------|----------------------|----------|-------|------|
| 8711 | Insulated Box | 31.5 × 21.0 × 28.0cm | 8L | RED | 1 |
| 8712 | Insulated Box | 46.7 × 30.5 × 38.3cm | 25L | RED | 1 |
| 8713 | Insulated Box | 54.5 × 33.5 × 38.5cm | 38L | RED | 1 |
| 8714 | Insulated Box | 61.5 × 39.0 × 44.5cm | 55L | RED | 1 |
| 8715 | Pull Rod Type Insulated Box | 52.0 × 30.0 × 47.0cm | 48L | RED | 1 |



INSULATED BOTTLES



PRODUCT FEATURES:

1. Suitable for the preservation of food and beverages.
2. Keeps food and beverages hot or cold without electricity for 12 hours.
3. Specialized interior resists cold, heat and corrosion.
4. Passed relevant tests for compliance with FDA 21 CFR PART 177.1520.
5. Easy to use with the comfortable handle.



8721

| Model | Description | Dimensions | Capacity | Color | Pack |
|-------|------------------|----------------------|----------|-------|------|
| 8721 | Insulated Bottle | 21.2 × 17.0 × 28.5cm | 2.5L | RED | 1 |

COLD DRINK COOLBOXES



PRODUCT FEATURES:

1. Suitable for the preservation of food and beverages.
2. Keeps food and beverages hot or cold without electricity for 12 hours.
3. Specialized interior resists cold, heat and corrosion.
4. Passed relevant tests for compliance with FDA 21 CFR PART 177.1520.
5. Comfortable handles on both sides for easy operation.
6. High quality valve and perfectly airtight.



8701



8702



8703

| Model | Description | Dimensions | Capacity | Color | Pack |
|-------|--------------------|----------------------|----------|-------|------|
| 8701 | Cold Drink Coolbox | 30.5 × 34.0 × 30.0cm | 10L | RED | 1 |
| 8702 | Cold Drink Coolbox | 40.0 × 34.0 × 48.0cm | 20L | RED | 1 |
| 8703 | Cold Drink Coolbox | 47.0 × 41.0 × 54.0cm | 55L | RED | 1 |



**INSULATED
PRODUCTS**



EXCEBOX® INSULATED FOOD CARRIERS

Trust has a large selection of food delivery equipment, providing our customers a wide range of options. We will design the optimum system to help grow your business and build a loyal following for your brand, while maintaining food safety and quality.

Ensuring food safety and quality

When it comes to food processing every second is crucial. From the first moment of food preparation right through to delivery to the customer. Every step of the way, EXCEBOX® helps to keep food at the temperature it should be, hot or cold.

EXCEBOX® Insulated Food Carriers are suitable for a range of applications such as:

- Delivery of food materials and ingredients
- Counter-top storage for pickup or delivery
- Food delivery to the end user

Keeping employees safe

EXCEBOX® Insulated Food Carriers are made from high-tech materials with an ergonomic design, enhancing workplace safety for employees. Notable features include.

- Ultra lightweight construction
- Safe and sturdy carrying straps
- Specially designed carts for transporting bulk catering orders



Thermal insulation

Keeps food hot or cold for over 4 hours.



Ultra light

Made of EPP (Expanded Polypropylene Polystyrene - an environmentally friendly high-performance foam material) making your meal delivery incredibly easy.



High structural strength

Able to bear a large load while maintaining its shape and style.



Superior cushioning

Able to withstand significant impact without damage.



Dishwasher safe



Corrosion resistance

Not affected by oil, grease and most chemicals.



100% recyclable



Compatible with GN food pans

Ensures food safety and meets HACCP requirements for storage and transportation systems.

EXCEBOX® INSULATED FOOD CARRIERS

The EXCEBOX® System is the perfect solution for catering and food service operators. The System provides excellent thermal insulation ensuring appropriate food safety. They are made of environmentally friendly, high-performance insulation - Expanded Polypropylene Polystyrene (EPP) - and are incredibly lightweight, making your meal delivery incredibly easy.

The EXCEBOX® System is an affordable solution, which offers the durability needed to cope with frequent commercial use.

- Keeps food at a safe temperature for over 4 hours.
- Perfect for storing food waiting to be picked up.
- Ideal for multiple stops or large events.
- Stackable.
- One of the most economical food transfer solutions.

Temperature Holding Performance

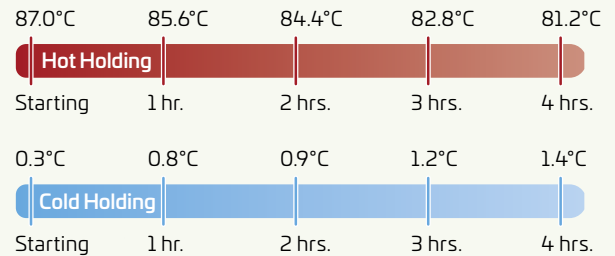

Note: Work best with food trays temperature range between 82 to 88°C.

Loading metal food trays above 120°C will damage the EXCEBOX® carrier.





FRONT-LOADING EXCEBOX®

PRODUCT FEATURES:

1. Beveled doors for easy door opening and closing.
2. Durable hinges and latches that allow the front loading EXCEBOX® to open up to 270° for easy access.
3. Built-in handles on all 4 sides, make it easy to carry.
4. Built-in condensation barrier helps stop dripping.
5. Use the built-in label area to keep plastic labels in place to easily identify contents or provide route directions.
6. Can be stacked securely to save space.



8879

Beveled doors for easy door opening and closing

Built-in handles on all 4 sides, make it easy to carry

Durable hinges and latches that allow the front loading EXCEBOX® to open up to 270° for easy access.

Built-in condensation barrier helps stop dripping



Can be stacked firmly to save space





| Model | Description | Exterior Dimensions | Interior Dimensions | Volume | Weight | Suitable For Use With | Color | Pack |
|-------|---|----------------------|----------------------|--------|--------|-----------------------|-------|------|
| 8879 | Front-Loading EXCEBOX® 47.5cm Height | 64.0 × 44.0 × 47.5cm | 53.5 × 33.0 × 37.0cm | 60.0L | 3.3kg | GN1/1 Food Pan | BLA | 1 |
| 8880 | Front-Loading EXCEBOX® 62.5cm Height | 64.0 × 44.0 × 62.5cm | 53.5 × 33.0 × 52.5cm | 86.0L | 4.0kg | GN1/1 Food Pan | BLA | 1 |
| 8881 | Front-Loading EXCEBOX® without Rail | 77.0 × 54.0 × 68.7cm | 61.5 × 41.0 × 58.5cm | 155.0L | 6.2kg | 60 × 40cm Crates | BLA | 1 |
| 8882 | Front-Loading EXCEBOX® with 6 Rails | 77.0 × 54.0 × 68.7cm | 61.5 × 41.0 × 58.5cm | 126.0L | 6.4kg | 60 × 40cm Food Tray | BLA | 1 |
| 8883 | Front-Loading EXCEBOX® with 9 Rails | 77.0 × 54.0 × 68.7cm | 61.5 × 41.0 × 58.5cm | 126.0L | 6.7kg | 60 × 40cm Food Tray | BLA | 1 |

- 8879/8880 suitable for loading GN1/1 food trays.
- 8881 is designed for loading 60 × 40cm crates; 8881 used with Adjustable Rail Kit (8890) to load both 60 × 40cm crates and food trays.
- 8882/8883 are suitable for loading 60 × 40cm food trays.



Built-in **condensation barrier** helps stop dripping



Stackable to save space



Use the **built-in label area** to keep plastic labels in place to easily identify contents or provide route directions

TOP-LOADING EXCEBOX®

PRODUCT FEATURES:

1. Internal grooves for easy loading and unloading of GN 1/1 or GN 1/2 food pans.
2. Comfortable ergonomic handles for easy and safe handling.
3. Use the built-in label area to keep plastic labels in place to easily identify contents or provide route directions.
4. Can be stacked securely to save space.



8870



| Model | Description | Exterior Dimensions | Interior Dimensions | Volume | Weight | Suitable For Use With | Color | Pack |
|-------|--|---|--|--------|--------|-----------------------------|-------|------|
| 8870 | GN1/2 EXCEBOX® 25.7cm Height | 39.0 × 33.0 × 25.7cm | 33.0 × 27.0 × 19.3cm | 16.9L | 0.7kg | GN1/2 15cm Deep Food Pan | BLA | 1 |
| 8871 | GN1/2 EXCEBOX® 31.6cm Height | 39.0 × 33.0 × 31.6cm | 33.0 × 27.0 × 25.3cm | 22.3L | 0.8kg | GN1/2 20cm Deep Food Pan | BLA | 1 |
| 8872 | GN1/2 EXCEBOX® with Carrying Handle | 39.0 × 33.0 × 31.6cm | 33.0 × 27.0 × 25.3cm | 22.3L | 0.9kg | GN1/2 20cm Deep Food Pan | BLA | 1 |
| 8873 | GN1/1 EXCEBOX® 25.7cm Height | 60.0 × 40.0 × 25.7cm | 53.8 × 33.8 × 19.3cm | 35.5L | 1.2kg | GN1/1 15cm Deep Food Pan | BLA | 1 |
| 8874 | GN1/1 EXCEBOX® 31.6cm Height | 60.0 × 40.0 × 31.6cm | 53.8 × 33.8 × 25.3cm | 46.0L | 1.3kg | GN1/1 20cm Deep Food Pan | BLA | 1 |
| 8875 | GN1/1 EXCEBOX® Stackable | TOP 60.0 × 40.0 × 18.2cm BOTTOM 53.6 × 33.6 × 10cm | TOP 53.8 × 33.8 × 15.9cm BOTTOM 50.4 × 30.2 × 9.5cm | 43.0L | 1.2kg | GN1/1 20cm Deep Food Pan | BLA | 1 |
| 8876 | GN1/1 EXCEBOX® with Ergonomic Handles | 68.0 × 40.0 × 32.1cm | 53.8 × 35.5 × 25.5cm | 46.0L | 1.4kg | GN1/1 20cm Deep Food Pan | BLA | 1 |
| 8877 | 6040 EXCEBOX® 27.0cm Height | 69.0 × 49.0 × 27.0cm | 42.5 × 62.5 × 20.5cm | 53.0L | 1.6kg | 60 × 40cm Food Tray | BLA | 1 |
| 8878 | 6040 EXCEBOX® 37.0cm Height | 69.0 × 49.0 × 37.0cm | 42.5 × 62.5 × 30.5cm | 80.0L | 1.9kg | 60 × 40cm Food Tray | BLA | 1 |



8872



8876



8878

Fits GN food
pans perfectly

EXCEBOX® ACCESSORIES



Plastic Labels - 5 Pack - Red / Yellow / Blue / Green / White (8884) are ideal for easy content identification or routing.



Comprising stainless steel frames and 2 sets of rails, the **Adjustable Rail Kit (8890)** is flexible and can fit food pans and trays of different heights.



Warmer (8887) designed to extend the hot holding time of your food.



Cooler (8885/8886) designed to extend the cold holding time of your food.



Dolly (8888/8889) specially designed to fit all EXCEBOX®.



Lid (8891) GN 1/2 lid designed to fit Top-loading EXCEBOX®.



Lid (8892) GN 1/1 lid designed to fit Top-loading EXCEBOX®.

| Model | Description | Dimensions | Suitable For Use With | Color | Pack |
|-------|-------------------------------------|----------------------|---|-------------------------------|------|
| 8884 | Plastic Labels | 8.7 x 5.0cm | All EXCEBOX® | N/A | 1 |
| 8885 | GN1/2 Cooler | 32.5 x 26.5 x 3.1cm | 8870 / 8871 / 8872 | BLUE | 1 |
| 8886 | GN1/1 Cooler | 53.0 x 32.5 x 3.1cm | 8873 / 8874 / 8875 / 8876 / 8879 / 8880 | BLUE | 1 |
| 8887 | GN1/1 Warmer | 53.0 x 32.5 x 3.1cm | 8873 / 8874 / 8875 / 8876 / 8879 / 8880 | RED | 1 |
| 8888 | Dolly | 67.6 x 43.6 x 17.3cm | 8873 / 8874 / 8875 / 8876 / 8879 / 8880 | BLA | 1 |
| 8889 | Dolly | 75.5 x 51.7 x 16.5cm | 8877 / 8878 / 8881 / 8882 / 8883 | BLA | 1 |
| 8890 | Adjustable Rail Kit | N/A | 8881 | SS | 1 |
| 8891 | GN 1/2 Lid for Top-loading EXCEBOX® | 39.0 x 33.0 x 3.6cm | 8870/8871/8872 | BLUE, YEL, GRN, RED, BLA, ORA | 6 |
| 8892 | GN 1/1 Lid for Top-loading EXCEBOX® | 60.0 x 40.0 x 3.6cm | 8873/8874/8875 | BLUE, YEL, GRN, RED, BLA, ORA | 6 |



Food Pan Configuration Examples

Top-loading

8870 / 8873



Top-loading

8871 / 8872 / 8874 / 8876



Top-loading

8875

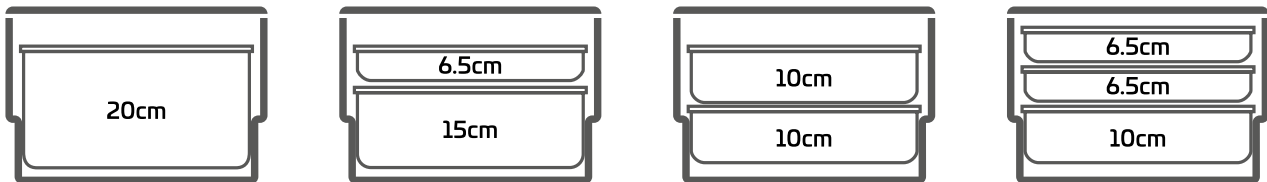

Front-loading

8879

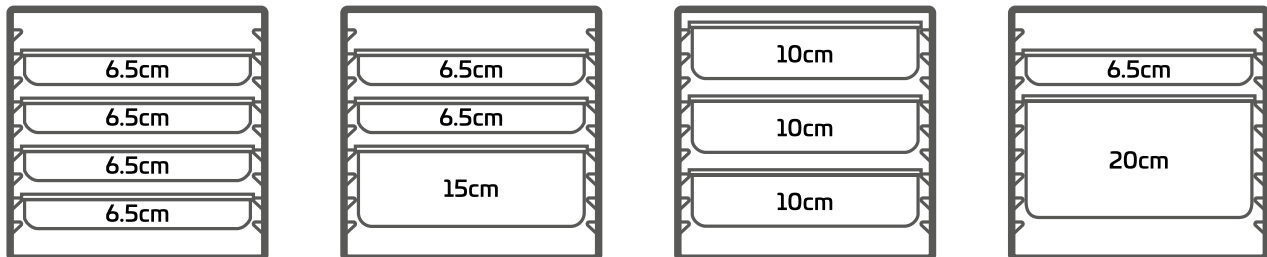

Front-loading

8880

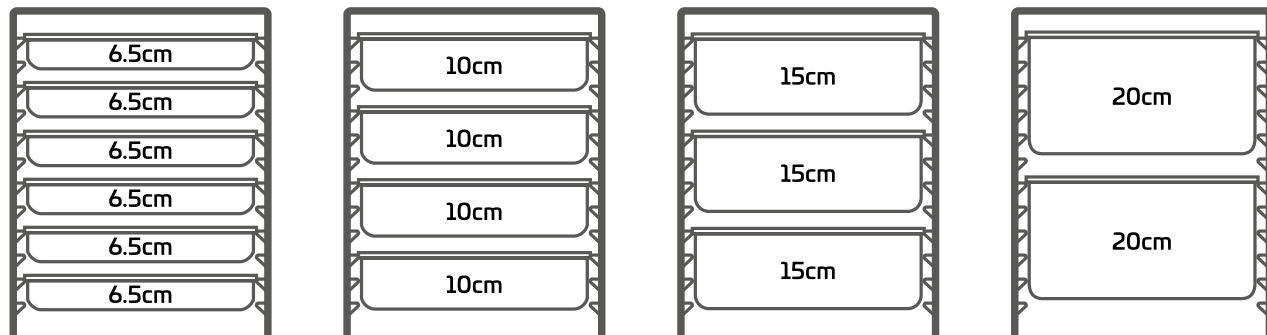



FOOD STORAGE RACKS/CARTS



PRODUCT FEATURES:

1. An effective aid for food preparation, transportation, supplying and storage.
2. Multi-purpose systems are designed to work with food trays, food boxes, and food pans up to GB, European and American standards.
3. All plastic web structure ensures strength and durability.
4. Rounded edge design won't damage walls, doors and other equipment.
5. High temperature resistant plastic structure (up to 176°C) allows for direct rack contact with oven-hot baking trays.
6. Quiet castor design and elegant appearance allow for quick restocking of food directly from the kitchen to the dining hall.
7. 12.7cm non-marking casters, two of which have braking function, offer easy maneuverability.
8. Complies with NSF # 2 inspection standards.
9. Please contact distributors for customization.



8621

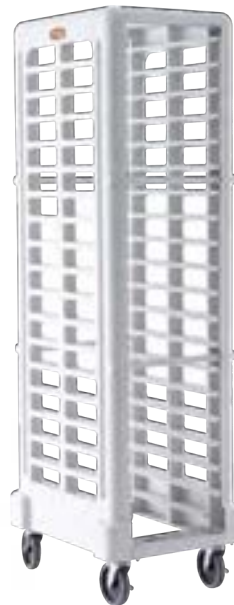

8613



8614



Rounded edge design won't damage walls, doors and other equipment



12.7cm non-marking casters, two of which have braking function, offer easy maneuverability

8613/8621 Food Cart

Front loading type
Shelf width: 33.0cm
Suitable for food box/pan size:

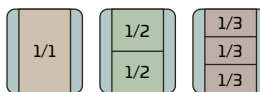

8614/8622 Food Cart

Side loading type
Shelf width: 66.4cm
Suitable for food box/pan size:

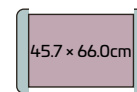

8615 Food Cart

Side loading type
Shelf width: 65.4cm
Suitable for food box/pan size:

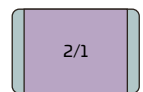

| Model | Description | Dimensions | Tray Number | Color | Pack |
|-------|------------------------|-----------------------|-------------|-----------|------|
| 8613 | Food Storage Rack/Cart | 60.3 x 47.3 x 172.4cm | 17 | BLA, OWHT | 1 |
| 8614 | Food Storage Rack/Cart | 80.6 x 60.3 x 172.4cm | 17 | BLA, OWHT | 1 |
| 8615 | Food Storage Rack/Cart | 79.6 x 60.3 x 172.4cm | 17 | BLA, OWHT | 1 |
| 8621 | Food Storage Rack/Cart | 60.3 x 47.3 x 91.8cm | 8 | BLA, OWHT | 1 |
| 8622 | Food Storage Rack/Cart | 80.6 x 60.3 x 91.8cm | 8 | BLA, OWHT | 1 |

ADJUSTABLE TRAY & DISH CARTS

PRODUCT FEATURES:

1. Stores 10.8 to 29.8cm plates and bowls.
2. Totally adjustable to fit the size of plates and bowls.
3. Structural web technology enhances resistance to tableware damage.
4. Resistant to rust, dents and scratches.
5. Optimized ergonomic handle is comfortable to use.
6. 12.5cm non-marking casters, two of which have braking function, offer easy maneuverability.
7. Rounded corners protect wall, doors and appliances.
8. Stackable for convenient storage and space saving.
9. Dust mesh included.



8651



Plate Size: Dia 24.4 to 29.8cm
4 Columns (60 each)
Total Capacity: 240



Plate Size: Dia 16.5 to 18.7cm
8 Columns (45 each)
Total Capacity: 360



2 Columns:
Dia 24.4 to 29.8cm (60 each)
4 Columns:
Dia 16.5 to 18.7cm (45 each)
Total Capacity: 300



3 Columns:
Dia 19.1 to 21.6cm (60 each)
6 Columns:
Dia 12.1 to 13.7cm (45 each)
Total Capacity: 450



3 Columns:
Dia 16.5 to 18.7cm (45 each)
8 Columns:
Dia 10.8 to 11.7cm (45 each)
Total Capacity: 495



2 Columns:
Dia 16.5 to 18.7cm (45 each)
2 Columns:
Dia 12.1 to 13.7cm (45 each)
8 Columns:
Dia 10.8 to 11.7cm (45 each)
Total Capacity: 540



Stackable for convenient storage and space saving



Four side handle is easy to operate

MICROBAN®

MICROBAN® ANTI-MICROBIAL PROTECTION TECHNOLOGIES

Microban® anti-microbial technologies provide full protection by working to destroy or inhibit the growth and reproduction of bacteria, mold and mildew.



| Model | Description | Dimensions | Capacity | Color | Pack |
|-------|---------------------------|----------------------|----------|------------------|------|
| 8651 | Adjustable Tray&Dish Cart | 68.0 × 68.0 × 81.0cm | N/A | BLA, DBRN, SGRAY | 1 |
| 8652 | Divider | 11.5 × 6.5 × 59.8cm | N/A | BLA, DBRN, SGRAY | 2 |
| 8653 | Cover | 68.5 × 68.5 × 60.0cm | N/A | CLR | 2 |

OEASY® PLATFORM TRUCKS



PRODUCT FEATURES:

1. Perfect for transporting heavy loads in any environment.
2. User friendly handles help to maneuver the cart and ensure the safety of operators.
3. Molded-in structure adds strength and durability, and prolongs the service life.
4. Textured surfaces for non-skid and safe transporting.
5. Grooves close to edges help prevent small items against from rolling out.
6. Notches on both sides are for secure latching of transported goods.
7. Flexible fixing clip helps to prevent accidental release of the handle while allowing easy disassembly.
8. Durable powder-coated steel handle.



| Model | Description | Deck Size | Dimensions | Load | Caster Type | Pack |
|-------|------------------------|----------------|------------------------|-------|------------------|------|
| 4411 | OEASY® Platform Trucks | 91.4 × 61.0cm | 101.9 × 61.0 × 100.6cm | 450kg | 15.0 × 5.0cm TPR | 1 |
| 4413 | OEASY® Platform Trucks | 121.9 × 61.0cm | 132.4 × 61.0 × 105.7cm | 900kg | 20.0 × 5.0cm TPR | 1 |

HIS® UTILITY SERVICE CARTS



PRODUCT FEATURES:

1. Versatile, functional and a workhorse in any facility.
2. Molded shelves won't rust, dent, or chip.
3. Performs multiple duties: stocking cart, turndown cart, self-serving food kiosk, mobile beverage server.
4. Sized for smaller properties or restocking.
5. Quiet, non-marking swivel casters.



| Model | Description | Dimensions | Load | Color | Pack |
|-------|---|-----------------------|-------|-----------------------|------|
| 4010 | HIS® Utility Cart, 2-shelf Unit | 85.4 × 47.3 × 96.0cm | 60kg | GRAY, BLA, PLAT, OWHT | 1 |
| 4011 | HIS® Utility Cart, Open Sided | 85.4 × 47.3 × 96.0cm | 90kg | GRAY, BLA, PLAT, OWHT | 1 |
| 4021 | HIS® Utility Cart, Open Sided | 103.2 × 50.8 × 96.0cm | 135kg | GRAY, BLA, OWHT | 1 |
| 4023 | HIS® Utility Cart with Enclosed End Panels on 3 Sides | 103.2 × 50.8 × 96.0cm | 135kg | BLA, OWHT | 1 |

HI5® FOLDING SERVICE CARTS

PRODUCT FEATURES:

1. Versatile, durable for indoor mobility.
2. Molded shelves, sturdy and durable won't rust, dent, peel.
3. Fully functional and innovative folding mechanism. Carts can be easily folded and opened, saving 50% of the space after folding.
4. Quick locking device to ensure no loosening after opening and folding.
5. Comfortable ergonomic handle for more flexible control.
6. Textured surfaces for non-skid and safe transporting.
7. Spacious countertop for the 4072 cart, which can place two lower railing basins at the same time (8221).
8. 10cm quiet non-marking castors which serve to reduce noise and subsequent floor maintenance; Universal wheel with brake function is more stable when working.



4071



4072

Ergonomic handle for more flexible control

Innovative folding cart save storage space by 50%

Non-slip textured surfaces



Comfortable ergonomic handle for more flexible control



Quick locking device to ensure no loosening after opening and folding



Innovative folding mechanism makes it easier to open and fold



10cm quiet, non-marking castors

| Model | Description | Dimensions | Load | Color | Pack |
|-------|----------------------------|-----------------------|-------|----------------|------|
| 4071 | HI5® Foldable Service Cart | 75.0 × 41.2 × 92.0cm | 160kg | GRAY, BLA, BRN | 1 |
| 4072 | HI5® Foldable Service Cart | 102.5 × 52.3 × 92.0cm | 160kg | GRAY, BLA, BRN | 1 |

HIS® UTILITY SERVICE CARTS



PRODUCT FEATURES:

1. Sturdy and durable, fully functional carts, suitable for handling work in the front and back-of-house.
2. Molded, formed structure of the carts is sturdy and durable - will not rust, dent or come apart.
3. Ergonomic, comfortable handle provides flexible control.
4. Textured surfaces for non-skid and safe transporting.
5. With a spacious countertop, two lower railing basins can be placed at the same time (8211).
6. 10cm quiet non-marking castors which serve to reduce noise and subsequent floor maintenance.
7. The Sundry barrels (4811, 4821) can be placed on both sides to increase the collection capacity.



4081



4082



4083



4084

| Model | Description | Dimensions | Load | Color | Pack |
|-------|--|-----------------------|-------|-------|------|
| 4081 | HIS® Utility Cart | 111.6 × 54.0 × 95.6cm | 135kg | BLA | 1 |
| 4082 | HIS® Utility Cart with Enclosed End Panels on 3 Sides | 111.6 × 54.0 × 95.6cm | 135kg | BLA | 1 |
| 4083 | HIS® Utility Cart with Lockable Doors, Sliding Drawer | 111.6 × 54.0 × 95.6cm | 135kg | BLA | 1 |
| 4084 | HIS® Utility Cart with Lockable Doors, Enclosed Panels | 111.6 × 54.0 × 95.6cm | 135kg | BLA | 1 |

ACCESSORIES



4811



4821



4851

| Model | Description | Dimensions | Capacity | Color | Pack |
|-------|------------------------|----------------------|----------|----------|------|
| 4085 | Enclosed Panels | N/A | N/A | BLA | 1 |
| 4086 | Lockable Doors | N/A | N/A | BLA | 1 |
| 4087 | Trim Panel | 50.6 × 30.8 × 3.7cm | N/A | BLA | 1 |
| 4811 | Utility Bin | 43.2 × 30.8 × 26.7cm | 15L | BLA | 2 |
| 4821 | Utility Bin | 43.2 × 30.8 × 55.9cm | 30L | BLA | 2 |
| 4851 | Utility Sliding Drawer | 65.7 × 46.0 × 8.2cm | N/A | BLA, BRN | 1 |



BITBAR® UTILITY CARTS



PRODUCT FEATURES:

1. Innovative design for easy transportation of a variety of items.
2. Sturdy structural foam construction won't rust, dent, chip, or peel.
3. Molded-in storage compartments and cup holder are available for storing small items and tools.
4. User-friendly, comfortable handles for easy maneuverability.
5. Integrated molded grooves for inserting steel tube or metal reeled coils or other scroll-like items.

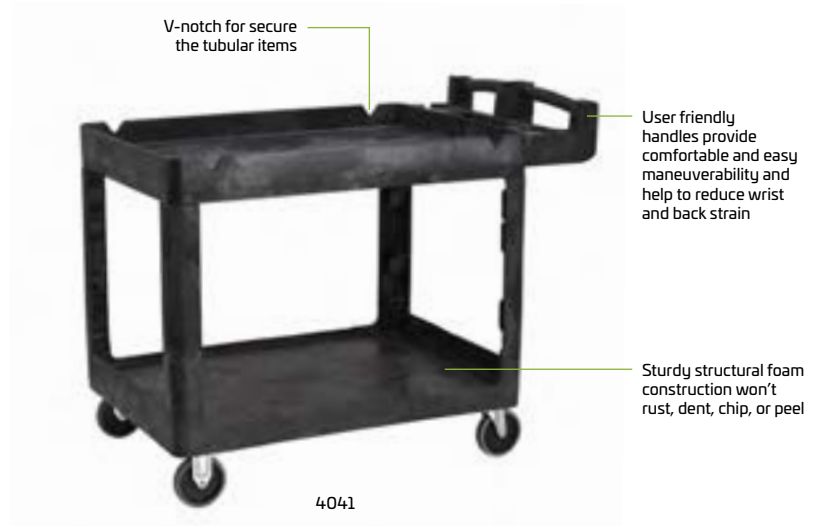

| Model | Description | Dimensions | Load | Color | Caster Type | Pack |
|-------|------------------------------|-----------------------|-------|-----------|-------------|------|
| 4041 | BITBAR® 2-shelf Utility Cart | 115.0 × 64.1 × 98.7cm | 230kg | BLA, BEIG | 12.5cm TPR | 1 |
| 4044 | BITBAR® 2-shelf Utility Cart | 97.8 × 43.5 × 98.7cm | 230kg | BLA, BEIG | 12.5cm TPR | 1 |

BITBAR® FLAT-SHELF CARTS



PRODUCT FEATURES:

1. Innovative design for easily transporting a variety of items.
2. Sturdy structural foam construction won't rust, dent, chip, or peel.
3. Molded-in storage compartments and cup holder are available for storage of small items and tools.
4. User-friendly, comfortable handles for easy maneuverability.
5. Integrated molded grooves for inserting steel tubes or metal reeled coils or other scroll-like items.



| Model | Description | Dimensions | Load | Color | Caster Type | Pack |
|-------|---|----------------------|-------|-----------|-------------|------|
| 4045 | BITBAR® 2-shelf Utility Cart Flat Shelf | 97.8 × 43.5 × 96.8cm | 230kg | BLA, BEIG | 12.5cm TPR | 1 |



UTILITY TROLLEYS



PRODUCT FEATURES:

1. Efficiently transports large bulky loads, and then folds flat for easy storage.
2. Sturdy structural foam deck won't rust, dent, chip, or peel.
3. Non-skid platform surface helps prevent load shifting.
4. Three-position handle lets users push, pull or fold flat for use as a dolly.
5. Non marking casters.



| Model | Description | Dimensions | Load | Color | Pack |
|-------|--|---------------|-------|-------|------|
| 4481 | Utility Trolley, Utility Duty with 7.5cm Casters | 85.0 × 52.1cm | 110kg | BLA | 1 |
| 4482 | Utility Trolley, Standard Duty with 12.5cm Casters | 85.0 × 52.1cm | 230kg | BLA | 1 |

GLASS RACK TROLLEYS



PRODUCT FEATURES:

1. Suitable for carrying cup racks.
2. Reduces work load and promotes efficiency.
3. Plastic reticulation construction won't dent, chip, rust and is sturdy and reliable.
4. Non-marking swivel casters ensure easy maneuverability.
5. Concave design captures water left by glasses.



| Model | Description | Dimensions | Load | Color | Pack |
|-------|--------------------|----------------------|-------|------------|------|
| 4484 | Glass Rack Dolly | 52.5 × 52.5 × 20.0cm | 160kg | GRAY, PLAT | 1 |
| 4485 | Glass Rack Trolley | 64.0 × 52.5 × 94.0cm | 160kg | GRAY, PLAT | 1 |

CATERING DISKS



PRODUCT FEATURES:

1. Adds to strength and durability.
2. Curved handle for easy operation and added strength.
3. Textured surface prevents slippage.
4. Stackable for easy storage.



8241

| Model | Description | Dimensions | Capacity | Color | Pack |
|-------|---------------|---------------|----------|------------|------|
| 8241 | Catering Disk | 40.0 × 30.5cm | N/A | BLA, STRAN | 12 |

GRP NON-SLIP TRAYS



PRODUCT FEATURES:

1. GRP construction ensures strength, durability, resistance to impact and chemical corrosion.
2. Non-slip surface prevents items from falling off.
3. Steel and aluminum reinforced ring adds to strength and rigidity and prevents crushing and deformation.
4. Designed with a stacking boss to allow air circulation, facilitate pallet drying and offer easy placement.
5. Complies with relevant NSF inspection standards.



8251/8252/8253/8254

8255/8256/8257/8258

8267/8268/8269

| Model | Description | Dimensions | Capacity | Color | Pack |
|-------|-------------------------------|---------------|----------|-------|------|
| 8250 | Round GRP Non-slip Tray | Dia 23.0cm | N/A | BRN | 12 |
| 8251 | Round GRP Non-slip Tray | Dia 27.5cm | N/A | BRN | 12 |
| 8252 | Round GRP Non-slip Tray | Dia 35.5cm | N/A | BRN | 12 |
| 8253 | Round GRP Non-slip Tray | Dia 40.6cm | N/A | BRN | 12 |
| 8254 | Round GRP Non-slip Tray | Dia 45.0cm | N/A | BRN | 12 |
| 8255 | Rectangular GRP Non-slip Tray | 35.0 × 25.5cm | N/A | BRN | 12 |
| 8256 | Rectangular GRP Non-slip Tray | 40.5 × 30.5cm | N/A | BRN | 12 |
| 8257 | Rectangular GRP Non-slip Tray | 45.5 × 36.5cm | N/A | BRN | 12 |
| 8258 | Rectangular GRP Non-slip Tray | 51.0 × 38.0cm | N/A | BRN | 12 |
| 8259 | Rectangular GRP Non-slip Tray | 56.0 × 40.5cm | N/A | BRN | 12 |
| 8260 | Rectangular GRP Non-slip Tray | 65.0 × 45.0cm | N/A | BRN | 12 |
| 8267 | Oval GRP Non-slip Tray | 51.0 × 64.0cm | N/A | BRN | 6 |
| 8268 | Oval GRP Non-slip Tray | 56.0 × 69.0cm | N/A | BRN | 6 |
| 8269 | Oval GRP Non-slip Tray | 60.0 × 74.0cm | N/A | BRN | 6 |

PP NON-SLIP TRAYS



PRODUCT FEATURES:

1. PP structure is economical, durable, and chemical resistant.
2. Non-slip surface prevents items from falling off.
3. Designed with a stacking boss to allow air circulation, facilitate pallet drying and offer easy placement.



8281/8282



8287/8288

| Model | Description | Dimensions | Capacity | Color | Pack |
|-------|----------------------------|---------------|----------|-------|------|
| 8281 | Round PP Non-slip Tray | Dia 27.5cm | N/A | BRN | 12 |
| 8282 | Round PP Non-slip Tray | Dia 35.5cm | N/A | BRN | 12 |
| 8283 | Round PP Non-slip Tray | Dia 40.6cm | N/A | BRN | 12 |
| 8284 | Round PP Non-slip Tray | Dia 45.0cm | N/A | BRN | 12 |
| 8285 | Rectangle PP Non-slip Tray | 35.0 × 25.5cm | N/A | BRN | 12 |
| 8286 | Rectangle PP Non-slip Tray | 40.5 × 30.5cm | N/A | BRN | 12 |
| 8287 | Rectangle PP Non-slip Tray | 45.5 × 36.5cm | N/A | BRN | 12 |
| 8288 | Rectangle PP Non-slip Tray | 51.0 × 38.0cm | N/A | BRN | 12 |

WOOD GRAIN NON-SLIP TRAYS



PRODUCT FEATURES:

1. Made of wood fiber, anti-corrosive and durable, not prone to mold, environmentally friendly and degradable.
2. Non-slip surface prevents items from falling off.
3. Dishwasher safe.



8270/8271



8272/8273/8274



8276/8277/8278

| Model | Description | Dimensions | Capacity | Color | Pack |
|-------|------------------------------------|---------------------|----------|----------|------|
| 8270 | Round Wood Grain Non-slip Tray | Dia 39.3cm | N/A | ASH, WAL | 12 |
| 8271 | Round Wood Grain Non-slip Tray | Dia 50.8cm | N/A | ASH, WAL | 12 |
| 8272 | Rectangle Wood Grain Non-slip Tray | 35.5 × 22.8 × 1.6cm | N/A | ASH, WAL | 12 |
| 8273 | Rectangle Wood Grain Non-slip Tray | 43.2 × 29.0 × 1.6cm | N/A | ASH, WAL | 12 |
| 8274 | Rectangle Wood Grain Non-slip Tray | 50.8 × 36.0 × 1.7cm | N/A | ASH, WAL | 12 |
| 8275 | Rectangle Wood Grain Non-slip Tray | 58.4 × 39.0 × 1.8cm | N/A | ASH, WAL | 12 |
| 8276 | Oval Wood Grain Non-slip Tray | 35.5 × 22.8 × 1.6cm | N/A | ASH, WAL | 12 |
| 8277 | Oval Wood Grain Non-slip Tray | 43.2 × 29.0 × 1.6cm | N/A | ASH, WAL | 12 |
| 8278 | Oval Wood Grain Non-slip Tray | 50.8 × 36.0 × 1.7cm | N/A | ASH, WAL | 12 |
| 8279 | Oval Wood Grain Non-slip Tray | 58.4 × 39.0 × 1.8cm | N/A | ASH, WAL | 12 |





SCRAPPER/SPOON-SHAPED SCRAPPERS



PRODUCT FEATURES:

1. A multipurpose tool combining spoon, scoop and scrapper.
2. Body and handle are integrally molded to eliminate the possibility of coming off.
3. Seamless structure eliminates the retention of dirt and bacteria.
4. The convex design on the back of scrapper prevents the contact between the blade and the worktable for reducing the possibility of food contamination.
5. Traditional flat scrapper is for scraping; Spoon-shaped scrapper is used to scoop, dig and wipe.
6. All the handle and body are white.
7. Found in compliance with NSF # 2 inspection standards.
8. Dishwasher safe.



| Model | Description | Dimensions | Capacity | Color | Pack |
|-------|-----------------------|------------|----------|-------|------|
| 8511 | Scrapper | 24.0cm | N/A | WHT | 36 |
| 8512 | Scrapper | 34.0cm | N/A | WHT | 36 |
| 8513 | Scrapper | 42.0cm | N/A | WHT | 36 |
| 8514 | Ice Scraper | 24.0cm | N/A | WHT | 36 |
| 8515 | Spoon-shaped Scrapper | 24.0cm | N/A | WHT | 36 |
| 8516 | Spoon-shaped Scrapper | 34.0cm | N/A | WHT | 36 |
| 8517 | Spoon-shaped Scrapper | 42.0cm | N/A | WHT | 36 |

CHOPPING BOARDS



PRODUCT FEATURES:

1. An ideal tool to ensure safety in working.
2. HDPE molded structure ensures strength and durability.
3. Chopping board color recognition system is the first step to ensure food safety.
4. Red boards are used for raw meat, blue for seafood, brown for cooked meat, green for fruits and vegetables, yellow for poultry and white for dairy.
5. Stainless steel Chopping board holder is safe, clean and durable.
6. A cleaning brush, which is sold separately, can be hung on the Chopping board holder.
7. Found in compliance with NSF standards.



8522/8523



8525/8529



8529



8523

| Model | Description | Dimensions | Thickness | Color | Pack |
|-------|-------------------------------|----------------------|-----------|-------------------------------|------|
| 8520 | Chopping Board | 30.0 × 23.0 × 1.2cm | 1.2cm | BLUE, GRN, RED, YEL, WHT, BRN | 6 |
| 8521 | Chopping Board | 50.8 × 30.8 × 1.5cm | 1.5cm | BLUE, GRN, RED, YEL, WHT, BRN | 6 |
| 8522 | Chopping Board Set (6 Colors) | 50.8 × 30.8 × 1.5cm | 1.5cm | N/A | 1 |
| 8523 | Chopping Board Holder | 30.6 × 28.2 × 28.6cm | N/A | MSILV | 1 |
| 8524 | Chopping Board | 60.6 × 45.5 × 1.5cm | 1.5cm | BLUE, GRN, RED, YEL, WHT, BRN | 6 |
| 8525 | Chopping Board | 50.8 × 30.8 × 2.0cm | 2.0cm | BLUE, GRN, RED, YEL, WHT, BRN | 6 |
| 8526 | Chopping Board | 45.5 × 30.8 × 1.5cm | 1.5cm | BLUE, GRN, RED, YEL, WHT, BRN | 6 |
| 8527 | Chopping Board | 50.8 × 45.5 × 2.0cm | 2.0cm | BLUE, GRN, RED, YEL, WHT, BRN | 6 |
| 8528 | Chopping Board | 60.6 × 60.6 × 2.0cm | 2.0cm | BLUE, GRN, RED, YEL, WHT, BRN | 6 |
| 8529 | Chopping Board Holder | 26.3 × 35.2 × 21.6cm | N/A | BLA | 1 |



CUPCOMB® WAREWASHING SYSTEM



The CUPCOMB® warewashing system has been designed to maximise washing, handling and storage efficiency for restaurants, hotels, hospitals and commercial operations.

The system is engineered for maximum capacity and flexibility with a wide variety of racks and extenders to suit modern catering requirements. With the CUPCOMB system operators will save time, money and resources and help prevent breakage and loss.

As an integrated, fully sealed and mobile storage unit the CUPCOMB system is the optimum warewashing logistics system for catering operations: economical, safe and efficient.

The CUPCOMB® System comprises the CUPCOMB® Cover, CUPCOMB® Racks and CUPCOMB® Dolly to provide an integrated, fully sealed and mobile unit.

PRODUCT FEATURES:

1. Designed for maximum capacity per rack, reducing the number of washing cycles and ultimately saving time and money.
2. Engineered for better washing.
3. Enclosed racks and spacers prevent finger marking and keep dirt away.
4. Color-coded tray racks for easy inventory management.
5. Up to 6 different heights by adding extenders to the base rack.
6. Optional Quick Check Label Clips for easy content identification.
7. With the optional Dolly inventory can be moved easily and safely from one location to another.



CUPFORMS® FULL SIZE GLASS RACKS

PRODUCT FEATURES:

1. Designed for maximum capacity per rack, reducing the number of washing cycles and ultimately saving time and money.
2. Engineered for better washing.
3. Enclosed racks and spacers prevent finger marking and keep dirt away.
4. Color-coded tray racks for easy inventory management.
5. Up to 6 different heights by adding extenders to the base rack.
6. Optional Quick Check Label Clips for easy content identification.
7. With the optional Dolly inventory can be moved easily and safely from one location to another.



9362

CUPFORMS® FULL SIZE GLASS RACKS - 9 COMPARTMENT

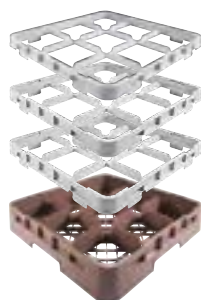

| Model | Description | Max Diameter | Max Height | Dimensions | Color | Pack |
|-------|---------------------------|--------------|------------|----------------------|-------------|------|
| 9090 | Base Rack | 14.8cm | N/A | 50.0 × 50.0 × 10.2cm | LGRAY, RBRN | 6 |
| 9091 | Base Rack with 1 Extender | 14.8cm | 9.0cm | 50.0 × 50.0 × 14.3cm | N/A | 5 |
| 9092 | Base Rack with 2 Extender | 14.8cm | 13.3cm | 50.0 × 50.0 × 18.4cm | N/A | 4 |
| 9093 | Base Rack with 3 Extender | 14.8cm | 17.5cm | 50.0 × 50.0 × 22.5cm | N/A | 3 |
| 9094 | Base Rack with 4 Extender | 14.8cm | 21.6cm | 50.0 × 50.0 × 26.7cm | N/A | 2 |
| 9095 | Base Rack with 5 Extender | 14.8cm | 25.8cm | 50.0 × 50.0 × 30.8cm | N/A | 2 |
| 9096 | Base Rack with 6 Extender | 14.8cm | 30.0cm | 50.0 × 50.0 × 34.9cm | N/A | 2 |

CUPFORMS® FULL SIZE GLASS RACKS - 16 COMPARTMENT

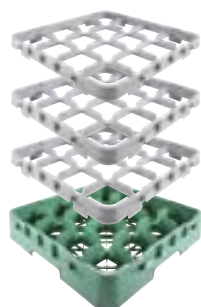

| Model | Description | Max Diameter | Max Height | Dimensions | Color | Pack |
|-------|---------------------------|--------------|------------|----------------------|-------------|------|
| 9160 | Base Rack | 10.9cm | N/A | 50.0 × 50.0 × 10.2cm | LGRAY, SGRN | 6 |
| 9161 | Base Rack with 1 Extender | 10.9cm | 9.0cm | 50.0 × 50.0 × 14.3cm | N/A | 5 |
| 9162 | Base Rack with 2 Extender | 10.9cm | 13.3cm | 50.0 × 50.0 × 18.4cm | N/A | 4 |
| 9163 | Base Rack with 3 Extender | 10.9cm | 17.5cm | 50.0 × 50.0 × 22.5cm | N/A | 3 |
| 9164 | Base Rack with 4 Extender | 10.9cm | 21.6cm | 50.0 × 50.0 × 26.7cm | N/A | 2 |
| 9165 | Base Rack with 5 Extender | 10.9cm | 25.8cm | 50.0 × 50.0 × 30.8cm | N/A | 2 |
| 9166 | Base Rack with 6 Extender | 10.9cm | 30.0cm | 50.0 × 50.0 × 34.9cm | N/A | 2 |

CUPFORMS® FULL SIZE GLASS RACKS - 20 COMPARTMENT

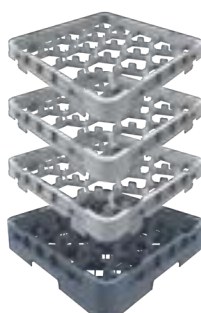

| Model | Description | Max Diameter | Max Height | Dimensions | Color | Pack |
|-------|---------------------------|--------------|------------|----------------------|-------------|------|
| 9200 | Base Rack | 9.8cm | N/A | 50.0 × 50.0 × 10.2cm | LGRAY, GRAY | 6 |
| 9201 | Base Rack with 1 Extender | 9.8cm | 9.0cm | 50.0 × 50.0 × 14.3cm | N/A | 5 |
| 9202 | Base Rack with 2 Extender | 9.8cm | 13.3cm | 50.0 × 50.0 × 18.4cm | N/A | 4 |
| 9203 | Base Rack with 3 Extender | 9.8cm | 17.5cm | 50.0 × 50.0 × 22.5cm | N/A | 3 |
| 9204 | Base Rack with 4 Extender | 9.8cm | 21.6cm | 50.0 × 50.0 × 26.7cm | N/A | 2 |
| 9205 | Base Rack with 5 Extender | 9.8cm | 25.8cm | 50.0 × 50.0 × 30.8cm | N/A | 2 |
| 9206 | Base Rack with 6 Extender | 9.8cm | 30.0cm | 50.0 × 50.0 × 34.9cm | N/A | 2 |

CUPCOMB® FULL SIZE GLASS RACKS - 25 COMPARTMENT

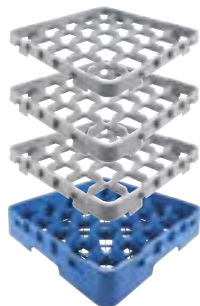

| Model | Description | Max Diameter | Max Height | Dimensions | Color | Pack |
|-------|---------------------------|--------------|------------|----------------------|------------|------|
| 9250 | Base Rack | 8.7cm | N/A | 50.0 × 50.0 × 10.2cm | LGRAY, IND | 6 |
| 9251 | Base Rack with 1 Extender | 8.7cm | 9.0cm | 50.0 × 50.0 × 14.3cm | N/A | 5 |
| 9252 | Base Rack with 2 Extender | 8.7cm | 13.3cm | 50.0 × 50.0 × 18.4cm | N/A | 4 |
| 9253 | Base Rack with 3 Extender | 8.7cm | 17.5cm | 50.0 × 50.0 × 22.5cm | N/A | 3 |
| 9254 | Base Rack with 4 Extender | 8.7cm | 21.6cm | 50.0 × 50.0 × 26.7cm | N/A | 2 |
| 9255 | Base Rack with 5 Extender | 8.7cm | 25.8cm | 50.0 × 50.0 × 30.8cm | N/A | 2 |
| 9256 | Base Rack with 6 Extender | 8.7cm | 30.0cm | 50.0 × 50.0 × 34.9cm | N/A | 2 |

CUPCOMB® FULL SIZE GLASS RACKS - 30 COMPARTMENT

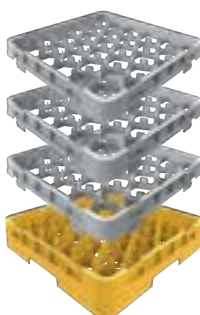

| Model | Description | Max Diameter | Max Height | Dimensions | Color | Pack |
|-------|---------------------------|--------------|------------|----------------------|------------|------|
| 9300 | Base Rack | 7.9cm | N/A | 50.0 × 50.0 × 10.2cm | LGRAY, YEL | 6 |
| 9301 | Base Rack with 1 Extender | 7.9cm | 9.0cm | 50.0 × 50.0 × 14.3cm | N/A | 5 |
| 9302 | Base Rack with 2 Extender | 7.9cm | 13.3cm | 50.0 × 50.0 × 18.4cm | N/A | 4 |
| 9303 | Base Rack with 3 Extender | 7.9cm | 17.5cm | 50.0 × 50.0 × 22.5cm | N/A | 3 |
| 9304 | Base Rack with 4 Extender | 7.9cm | 21.6cm | 50.0 × 50.0 × 26.7cm | N/A | 2 |
| 9305 | Base Rack with 5 Extender | 7.9cm | 25.8cm | 50.0 × 50.0 × 30.8cm | N/A | 2 |
| 9306 | Base Rack with 6 Extender | 7.9cm | 30.0cm | 50.0 × 50.0 × 34.9cm | N/A | 2 |

CUPCOMB® FULL SIZE GLASS RACKS - 36 COMPARTMENT

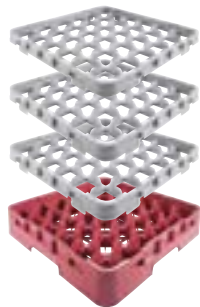

| Model | Description | Max Diameter | Max Height | Dimensions | Color | Pack |
|-------|---------------------------|--------------|------------|----------------------|-------------|------|
| 9360 | Base Rack | 7.2cm | N/A | 50.0 × 50.0 × 10.2cm | LGRAY, LRED | 6 |
| 9361 | Base Rack with 1 Extender | 7.2cm | 9.0cm | 50.0 × 50.0 × 14.3cm | N/A | 5 |
| 9362 | Base Rack with 2 Extender | 7.2cm | 13.3cm | 50.0 × 50.0 × 18.4cm | N/A | 4 |
| 9363 | Base Rack with 3 Extender | 7.2cm | 17.5cm | 50.0 × 50.0 × 22.5cm | N/A | 3 |
| 9364 | Base Rack with 4 Extender | 7.2cm | 21.6cm | 50.0 × 50.0 × 26.7cm | N/A | 2 |
| 9365 | Base Rack with 5 Extender | 7.2cm | 25.8cm | 50.0 × 50.0 × 30.8cm | N/A | 2 |
| 9366 | Base Rack with 6 Extender | 7.2cm | 30.0cm | 50.0 × 50.0 × 34.9cm | N/A | 2 |

CUPCOMB® FULL SIZE GLASS RACKS - 49 COMPARTMENT

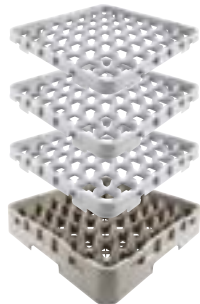

| Model | Description | Max Diameter | Max Height | Dimensions | Color | Pack |
|-------|---------------------------|--------------|------------|----------------------|--------------|------|
| 9490 | Base Rack | 6.0cm | N/A | 50.0 × 50.0 × 10.2cm | LGRAY, LBEIG | 6 |
| 9491 | Base Rack with 1 Extender | 6.0cm | 9.0cm | 50.0 × 50.0 × 14.3cm | N/A | 5 |
| 9492 | Base Rack with 2 Extender | 6.0cm | 13.3cm | 50.0 × 50.0 × 18.4cm | N/A | 4 |
| 9493 | Base Rack with 3 Extender | 6.0cm | 17.5cm | 50.0 × 50.0 × 22.5cm | N/A | 3 |
| 9494 | Base Rack with 4 Extender | 6.0cm | 21.6cm | 50.0 × 50.0 × 26.7cm | N/A | 2 |
| 9495 | Base Rack with 5 Extender | 6.0cm | 25.8cm | 50.0 × 50.0 × 30.8cm | N/A | 2 |
| 9496 | Base Rack with 6 Extender | 6.0cm | 30.0cm | 50.0 × 50.0 × 34.9cm | N/A | 2 |

CUPFORMS® HALF SIZE GLASS RACKS

PRODUCT FEATURES:

1. Designed for maximum capacity per rack, reducing the number of washing cycles and ultimately saving time and money.
2. Engineered for better washing.
3. Enclosed racks and spacers prevent finger marking and keep dirt away.
4. Color-coded tray racks for easy inventory management.
5. Up to 6 different heights by adding extenders to the base rack.
6. Half-sized racks are useful for carrying lighter loads than full-sized racks and for handy storage of drinkware where space is at a premium.
7. Ideal for use with smaller under-bench dishwashers.
8. Optional Quick Check Label Clips for easy content identification.



9101

CUPFORMS® HALF SIZE GLASS RACKS - 8 COMPARTMENT

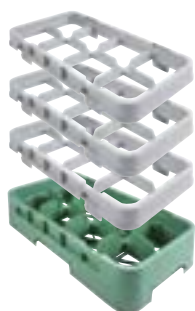

| Model | Description | Max Diameter | Max Height | Dimensions | Color | Pack |
|-------|---------------------------|--------------|------------|----------------------|-------------|------|
| 9080 | Base Rack | 10.3cm | N/A | 50.0 × 25.0 × 10.2cm | LGRAY, SGRN | 6 |
| 9081 | Base Rack with 1 Extender | 10.3cm | 9.0cm | 50.0 × 25.0 × 14.3cm | N/A | 5 |
| 9082 | Base Rack with 2 Extender | 10.3cm | 13.3cm | 50.0 × 25.0 × 18.4cm | N/A | 4 |
| 9083 | Base Rack with 3 Extender | 10.3cm | 17.5cm | 50.0 × 25.0 × 22.5cm | N/A | 3 |
| 9084 | Base Rack with 4 Extender | 10.3cm | 21.6cm | 50.0 × 25.0 × 26.7cm | N/A | 2 |
| 9085 | Base Rack with 5 Extender | 10.3cm | 25.8cm | 50.0 × 25.0 × 30.8cm | N/A | 2 |
| 9086 | Base Rack with 6 Extender | 10.3cm | 30.0cm | 50.0 × 25.0 × 34.9cm | N/A | 2 |

CUPFORMS® HALF SIZE GLASS RACKS - 10 COMPARTMENT



| Model | Description | Max Diameter | Max Height | Dimensions | Color | Pack |
|-------|---------------------------|--------------|------------|----------------------|------------|------|
| 9100 | Base Rack | 8.8cm | N/A | 50.0 × 25.0 × 10.2cm | LGRAY, IND | 6 |
| 9101 | Base Rack with 1 Extender | 8.8cm | 9.0cm | 50.0 × 25.0 × 14.3cm | N/A | 5 |
| 9102 | Base Rack with 2 Extender | 8.8cm | 13.3cm | 50.0 × 25.0 × 18.4cm | N/A | 4 |
| 9103 | Base Rack with 3 Extender | 8.8cm | 17.5cm | 50.0 × 25.0 × 22.5cm | N/A | 3 |
| 9104 | Base Rack with 4 Extender | 8.8cm | 21.6cm | 50.0 × 25.0 × 26.7cm | N/A | 2 |
| 9105 | Base Rack with 5 Extender | 8.8cm | 25.8cm | 50.0 × 25.0 × 30.8cm | N/A | 2 |
| 9106 | Base Rack with 6 Extender | 8.8cm | 30.0cm | 50.0 × 25.0 × 34.9cm | N/A | 2 |

CUPFORMS® HALF SIZE GLASS RACKS - 17 COMPARTMENT



| Model | Description | Max Diameter | Max Height | Dimensions | Color | Pack |
|-------|---------------------------|--------------|------------|----------------------|-------------|------|
| 9170 | Base Rack | 7.3cm | N/A | 50.0 × 25.0 × 10.2cm | LGRAY, LRED | 6 |
| 9171 | Base Rack with 1 Extender | 7.3cm | 9.0cm | 50.0 × 25.0 × 14.3cm | N/A | 5 |
| 9172 | Base Rack with 2 Extender | 7.3cm | 13.3cm | 50.0 × 25.0 × 18.4cm | N/A | 4 |
| 9173 | Base Rack with 3 Extender | 7.3cm | 17.5cm | 50.0 × 25.0 × 22.5cm | N/A | 3 |
| 9174 | Base Rack with 4 Extender | 7.3cm | 21.6cm | 50.0 × 25.0 × 26.7cm | N/A | 2 |
| 9175 | Base Rack with 5 Extender | 7.3cm | 25.8cm | 50.0 × 25.0 × 30.8cm | N/A | 2 |
| 9176 | Base Rack with 6 Extender | 7.3cm | 30.0cm | 50.0 × 25.0 × 34.9cm | N/A | 2 |

CUPCOMB® BASE / FLATWARE RACKS



PRODUCT FEATURES:

1. Base Racks are designed for larger objects such as pots, frying pans, lids and larger food preparation and utility items.
2. Flatware racks are ideal for washing, soaking and storing flatware.
3. Available in full size or half size.
4. Use half-sized flatware racks for carrying lighter loads and for effective use of space.
5. Configure to 4 different heights by adding extenders to the base rack.



9610



9601

CUPCOMB® BASE RACK – FULL SIZE

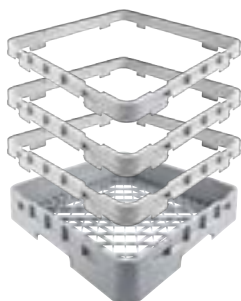

| Model | Description | Inside Rack Height | Outside Rack Height | Dimensions | Color | Pack |
|-------|---------------------------|--------------------|---------------------|----------------------|-------|------|
| 9600 | Base Rack | 8.3cm | 10.1cm | 50.0 × 50.0 × 10.1cm | LGRAY | 6 |
| 9601 | Base Rack with 1 Extender | 12.4cm | 14.3cm | 50.0 × 50.0 × 14.3cm | LGRAY | 5 |
| 9602 | Base Rack with 2 Extender | 16.5cm | 18.4cm | 50.0 × 50.0 × 18.4cm | LGRAY | 4 |
| 9603 | Base Rack with 3 Extender | 20.6cm | 22.5cm | 50.0 × 50.0 × 22.5cm | LGRAY | 3 |

CUPCOMB® BASE RACK – HALF SIZE



| Model | Description | Inside Rack Height | Outside Rack Height | Dimensions | Color | Pack |
|-------|---------------------------|--------------------|---------------------|----------------------|-------|------|
| 9610 | Base Rack | 8.3cm | 10.1cm | 50.0 × 25.0 × 10.1cm | LGRAY | 6 |
| 9611 | Base Rack with 1 Extender | 12.4cm | 14.3cm | 50.0 × 25.0 × 14.3cm | LGRAY | 5 |
| 9612 | Base Rack with 2 Extender | 16.5cm | 18.4cm | 50.0 × 25.0 × 18.4cm | LGRAY | 4 |
| 9613 | Base Rack with 3 Extender | 20.6cm | 22.5cm | 50.0 × 25.0 × 22.5cm | LGRAY | 3 |

CUPCOMB® FLATWARE RACK – FULL AND HALF SIZE



| Model | Description | Inside Rack Height | Outside Rack Height | Dimensions | Color | Pack |
|-------|---------------------------|--------------------|---------------------|----------------------|-------|------|
| 9650 | Flatware Rack – Full Size | 6.7cm | 10.1cm | 50.0 × 50.0 × 10.1cm | LGRAY | 6 |
| 9651 | Flatware Rack – Half Size | 6.7cm | 10.1cm | 50.0 × 25.0 × 10.1cm | LGRAY | 6 |



GUPPEOM® PEG RACK



PRODUCT FEATURES:

1. Peg racks come in a 9 × 9 or a 5 × 9 row configuration.
2. They are designed to accommodate different sized plates, bowls, platters and other items.
3. 9 × 9 Peg Rack is suitable for storing:
 - 18 plates at 25.4cm
 - 12 plates at 30.5cm
 - 27 plates at 19cm or
 - 9 trays at 36 × 46cm
4. 5 × 9 Peg Rack is suitable for storing:
 - standard dinner plates in one direction and soup plates, bowls and lids in the other direction.
 - 10 bowls, plates or lids at 25.4cm.
5. Color-coded tray racks for easy inventory management.
6. Optional Quick Check Label Clips for easy content identification.



9631

GUPPEOM® PEG RACK - 5 × 9

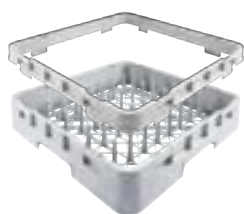

| Model | Description | Inside Rack Height | Outside Rack Height | Dimensions | Color | Pack |
|-------|---------------------------|--------------------|---------------------|----------------------|-------|------|
| 9620 | 5 × 9 Peg Rack | 6.7cm | 10.1cm | 50.0 × 50.0 × 10.1cm | LGRAY | 6 |
| 9621 | Base Rack with 1 Extender | 10.8cm | 14.3cm | 50.0 × 50.0 × 14.3cm | LGRAY | 5 |

GUPPEOM® PEG RACK - 9 × 9

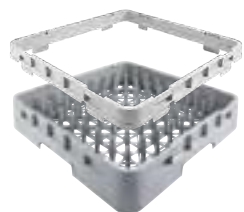

| Model | Description | Inside Rack Height | Outside Rack Height | Dimensions | Color | Pack |
|-------|---------------------------|--------------------|---------------------|----------------------|-------|------|
| 9630 | 9 × 9 Peg Rack | 6.7cm | 10.1cm | 50.0 × 50.0 × 10.1cm | LGRAY | 6 |
| 9631 | Base Rack with 1 Extender | 10.8cm | 14.3cm | 50.0 × 50.0 × 14.3cm | LGRAY | 5 |

GUPPEOM® TRAY RACK



PRODUCT FEATURES:

1. Open-ended tray racks hold up to 9 serving trays or full-size baking trays with ease.
2. The open-ended design aids placement and removal of trays of various lengths. Color-coded tray racks for easy inventory management.
3. Optional Quick Check Label Clips for easy content identification.



9640

GUPPEOM® TRAY RACK

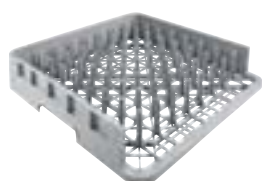

| Model | Description | Inside Rack Height | Outside Rack Height | Dimensions | Color | Pack |
|-------|--------------------|--------------------|---------------------|----------------------|-------|------|
| 9640 | Open End Tray Rack | 6.7cm | 10.1cm | 50.0 × 50.0 × 10.1cm | LGRAY | 6 |

GUPGOMB® FLATWARE BASKET



PRODUCT FEATURES:

1. Easily load and wash utensils and flatware.



| Model | Description | Dimensions | Capacity | Color | Pack |
|-------|---|----------------------|----------|-------|------|
| 9002 | 8 Compartment Half Size Flatware Basket | 46.0 × 21.0 × 18.0cm | N/A | LGRAY | 6 |
| 9003 | 8 Compartment Half Size Flatware Basket with Handle | 46.0 × 21.0 × 18.0cm | N/A | LGRAY | 6 |

GUPGOMB® EXTENDER



PRODUCT FEATURES:

1. Up to 6 different heights by adding extenders to the base rack.



| Model | Description | Max Diameter | Max Height | Dimensions | Color | Pack |
|-------|-----------------------------------|--------------|------------|---------------------|-------|------|
| 9099 | 9 Compartment Full Size Extender | 14.8cm | N/A | 49.7 × 49.7 × 7.8cm | LGRAY | 12 |
| 9169 | 16 Compartment Full Size Extender | 10.9cm | N/A | 49.7 × 49.7 × 7.8cm | LGRAY | 12 |
| 9209 | 20 Compartment Full Size Extender | 9.8cm | N/A | 49.7 × 49.7 × 7.8cm | LGRAY | 12 |
| 9259 | 25 Compartment Full Size Extender | 8.7cm | N/A | 49.7 × 49.7 × 7.8cm | LGRAY | 12 |
| 9309 | 30 Compartment Full Size Extender | 7.9cm | N/A | 49.7 × 49.7 × 7.8cm | LGRAY | 12 |
| 9369 | 36 Compartment Full Size Extender | 7.2cm | N/A | 49.7 × 49.7 × 7.8cm | LGRAY | 12 |
| 9499 | 49 Compartment Full Size Extender | 6.0cm | N/A | 49.7 × 49.7 × 7.8cm | LGRAY | 12 |
| 9089 | 8 Compartment Half Size Extender | 10.3cm | N/A | 50.0 × 25.0 × 7.8cm | LGRAY | 12 |
| 9109 | 10 Compartment Half Size Extender | 8.8cm | N/A | 50.0 × 25.0 × 7.8cm | LGRAY | 12 |
| 9179 | 17 Compartment Half Size Extender | 7.3cm | N/A | 50.0 × 25.0 × 7.8cm | LGRAY | 12 |
| 9009 | Full Size Open Extender | N/A | N/A | 50.0 × 50.0 × 7.8cm | LGRAY | 12 |
| 9000 | Half Size Open Extender | N/A | N/A | 50.0 × 25.0 × 7.8cm | LGRAY | 12 |

ACCESSORIES



- The CUPCOMB® Cover fits neatly and securely over any CUPCOMB® Rack.
- Effectively seals the contents beneath preventing food and other contaminants from falling through. It also helps provides secure protection of the contents to reduce breakage. Use it with a CUPCOMB® Dolly for handy, portable and sanitary storage.
- Ideal for transporting stacked dish racks for high efficiency.
- Equipped with non-marking, heavy-duty casters that help to easily maneuver across various surface types.
- Heavy duty plastic construction ensures a long service life.
- Sturdy edges and angled side walls ensure excess water is collected in the Dolly base and not spread across floors when moving.
- Quick Check Label Clips aid efficiency by helping the user to choose the correct rack without the need to inspect the contents.
- 34 different types of pre-printed label clips are available (refer below).
- Label Clips can also be branded with a company logo.

QUICK CHECK LABEL CLIPS

| | | | | | | |
|----------------------------|-------------------------------|--------------------------------|-------------------------------|--------------------------------|---------------------------|---------------------------|
| Beer 9901 | Beer Mug 9902 | Brandy 9903 | Champagne 9904 | Champagne Mug 9905 | Coffee Mug 9906 | Collins 9907 |
| Cordial 9908 | Creamer 9909 | Cup 9910 | Decanter 9911 | Flatware 9912 | Goblet 9913 | Grande 9914 |
| Hi-Ball 9915 | Hurricane 9916 | Iced Tea 9917 | Irish Coffee 9918 | Juice 9919 | Margarita 9920 | Martini 9921 |
| Old Fashion 9922 | Pilsner 9923 | Red Wine 9924 | Rocks (Footed) 9925 | Rocks (Tumbler) 9926 | Sherry 9927 | Shot Glass 9928 |
| Sorbet 9929 | Water (Footed) 9930 | Water (Tumbler) 9931 | White Wine 9932 | Wine 9933 | Port 9934 | |

| Model | Description | Dimensions | Capacity | Color | Pack |
|-----------|-------------------|---------------------|----------|---------------|------|
| 4484 | Dolly | 52.5 × 52.5 × 20cm | N/A | GRAY, PLAT | 1 |
| 4485 | Dolly with Handle | 64.0 × 52.5 × 94cm | N/A | GRAY, PLAT | 1 |
| 9001 | Half Size Cover | 50.0 × 25.0 × 3.2cm | N/A | WHT | 1 |
| 9008 | Full Size Cover | 50.0 × 50.0 × 3.2cm | N/A | GRN, RED, WHT | 1 |
| See Above | Label Clip | 6.0 × 4.5 × 0.6cm | N/A | WHT | 12 |



HOW TO PICK THE RIGHT CUPCOMP® RACK

There is a size guide provided on page 327 of this brochure. Using the guide, you can choose the right CUPCOMP® rack which best suited to your drinkware.



DIAMETER

Place the glass upside down over the circular chart. Look down over the glass. Use whichever circle is of the largest diameter - either the glass base, body or rim to determine which compartment rack size the glass fits within.



HEIGHT

Use the vertical guide to determine the number of extenders that should be used. If the height of the glass is between two extenders, select the higher extender.



TOTE BOXES



TOTE BOXES



PRODUCT FEATURES:

1. Reinforced handles, bottom and ribs for added strength and durability.
2. Rounded corners for easy cleaning.
3. Commercial dishwasher safe.



8211



8212



8216



8222



8221



8226

| Model | Description | Dimensions | Capacity | Color | Pack |
|-------|-------------------------|----------------------|----------|----------------|------|
| 8211 | Bus/Utility Box | 50.0 × 37.5 × 12.7cm | 17L | GRAY, WHT, BRN | 12 |
| 8212 | Bus/Utility Box | 50.8 × 38.1 × 17.8cm | 23L | GRAY, WHT | 12 |
| 8216 | Lid for 8211/8212 | 51.1 × 38.7 × 1.5cm | N/A | GRAY, WHT | 12 |
| 8220 | Bus/Utility Box | 54.6 × 43.5 × 12.7cm | 20L | GRAY, BRN | 6 |
| 8221 | Bus/Utility Box | 54.6 × 43.5 × 17.8cm | 29L | GRAY, BRN | 6 |
| 8222 | Divided Bus/Utility Box | 54.6 × 43.5 × 18.2cm | 26L | GRAY, BRN | 6 |
| 8226 | Lid for 8220/8221/8222 | 54.8 × 44.1 × 1.7cm | N/A | GRAY, BRN | 6 |

CUTLERY BINS



PRODUCT FEATURES:

1. Made of durable commercial grade plastics plus special resin.
2. Ribbed design for added strength and durability.
3. Ideal for storage of dishware or condiment packets.



8231

| Model | Description | Dimensions | Capacity | Color | Pack |
|-------|-----------------------------|---------------------|----------|-------|------|
| 8231 | Cutlery Bin, 4 Compartments | 54.0 × 29.2 × 9.5cm | N/A | GRAY | 12 |

CONDIMENT DISPENSERS



PRODUCT FEATURES:

1. Convenient and healthy storage of spices and food ingredients.
2. Resistant to scratching due to the textured surface of the transparent cover.
3. The protruding transparent cover edge is easy to open.
4. Smooth surface, easy to clean.



8441



8443

| Model | Description | Dimensions | Capacity | Color | Pack |
|-------|---|---------------------|----------|-------|------|
| 8441 | Condiment Dispenser with Three 0.9L Inserts | 49.8 × 15.9 × 9.5cm | N/A | BLA | 1 |
| 8442 | Condiment Dispenser with Four 0.7L Inserts | 49.8 × 15.9 × 9.5cm | N/A | BLA | 1 |
| 8443 | Condiment Dispenser with Six 0.5L Inserts | 49.8 × 15.9 × 9.5cm | N/A | BLA | 1 |

PITCHERS



PRODUCT FEATURES:

1. Plastic construction is easy to handle.
2. Lighter than a glass jug, economical and practical.
3. Ergonomic handle, comfortable and easy to use.
4. Complies with NSF #2 inspection standards.

Note: 8341, 8342, 8343 and 8344 are not BPA free.



8262



8263



8264

| Model | Description | Dimensions | Capacity | Color | Pack |
|-------|------------------------|---------------|----------|-------|------|
| 8261 | Pitcher | 11.0 × 17.5cm | 0.9L | CLR | 6 |
| 8262 | Pitcher | 12.5 × 20.0cm | 1.4L | CLR | 6 |
| 8263 | Pitcher | 13.0 × 20.0cm | 1.8L | CLR | 6 |
| 8264 | Pitcher | 13.6 × 22.0cm | 2.1L | CLR | 6 |
| 8341 | Pitcher (Not BPA Free) | 11.0 × 17.5cm | 0.9L | CLR | 6 |
| 8342 | Pitcher (Not BPA Free) | 12.5 × 20.0cm | 1.4L | CLR | 6 |
| 8343 | Pitcher (Not BPA Free) | 13.0 × 20.0cm | 1.8L | CLR | 6 |
| 8344 | Pitcher (Not BPA Free) | 13.6 × 22.0cm | 2.1L | CLR | 6 |

BUDGET POTS



PRODUCT FEATURES:

1. For drinks such as juice, iced tea and water when dining.
2. Tight fitting lid with three positions - closed, full or half-opened..
3. Wide opening for easy cleaning.
4. Ergonomic handle, comfortable and easy to use.
5. Dishwasher safe.



8265



8266

| Model | Description | Dimensions | Capacity | Color | Pack |
|-------|-------------------|------------|----------|-------|------|
| 8265 | Cold Water Bottle | N/A | 2.0L | CLR | 6 |
| 8266 | Cold Water Bottle | N/A | 3.8L | CLR | 6 |



KID&COOL® MICROBAN® YOUTH SEATS



PRODUCT FEATURES:

1. Designed with safety and cleanliness in mind for your youngest patrons.
2. Complies with ASTM F404-18 and TUV standards.
3. Modern appearance plus ant-microbial technologies allow easier cleaning than wooden seats.
4. Microban® anti-microbial technologies provide full protection and resist odor and stain due to bacteria.
5. Stackable for easy storage.



8011

MICROBAN®

MICROBAN® ANTI-MICROBIAL PROTECTION TECHNOLOGIES

1. Microban® anti-microbial technologies provide full protection by working to destroy or inhibit the growth and reproduction of bacteria, mold and mildew.
2. Microban® anti-microbial ingredients have been added to the baby changing station during its production for permanent protection.



Plastic sample without Microban® anti-microbial ingredients.



Plastic sample with Microban® anti-microbial ingredients.



8013

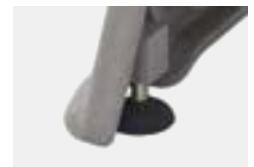

Optional Non-slip Feet Pad Set (8016) can increase the stability of the child seat

*Microban® is the registered owner of Microban® trademark, and reserves all the rights. Microban® anti-microbial protection is not designed to protect users against disease causing micro-organisms and is not a substitute for routine cleaning.

| Model | Description | Dimensions | Color | Pack |
|-------|--|----------------------|--------------------------------|------|
| 8011 | Kid&Cool® Microban® Youth Seat without Wheels | 63.6 × 58.3 × 76.8cm | GRN, BRN, BLA, PLAT | 1 |
| 8012 | Kid&Cool® Microban® Youth Seat with Wheels | 63.6 × 58.3 × 77.3cm | GRN, BRN, BLA, PLAT | 1 |
| 8013 | Tray for 8011/8012/8014 | 42.4 × 30.0 × 5.5cm | BLUE, GRN, RED, BLA, BRN, PLAT | 1 |
| 8014 | Kid&Cool® Microban® Youth Seat RTA (Ready to Assemble) no Wheels | 63.6 × 58.3 × 76.8cm | BLUE, GRN, BLA, BRN, PLAT | 1 |
| 8015 | Caster Kit | N/A | N/A | 1 |
| 8016 | Non-slip Feet Pad Set | N/A | BLA | 1 |



HEIMDALL® BABY CHANGING STATIONS



PRODUCT FEATURES:

1. Wide table is equipped with adjustable seat belts enhancing safety and reliability.
2. All plastic web structure ensures strength and durability.
3. Die cast molding is convenient for hanging accessories.
4. Storage units at the top of the table are convenient to place baby care products.
5. Closed width is only 10.2cm, saving space.
6. Table is equipped with handle, convenient to open.
7. Built-in shelf and liner storage.
8. Antibacterial technology can inhibit bacteria growth and odor effectively.
9. Meeting the standards of ASTM F2285 and EN 12221-1.



8021



8023



8023

MICROBAN®

MICROBAN® ANTI-MICROBIAL PROTECTION TECHNOLOGIES

1. Microban® anti-microbial technologies provide full protection by working to destroy or inhibit the growth and reproduction of bacteria, mold and mildew.
2. Microban® anti-microbial ingredients have been added to the baby changing station during its production for permanent protection.



Plastic sample without Microban® anti-microbial ingredients.



Plastic sample with Microban® anti-microbial ingredients.

*Microban® is the registered owner of Microban® trademark, and reserves all the rights. Microban® anti-microbial protection is not designed to protect users against disease causing micro-organisms and is not a substitute for routine cleaning.



Die cast molding is convenient for hanging accessories.
Storage units at the top of the table are convenient for placing baby care products

| Model | Description | Dimensions | Color | Pack |
|-------|--|------------------------------|-------|------|
| 8021 | HEIMDALL® Baby Changing Station | Closed: 84.5 × 54.6 × 10.2cm | LPLAT | 1 |
| 8022 | Protective Liners For Baby Changing Station (20 Units) | 32.5 × 44.5cm | WHT | 16 |
| 8023 | HEIMDALL® Baby Changing Station | Closed: 58.4 × 86.6 × 10.2cm | LPLAT | 1 |

KID&COOL® MICROBAN® INFANT SAFETY SEATS



PRODUCT FEATURES:

1. All plastic web structure ensures strength and durability.
2. Strap type safety belt for effective protection.
3. Closed width is only 13.0cm, saving space.
4. Smooth surface for easy cleaning.
5. Antibacterial technology can inhibit bacteria growth and odor effectively.
6. Meeting the standards of ASTM F2613 and EN 12520.



8031

| Model | Description | Dimensions | Color | Pack |
|-------|--|------------------------------|-------|------|
| 8031 | KID&COOL® Microban® Infant Safety Seat | Closed: 35.5 × 13.0 × 48.6cm | LPLAT | 1 |





FLOOR SWEEPS



PRODUCT FEATURES:

1. Designed to clean a variety of surfaces.
2. Plastic body, non-absorbent, and easy to keep clean.
3. PET bristles are strong, durable, and resist grease or water stains.
4. Materials meet FDA requirements.
5. Two handle holes on either side of the block for even wear.



| Model | Description | Dimensions | Capacity | Color | Pack |
|-------|------------------------------|------------|----------|--------------------------|------|
| 6695 | 45.0cm Floor Sweep, PET Fill | 45.0cm | N/A | BLUE, GRN, RED, YEL, WHT | 12 |
| 6696 | 61.0cm Floor Sweep, PET Fill | 61.0cm | N/A | BLUE, GRN, RED, YEL, WHT | 12 |

COUNTER BRUSHES



PRODUCT FEATURES:

1. Comfortable handle for quick and easy cleaning.
2. PET bristles are strong, durable, and resist grease or water stains.
3. Materials meet FDA requirements.
4. Handle with hang-up hole for easy storage.



| Model | Description | Dimensions | Capacity | Color | Pack |
|-------|-------------------------|------------|----------|--------------------------|------|
| 6705 | Counter Brush, PET Fill | 28.5cm | N/A | BLUE, GRN, RED, YEL, WHT | 12 |
| 6706 | Counter Brush, PET Fill | 38.5cm | N/A | BLUE, GRN, RED, YEL, WHT | 12 |

MULTI-PURPOSE BRUSHES



PRODUCT FEATURES:

1. Versatile, suitable for any catering industry.
2. PET bristles are strong, durable, and resist grease or water stains.
3. Materials meet FDA requirements.
4. Handle with hang-up hole for easy storage.



| Model | Description | Dimensions | Capacity | Color | Pack |
|-------|---|------------|----------|--------------------------|------|
| 6714 | Short Handle Multi-purpose Cleaning Brush, PET Fill | 24.0cm | N/A | BLUE, GRN, RED, YEL, WHT | 12 |
| 6724 | Long Handle Multi-purpose Cleaning Brush, PET Fill | 52.0cm | N/A | BLUE, GRN, RED, YEL, WHT | 12 |

CLEANING BRUSHES



PRODUCT FEATURES:

1. Versatile, suitable for any catering industries.
2. Durable PP bristles resist wearing or breaking.
3. Ideal for cleaning crevices and corners.
4. Comfortable plastic handles resist splitting or breaking.



| Model | Description | Dimensions | Capacity | Color | Pack |
|-------|-------------------------|------------|----------|--------------------------|------|
| 6757 | Cleaning Brush, PP Fill | 12.7cm | N/A | BLUE, GRN, RED, YEL, WHT | 12 |
| 6758 | Cleaning Brush, PP Fill | 15.7cm | N/A | BLUE, GRN, RED, YEL, WHT | 12 |
| 6759 | Cleaning Brush, PP Fill | 15.7cm | N/A | BLUE, GRN, RED, YEL, WHT | 12 |
| 6760 | Cleaning Brush, PP Fill | 21.0cm | N/A | BLUE, GRN, RED, YEL, WHT | 12 |

CHOPPING BOARD CLEANING BRUSHES



PRODUCT FEATURES:

1. User friendly handles.
2. Durable PP bristles resist wearing or breaking.
3. Materials meet FDA requirements.
4. Dishwasher safe.



| Model | Description | Dimensions | Capacity | Color | Pack |
|-------|--|--------------|----------|-------------------------------|------|
| 6725 | Chopping Board Cleaning Brush, PP Fill | 15.0 x 6.4cm | N/A | BLUE, GRN, RED, YEL, WHT, BRN | 12 |
| 6726 | Chopping Board Cleaning Brush, PP Fill | 15.0 x 6.4cm | N/A | BLUE, GRN, RED, YEL, WHT, BRN | 12 |

ANGLE BROOMS



PRODUCT FEATURES:

1. Block with two handle holes (one straight hole and one angle hole) for two different cleaning purposes.
2. The straight hole for general purpose cleaning. The angle hole is suitable for cleaning of corners and wall-edges.
3. PET bristles are strong, durable, and resist grease or water stains.



6623

| Model | Description | Dimensions | Capacity | Color | Pack |
|-------|--------------|------------|----------|--------------------------|------|
| 6623 | Angle Brooms | 32.0cm | N/A | BLUE, GRN, RED, YEL, WHT | 12 |

VEGETABLE CLEANING BRUSHES



PRODUCT FEATURES:

1. 6611 suitable for cleaning of white and red potatoes.
2. 5691 has a round enclosed structure, suitable for washing vegetables from all directions.
3. 5692 has an oval enclosed structure suitable for a variety of cleaning in the kitchen.
4. Comfortable plastic handle is easy to use.
5. Materials meet FDA requirements.
6. Handle with hang-up hole for easy storage.



6611



5691

| Model | Description | Dimensions | Capacity | Color | Pack |
|-------|----------------------------------|--------------------|----------|-------|------|
| 6611 | Potato Cleaning Brush | 12.0 × 5.1 × 4.0cm | N/A | WHT | 12 |
| 5691 | Round Vegetable Cleaning Brush | 24.5cm | N/A | WHT | 12 |
| 5692 | Oval Multipurpose Cleaning Brush | 22.2cm | N/A | WHT | 12 |

BOTTLE CLEANING BRUSHES

PRODUCT FEATURES:

1. Designed to clean the neck and other hard-to-reach part of bottles, jars, kettles and cups.
2. Comfortable plastic handle is easy to use.
3. Materials meet FDA requirements.
4. Handle with hang-up hole for easy storage.



5701

| Model | Description | Dimensions | Capacity | Color | Pack |
|-------|-----------------------|------------|----------|-------|------|
| 5701 | Bottle Cleaning Brush | 38.0cm | N/A | WHT | 12 |
| 5702 | Bottle Cleaning Brush | 65.0cm | N/A | WHT | 12 |



PIPE CLEANING BRUSHES

PRODUCT FEATURES:

1. Designed to clean the nozzle of various containers and funnels.
2. Nylon bristles.
3. Materials meet FDA requirements.



| Model | Description | Dimensions | Capacity | Color | Pack |
|-------|-------------------------------|------------|----------|-------|------|
| 5721 | 0.6cm Pipe Cleaning Brush | 16.5cm | N/A | WHT | 12 |
| 5722 | 1.0cm Pipe Cleaning Brush | 20.3cm | N/A | WHT | 12 |
| 5723 | 1.9-3.8cm Pipe Cleaning Brush | 25.4cm | N/A | WHT | 12 |
| 5724 | 1.3-2.5cm Pipe Cleaning Brush | 30.5cm | N/A | WHT | 12 |

HIGH-TEMPERATURE CLEANING BRUSHES

PRODUCT FEATURES:

1. Designed to clean high-temperature equipment.
2. High-temperature resistant bristles can resist temperatures up to 260°C.
3. Enables cleaning of equipment that is still hot, saving time.
4. Holes on the tailend of handle are available for hanging and storage.
5. 5731 is fit for for cleaning in tight spaces.
6. 5732 and 5733 have an L-shaped end for quick cleaning of coiled equipment.
7. 5734 has a loop-end, fit for cleaning the bottom of devices.

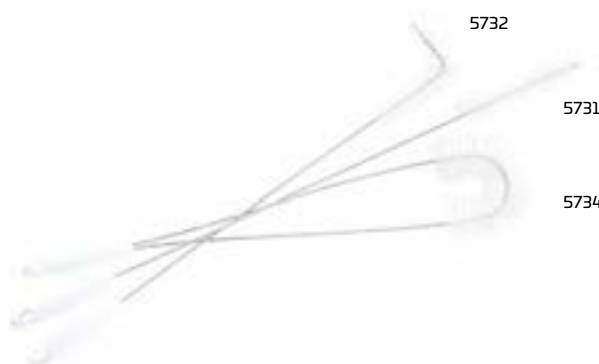

| Model | Description | Dimensions | Capacity | Color | Pack |
|-------|---|------------|----------|-------|------|
| 5731 | 3.5cm High Temperature Cleaning Brush | 71.0cm | N/A | WHT | 12 |
| 5732 | 2.2cm L-shaped High-temperature Cleaning Brush | 54.0cm | N/A | WHT | 12 |
| 5733 | 5.0cm L-shaped High-temperature Cleaning Brush | 58.0cm | N/A | WHT | 12 |
| 5734 | 5.0cm Ring-shaped High-temperature Cleaning Brush | 61.0cm | N/A | WHT | 6 |

COFFEE MACHINE CLEANING BRUSHES

PRODUCT FEATURES:

1. Designed to clean coffee machines and glass coffee bottles.
2. Semi-circular shape is suitable for cleaning the internal surface of coffee machines.
3. A hole on the tail end of the handle is for hanging and storage.

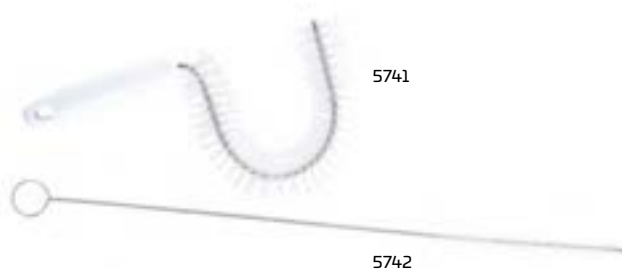

| Model | Description | Dimensions | Capacity | Color | Pack |
|-------|--|------------|----------|-------|------|
| 5741 | 3.8cm Semicircular Coffee Machine Cleaning Brush | 25.4cm | N/A | WHT | 12 |
| 5742 | 1.6cm Coffee Machine Cleaning Brush | 63.5cm | N/A | WHT | 12 |

GLASS BRUSHES

PRODUCT FEATURES:

1. Designed for cleaning glasses.
2. Plastic construction helps prevent glasses from being chipped or broken.
3. Molded plastic base with positive-suction provide a tight grip in sinks and on countertops.



6727



6728

| Model | Description | Dimensions | Capacity | Color | Pack |
|-------|---------------------------|----------------------|----------|-------|------|
| 6727 | Three Heads Glass Brush | 35.0 × 10.5 × 20.0cm | N/A | BLA | 6 |
| 6728 | Two Heads Glass Brush | 20.0 × 9.0 × 20.0cm | N/A | BLA | 6 |
| 6729 | Standard Glass Brush Head | Dia 7.5 × 19.5cm | N/A | BLA | 12 |

PROFESSIONAL PLASTIC SQUEEGEES



PRODUCT FEATURES:

1. Pre-treated polypropylene resists corrosion.
2. Twin black porous foam blades.
3. For removing liquids, moderate dirt.
4. Rubber resists oils, greases and most chemicals.
5. Fits 6351 broom handle which is sold separately.



6831

| Model | Description | Dimensions | Capacity | Color | Pack |
|-------|---|--------------------|----------|---------------------|------|
| 6831 | Plastic Professional Squeegee with Black Dual Moss Rubber | 45.7 × 5.8 × 8.9cm | N/A | BLUE, GRN, RED, YEL | 10 |



U-RAG® SUPERFINE FIBER CLOTHS



PRODUCT FEATURES:

1. Superfine fiber cloth offers optimized cleaning performance.
2. Rinsable and reusable, resist wash up to 40 times.
3. Bleach cleaning safe.
4. 30% higher decontamination capabilities than a cotton rag.
5. Removes more than 99.9% of bacteria and dirt.
6. Reduces the use of chemical cleansers.
7. Extends service life, reduces the use of paper towels.



6481/6482/6483/6484

| Model | Description | Dimensions | Capacity | Color | Pack |
|-------|------------------------------|---------------|----------|-------|------|
| 6481 | U-RAG® Superfine Fiber Cloth | 48.3 × 40.6cm | N/A | RED | 144 |
| 6482 | U-RAG® Superfine Fiber Cloth | 48.3 × 40.6cm | N/A | YEL | 144 |
| 6483 | U-RAG® Superfine Fiber Cloth | 48.3 × 40.6cm | N/A | BLUE | 144 |
| 6484 | U-RAG® Superfine Fiber Cloth | 48.3 × 40.6cm | N/A | GRN | 144 |

CLEANING TOOL HOLDERS



PRODUCT FEATURES:

1. Helps increase productivity and efficiency through better tool storage and access.
2. S-hooks hold 1.6cm to 3.2cm handle diameters.
3. Special hooks afford easy accessibility.
4. Includes a clip for holding record books.
5. 25113, 25114 and 25115 aluminum alloy material, light and never rusty. Used with stuck clips, hooks and signboards.
6. 25116 is suitable for fixing handles with a diameter of 22-32mm.
7. 25117 is suitable for fixing handles with a diameter of 28-38mm.
8. 25118 is suitable for fixing cleaning tools with hanging holes.
9. 25119 can be used with the base of the aluminum alloy tool rack, which can identify the hanging tools at each position clearly.



6942



6941



25114/25117/25116/25118/25119



| Model | Description | Dimensions | Capacity | Color | Pack |
|-------|--|---------------------|----------|----------------------|------|
| 6941 | Closet Organizer/Tool Holder Kit | 45.7 × 8.3 × 10.8cm | N/A | BLUE, GRN, RED, YEL | 6 |
| 6942 | Closet Organizer/Tool Holder Kit | 86.4 × 8.3 × 10.8cm | N/A | BLUE, GRN, RED, YEL | 4 |
| 25113 | HEDGEHOG® Cleaning Tool Rack Base, 300mm | 30.0 × 5.0 × 1.0cm | N/A | BLUE, VGRN, RED, GLD | 12 |
| 25114 | HEDGEHOG® Cleaning Tool Rack Base, 500mm | 50.0 × 5.0 × 1.0cm | N/A | BLUE, VGRN, RED, GLD | 12 |
| 25115 | HEDGEHOG® Cleaning Tool Rack Base, 900mm | 90.0 × 5.0 × 1.0cm | N/A | BLUE, VGRN, RED, GLD | 12 |
| 25116 | HEDGEHOG® Small Stuck Clip | 8.0 × 8.0 × 3.6cm | N/A | BLUE, VGRN, RED, GLD | 12 |
| 25117 | HEDGEHOG® Large Stuck Clip | 8.5 × 8.0 × 3.6cm | N/A | BLUE, VGRN, RED, GLD | 12 |
| 25118 | HEDGEHOG® Hook | 4.0 × 4.4 × 3.3cm | N/A | BLUE, VGRN, RED, GLD | 12 |
| 25119 | HEDGEHOG® Signboard | 11.2 × 12.5 × 0.9cm | N/A | BLUE, VGRN, RED, GLD | 12 |



SAFETY SIGNS

| | |
|---------------------------|-----|
| Floor Safety Signs | 268 |
| Four-sided Billboards | 268 |
| Stable Safety Signs | 269 |
| Hanging Safety Signs | 269 |
| Site Safety Hanging Signs | 269 |

SAFETY CONES AND ACCESSORIES

| | |
|----------------------|-----|
| Movable Fences | 270 |
| Safety Cones | 271 |
| Pop-up Safety Cones | 272 |
| Folding Safety Cones | 272 |



Keep Your Workplace Safe

TRUST has multiple solutions to ensure safety at your workplace.

Innovative Design

We understand that every workplace is different. Trust have developed products to suit every need.





FLOOR SAFETY SIGNS



PRODUCT FEATURES:

1. Lightweight and versatile; draws clear attention to a safety issue.
2. Folding design for convenient storage and to minimize space.
3. Built-in hook for hanging a weight.
4. Custom imprint for various sites.
5. Allows for hanging on Cleaning Cart (5011) or All-in-one Bucket (5211).
6. Custom print available by contacting your local dealer.



7114

| Model | Description | Dimensions | Capacity | Color | Pack |
|-------|---|----------------------|----------|-------|------|
| 7114 | Floor Safety Sign with "Caution Wet Floor" Imprint | 66.0 × 27.9 × 30.5cm | N/A | YEL | 6 |
| 7161 | Floor Safety Sign with "Repair in Progress" Imprint | 66.0 × 27.9 × 30.5cm | N/A | YEL | 6 |
| 7162 | Floor Safety Sign with "Cleaning in Progress" Imprint | 66.0 × 27.9 × 30.5cm | N/A | YEL | 6 |
| 7163 | Floor Safety Sign with "Out of Service" Imprint | 66.0 × 27.9 × 30.5cm | N/A | YEL | 6 |

FOUR-SIDED BILLBOARDS



PRODUCT FEATURES:

1. Folding design for convenient storage and to minimize space.
2. Innovative four-sided design can increase the stability of product.
3. Four-sided design improves safety with increased visibility from all directions.
4. Custom printing available. Please contact your local dealer.



7176



7177



7178

| Model | Description | Dimensions | Capacity | Color | Pack |
|-------|---|----------------------|----------|-------|------|
| 7175 | Four-sided Billboard - Caution Wet Floor | 40.0 × 30.0 × 90.0cm | N/A | YEL | 6 |
| 7176 | Four-sided Billboard - Cleaning in Progress | 40.0 × 30.0 × 90.0cm | N/A | YEL | 6 |
| 7177 | Four-sided Billboard - Out of Service | 40.0 × 30.0 × 90.0cm | N/A | YEL | 6 |
| 7178 | Four-sided Billboard - Repair in Progress | 40.0 × 30.0 × 90.0cm | N/A | YEL | 6 |



STABLE SAFETY SIGNS

PRODUCT FEATURES:

1. Unique “No-tip” design and bold graphics quickly capture pedestrian’s attention.
2. Designed for convenient storage - transport on Cleaning Cart (5011) or Rim Caddy (1821).
3. Large warning triangle with bold graphics.
4. Only 3.8cm thick when stored.
5. Self-opening feet give sign a large, stable base.
6. Low center of gravity helps prevent tipping when bumped, kicked or wind blown.
7. Custom printing available, please contact your local dealer.



7133

| Model | Description | Dimensions | Capacity | Color | Pack |
|-------|---|---|----------|-------|------|
| 7133 | Stable Safety Sign with “Caution Wet Floor” Imprint | Open: 66.0 × 33.0 × 33.6cm Closed: 82.0 × 33.0 × 3.8 | N/A | YEL | 6 |

HANGING SAFETY SIGNS



PRODUCT FEATURES:

1. Flexible locking hanger keeps sign in place.
2. Two-sided fluorescent yellow design.



7142



| Model | Description | Dimensions | Capacity | Color | Pack |
|-------|--|---------------|----------|-------|------|
| 7142 | Hanging Safety Sign with “Caution Wet Floor” Imprint | 49.5 × 11.1cm | N/A | YEL | 6 |

SITE SAFETY HANGING SIGNS



PRODUCT FEATURES:

1. Twisting action secures pole in doorways up to 127cm wide to prevent entry.
2. Soft, pliable sign rolls up on pole for easy storage.



7152

| Model | Description | Dimensions | Capacity | Color | Pack |
|-------|---|---|----------|-------|------|
| 7152 | Site Safety Hanging Sign with “Closed for Cleaning” Imprint | Closed: 33.0 × 63.5 × 2.5cm Open: 33.0 × 127.0 × 2.5cm | N/A | YEL | 6 |

SAFETY CONES AND ACCESSORIES



MOVABLE FENCES

PRODUCT FEATURES:

1. Movable fences for easy use, movement and storage.
2. For indoor use, flexible panels allow straight, curved, and circular configurations.
3. After folding, the thickness of the fence is 18.4-34.9cm, provides easy storage, saving space.
4. The fence is equipped with two 12.5cm non-marking casters for efficient and ergonomic movement.
5. Highly visible mobile barrier for use in many situations.
6. Shipped assembled.



7182

7181

| Model | Description | Dimensions | Capacity | Color | Pack |
|-------|---|--|----------|-------|------|
| 7181 | Movable Fence, Consisting of 16 Connecting Plates | Close: 34.9 × 60.0 × 100.0cm Open: 398.0 × 60.0 × 100.0cm | N/A | YEL | 1 |
| 7182 | Movable Fence, Consisting of 12 Connecting Plates | Close: 26.6 × 60.0 × 100.0cm Open: 278.0 × 60.0 × 100.0cm | N/A | YEL | 1 |
| 7183 | Movable Fence, Consisting of 8 Connecting Plates | Close: 18.4 × 60.0 × 100.0cm Open: 158.0 × 60.0 × 100.0cm | N/A | YEL | 1 |





SAFETY CONES

PRODUCT FEATURES:

1. Highly visible bright fluorescent yellow.
2. Versatile top design accommodates barricade belt, flashing light or a lock-in sign holder.
3. Slots across two opposing sides are designed for a barrier chain.
4. Four sided shape allows for efficient stacking.
5. Imprinting on four sides allows for a safety or alert message from all directions.
6. Custom messages to be printed for applications in different environment.
7. 7323 matched with 1812 for easy transit.
8. 7323 matched with 7521 for enhanced stability.



| Model | Description | Dimensions | Capacity | Color | Pack |
|-------|---|----------------------|----------|-------|------|
| 7313 | Safety Cone with "Caution, Wet Floor" Imprint | 26.7 × 26.7 × 65.4cm | N/A | YEL | 6 |
| 7315 | Safety Cone with "No Parking" Imprint | 26.7 × 26.7 × 65.4cm | N/A | YEL | 6 |
| 7323 | Safety Cone with "Caution, Wet Floor" Imprint | 31.1 × 31.1 × 91.4cm | N/A | YEL | 5 |
| 1812 | THOR® Square Dolly | 43.8 × 15.9cm | N/A | BLA | 2 |
| 7121 | Safety Cone Signs | 29.6 × 26.2 × 5.5cm | N/A | RED | 5 |
| 7122 | Safety Cone Signs with "No Parking" Imprint | 29.6 × 26.2 × 5.5cm | N/A | RED | 5 |
| 7511 | Barrier Chain | 2.2 × 2.2 × 610.0cm | N/A | YEL | 4 |
| 7512 | Safety Warning Light | 8.6 × 13.5cm | N/A | YEL | 12 |
| 7521 | Weight Ring-Single for 7323 | 31.8 × 31.8 × 8.0cm | N/A | BLA | 1 |





POP-UP SAFETY CONES

PRODUCT FEATURES:

1. Convenient, quick deployment when hazard arises.
2. Collapsible, automatically deployed cone.
3. Wall-mounted, shatter proof, storage tube allows for easily and compact storing.
4. Durable material withstands abuse.
5. Storage tube mounting hardware includes tape and screws.



7333

| Model | Description | Dimensions | Capacity | Color | Pack |
|-------|--|--|----------|-------|------|
| 7333 | Pop-Up Safety Cone, 50cm with "Caution, Wet Floor" Imprint | Dia 53.3 x 50.8cm Shell: 7.4 x 6.0 x 57.0cm | N/A | YEL | 12 |
| 7334 | Pop-Up Safety Cone, 76cm with "Caution, Wet Floor" Imprint | Dia 53.3 x 76.2cm Shell: 7.4 x 6.0 x 82.2cm | N/A | YEL | 12 |

FOLDING SAFETY CONES



PRODUCT FEATURES:

1. Space-saving storage container can be installed flat against the wall.
2. Folds easily and quickly after use.
3. Can be hung on the handle of Bucket Wringer (5226) with the compatible ring.
4. Made of spring steel and cleanable fabric.
5. Area is 51 x 46cm when opened; only 22.8cm diameter when folded.



7342



| Model | Description | Dimensions | Capacity | Color | Pack |
|-------|---|--|----------|-------|------|
| 7342 | Folding Safety Cone with "Caution, Wet Floor" Imprint | Open: 50.8 x 46.6 x 33.0cm Close: 20.3 x 20.3 x 3.8cm Shell: 20.3 x 22.2 x 4.4cm | N/A | YEL | 12 |



PRODUCT INDEX

| No. | Product Name | Pack | Color | Order Code | Color | Order Code | Page |
|------|--|------|-------|------------|-------|------------|------------|
| 1009 | Thor® Round Container | 6 | GRAY | 610098881 | GRN | 610098884 | 10 |
| | | | WHT | 610098882 | RED | 610098885 | |
| | | | YEL | 610098883 | BLUE | 610098886 | |
| | | | BRN | 610098887 | | | |
| 1010 | Thor® Round Container | 6 | GRAY | 610108881 | GRN | 610108884 | 10 |
| | | | WHT | 610108882 | RED | 610108885 | |
| | | | YEL | 610108883 | BLUE | 610108886 | |
| 1011 | Thor® Round Container | 6 | GRAY | 610118881 | GRN | 610118884 | 10 |
| | | | WHT | 610118882 | RED | 610118885 | |
| | | | YEL | 610118883 | BLUE | 610118886 | |
| | | | BRN | 610118887 | | | |
| 1012 | Thor® Round Container | 6 | GRAY | 610128881 | RED | 610128885 | 10 |
| | | | WHT | 610128882 | BLUE | 610128886 | |
| | | | YEL | 610128883 | BRN | 610128887 | |
| | | | GRN | 610128884 | BLA | 610128888 | |
| 1013 | Thor® Round Container | 6 | GRAY | 610138881 | RED | 610138885 | 10, 36 |
| | | | WHT | 610138882 | BLUE | 610138886 | |
| | | | YEL | 610138883 | BLA | 610138887 | |
| | | | GRN | 610138884 | BRN | 610138888 | |
| | | | LGRAY | 610138889 | | | |
| 1014 | Thor® Round Container | 4 | GRAY | 610148881 | RED | 610148885 | 10, 60, 79 |
| | | | WHT | 610148882 | BLUE | 610148886 | |
| | | | YEL | 610148883 | BLA | 610148887 | |
| | | | GRN | 610148884 | | | |
| 1015 | Thor® Round Container | 3 | GRAY | 610158881 | RED | 610158885 | 10 |
| | | | WHT | 610158882 | BLA | 610158886 | |
| | | | YEL | 610158883 | BLUE | 610158887 | |
| | | | GRN | 610158884 | | | |
| 1016 | Thor® Round Container | 6 | BLUE | 610168881 | | | 29 |
| 1017 | Thor® Round Container | 6 | BLUE | 610178881 | | | 29 |
| 1018 | Thor® Round Container | 4 | BLUE | 610188881 | | | 29 |
| 1019 | Round Case, with a Top | 6 | YEL | 610198881 | | | 41 |
| 1020 | Round Case, with a Top | 6 | YEL | 610208881 | | | 41 |
| 1021 | Thor® Rollout Container | 2 | GRAY | 610218881 | RED | 610218884 | 12 |
| | | | YEL | 610218882 | GRN | 610218885 | |
| | | | BLUE | 610218883 | | | |
| 1022 | Thor® Rollout Recycling Trash Bin with Cover | 2 | BLUE | 610228881 | | | 37 |
| 1025 | Thor® Rollout Container | 1 | GRAY | 610258881 | RED | 610258882 | 12 |
| 1026 | Thor® Rollout Recycling Bin, Rotomolded | 1 | BLUE | 610268881 | | | 37 |
| 1031 | Thor® Rollout Container | 2 | GRAY | 610318881 | BLUE | 610318884 | 13 |
| | | | RED | 610318882 | GRN | 610318885 | |
| | | | YEL | 610318883 | BLA | 610318886 | |
| 1032 | Thor® Rollout Container | 2 | GRAY | 610328881 | BLUE | 610328884 | 13 |
| | | | RED | 610328882 | GRN | 610328885 | |
| | | | YEL | 610328883 | BLA | 610328886 | |
| 1033 | Thor® Rollout Container | 1 | GRAY | 610338881 | BLUE | 610338884 | 13 |
| | | | RED | 610338882 | GRN | 610338885 | |
| | | | YEL | 610338883 | BLA | 610338886 | |
| 1034 | Thor® Rollout Container | 1 | GRAY | 610348881 | BLUE | 610348884 | 13 |
| | | | RED | 610348882 | GRN | 610348885 | |
| | | | YEL | 610348883 | BLA | 610348886 | |
| 1035 | Thor® Step-On Rollout Container | 1 | GRAY | 610358881 | BLUE | 610358884 | 14, 24 |
| | | | RED | 610358882 | GRN | 610358885 | |
| | | | YEL | 610358883 | BLA | 610358886 | |
| 1036 | Thor® Step-On Rollout Container | 1 | GRAY | 610368881 | BLUE | 610368884 | 14, 24 |
| | | | RED | 610368882 | GRN | 610368885 | |
| | | | YEL | 610368883 | BLA | 610368886 | |
| 1037 | Thor® Step-On Rollout Container | 1 | GRAY | 610378881 | BLUE | 610378884 | 14, 24 |
| | | | RED | 610378882 | GRN | 610378885 | |
| | | | YEL | 610378883 | BLA | 610378886 | |
| 1038 | Thor® Step-On Rollout Container | 1 | GRAY | 610388881 | BLUE | 610388884 | 14, 24 |
| | | | RED | 610388882 | GRN | 610388885 | |
| | | | YEL | 610388883 | BLA | 610388886 | |

| No. | Product Name | Pack | Color | Order Code | Color | Order Code | Page |
|------|--|------|-------|------------|-------|------------|----------------------------------|
| 1041 | Thor® Rollout Container with Casters | 2 | GRAY | 610418881 | BLUE | 610418884 | 13 |
| | | | RED | 610418882 | GRN | 610418885 | |
| | | | YEL | 610418883 | BLA | 610418886 | |
| 1042 | Thor® Rollout Container with Casters | 2 | GRAY | 610428881 | BLUE | 610428884 | 13 |
| | | | RED | 610428882 | GRN | 610428885 | |
| | | | YEL | 610428883 | BLA | 610428886 | |
| 1043 | Thor® Rollout Container with Casters | 1 | GRAY | 610438881 | BLUE | 610438884 | 13 |
| | | | RED | 610438882 | GRN | 610438885 | |
| | | | YEL | 610438883 | BLA | 610438886 | |
| 1044 | Thor® Rollout Container with Casters | 1 | GRAY | 610448881 | BLUE | 610448884 | 13 |
| | | | RED | 610448882 | GRN | 610448885 | |
| | | | YEL | 610448883 | BLA | 610448886 | |
| 1045 | Thor® Step-On Rollout Container with Casters | 1 | GRAY | 610458881 | BLUE | 610458884 | 14, 24 |
| | | | RED | 610458882 | GRN | 610458885 | |
| | | | YEL | 610458883 | BLA | 610458886 | |
| 1046 | Thor® Step-On Rollout Container with Casters | 1 | GRAY | 610468881 | BLUE | 610468884 | 14, 24 |
| | | | RED | 610468882 | GRN | 610468885 | |
| | | | YEL | 610468883 | BLA | 610468886 | |
| 1047 | Thor® Step-On Rollout Container with Casters | 1 | GRAY | 610478881 | BLUE | 610478884 | 14, 24 |
| | | | RED | 610478882 | GRN | 610478885 | |
| | | | YEL | 610478883 | BLA | 610478886 | |
| 1048 | Thor® Step-On Rollout Container with Casters | 1 | GRAY | 610488881 | BLUE | 610488884 | 14, 24 |
| | | | RED | 610488882 | GRN | 610488885 | |
| | | | YEL | 610488883 | BLA | 610488886 | |
| 1211 | Svelte® Slim Rectangle Container | 4 | GRAY | 612118881 | BLUE | 612118883 | 18, 31, 32, 73 |
| | | | GRN | 612118882 | BEIG | 612118884 | |
| | | | BRN | 612118885 | BLA | 612118886 | |
| | | | LGRAY | 612118887 | RED | 612118888 | |
| | | | YEL | 612118889 | | | |
| 1212 | Svelte® Slim Rectangle Recycling Container | 4 | BLUE | 612128881 | GRN | 612128882 | 30 |
| 1213 | Svelte® Slim Rectangle Container | 4 | BEIG | 612138881 | BLUE | 612138884 | 18, 31, 32, 62, 71, 73, 78 |
| | | | BRN | 612138882 | GRN | 612138885 | |
| | | | GRAY | 612138883 | BLA | 612138886 | |
| | | | LGRAY | 612138887 | RED | 612138888 | |
| | | | YEL | 612138889 | | | |
| 1214 | Svelte® Slim Rectangle Recycling Container | 4 | BLUE | 612148881 | GRN | 612148882 | 30 |
| 1215 | Svelte® Slim Rectangle Container | 4 | GRAY | 612158881 | BEIG | 612158884 | 16, 33, 34, 71 |
| | | | BLUE | 612158882 | BRN | 612158885 | |
| | | | GRN | 612158883 | BLA | 612158886 | |
| | | | LGRAY | 612158887 | RED | 612158888 | |
| | | | YEL | 612158889 | | | |
| 1216 | Caster Set for 1215 | 1 | BLA | 612168881 | | | 16 |
| 1217 | Svelte® Recycling Container | 4 | BLUE | 612178881 | GRN | 612178882 | 30 |
| 1218 | Garbage Classification Fixing Device for 1212/1214 | 1 | BLA | 612188881 | | | 30 |
| 1219 | Classification Collection Lid for 1641 | 4 | RED | 612198881 | BLUE | 612198883 | 30 |
| | | | YEL | 612198882 | GRN | 612198884 | |
| 1220 | Svelte® Container | 4 | BLA | 612208881 | GRAY | 612208885 | 18, 31, 32, 62, 78 |
| | | | BEIG | 612208882 | BLUE | 612208886 | |
| | | | BRN | 612208883 | GRN | 612208887 | |
| | | | RED | 612208884 | YEL | 612208888 | |
| | | | LGRAY | 612208889 | | | |
| 1221 | Svelte® Recycling Container | 4 | BLUE | 612218881 | GRN | 612218882 | 30 |
| 1223 | Half-round Container | 4 | BEIG | 612238881 | GRAY | 612238882 | 25 |
| 1224 | Half-round Recycling Container | 4 | BLUE | 612248881 | | | 30 |
| 1231 | Square Container | 6 | GRAY | 612318881 | RED | 612318883 | 12, 187 |
| | | | WHT | 612318882 | | | |
| 1233 | Square Container | 4 | GRAY | 612338881 | WHT | 612338882 | 12, 187 |
| 1234 | Square Recycling Container | 4 | BLUE | 612348881 | | | 29 |
| 1235 | Square Case, with a Top | 6 | YEL | 612358881 | | | 41 |
| 1236 | Square Case, with a Top | 4 | YEL | 612368881 | | | 41 |
| 1241 | Side Bin Recycling Center | 12 | GRAY | 612418881 | GRN | 612418883 | 26, 38 |
| | | | BLA | 612418882 | BLUE | 612418884 | |
| 1242 | Wastebasket, Small | 12 | BLA | 612428881 | BEIG | 612428883 | 26 |
| | | | GRAY | 612428882 | | | |

PRODUCT INDEX

| No. | Product Name | Pack | Color | Order Code | Color | Order Code | Page |
|------|--------------------------------------|------|-------|------------|-------|------------|------------|
| 1243 | Wastebasket, Medium | 12 | BLA | 612438881 | BLUE | 612438884 | 26 |
| | | | GRAY | 612438882 | GRN | 612438885 | |
| | | | BEIG | 612438883 | | | |
| 1244 | Wastebasket, Large | 12 | BLA | 612448881 | BLUE | 612448884 | 26 |
| | | | GRAY | 612448882 | GRN | 612448885 | |
| | | | BEIG | 612448883 | | | |
| 1245 | Wastebasket, Large | 12 | BLA | 612458881 | BLUE | 612458884 | 26 |
| | | | GRAY | 612458882 | GRN | 612458885 | |
| | | | BEIG | 612458883 | | | |
| 1246 | Deskside Recycling Container, Small | 12 | BLUE | 612468881 | GRN | 612468882 | 38 |
| 1247 | Deskside Recycling Container, Medium | 12 | BLUE | 612478881 | GRN | 612478882 | 38 |
| 1248 | Deskside Recycling Container, Large | 12 | BLUE | 612488881 | | | 38 |
| 1249 | Deskside Recycling Container, Large | 12 | BLUE | 612498881 | | | 38 |
| 1250 | Step-on Container | 1 | YEL | 612508881 | | | 41 |
| 1251 | Step-on Container | 1 | WHT | 612518881 | BEIG | 612518883 | 21 |
| | | | RED | 612518882 | YEL | 612518884 | |
| | | | BLUE | 612518885 | | | |
| 1252 | Step-on Container | 1 | WHT | 612528881 | BEIG | 612528883 | 21 |
| | | | RED | 612528882 | YEL | 612528884 | |
| | | | BLUE | 612528885 | | | |
| 1253 | Step-on Container | 1 | WHT | 612538881 | BEIG | 612538883 | 21 |
| | | | RED | 612538882 | YEL | 612538884 | |
| | | | BLUE | 612538885 | | | |
| 1254 | Step-on Container | 1 | WHT | 612548881 | BEIG | 612548883 | 21 |
| | | | RED | 612548882 | YEL | 612548884 | |
| | | | BLUE | 612548885 | | | |
| 1255 | Rollout Step-on Container | 1 | WHT | 612558881 | BEIG | 612558883 | 21 |
| | | | RED | 612558882 | YEL | 612558884 | |
| | | | BLUE | 612558885 | | | |
| 1256 | Step-on Container | 1 | YEL | 612568881 | | | 41 |
| 1257 | Step-on Container | 1 | YEL | 612578881 | | | 41 |
| 1258 | Step-on Container | 1 | YEL | 612588881 | | | 41 |
| 1259 | Rollout Step-on Container | 1 | YEL | 612598881 | | | 41 |
| 1261 | UNIFIRE® Fire-resistant Wastebasket | 6 | BEIG | 612618881 | BLA | 612618882 | 26 |
| 1262 | UNIFIRE® Fire-resistant Wastebasket | 6 | GRAY | 612628881 | BEIG | 612628883 | 26 |
| | | | BLA | 612628882 | | | |
| 1263 | UNIFIRE® Fire-resistant Wastebasket | 6 | GRAY | 612638881 | BEIG | 612638883 | 26 |
| | | | BLA | 612638882 | | | |
| 1264 | UNIFIRE® Fire-resistant Wastebasket | 4 | BEIG | 612648881 | | | 26 |
| 1271 | Square Container | 4 | GRAY | 612718881 | BRN | 612718883 | 25, 35 |
| | | | BLA | 612718882 | BEIG | 612718884 | |
| | | | LGRAY | 612718885 | | | |
| 1281 | Square Container | 4 | GRAY | 612818881 | BRN | 612818883 | 25, 52 |
| | | | BLA | 612818882 | BEIG | 612818884 | |
| 1282 | Square Container | 4 | GRAY | 612828881 | BEIG | 612828882 | 25, 38, 52 |
| 1283 | Square Container | 4 | GRAY | 612838881 | BEIG | 612838882 | 25 |
| 1284 | Square Container | 4 | GRAY | 612848881 | | | 25, 52 |
| 1291 | Round Wastebasket | 6 | MSILV | 612918881 | BLA | 612918882 | 27 |
| 1292 | Square Wastebasket | 3 | MSILV | 612928881 | | | 27 |
| 1293 | Rectangular Wastebasket | 3 | BLA | 612938881 | | | 27 |
| 1301 | Svelte® Step-on Container | 1 | BEIG | 613018881 | YEL | 613018885 | 23 |
| | | | WHT | 613018882 | BLUE | 613018886 | |
| | | | GRAY | 613018883 | GRN | 613018887 | |
| | | | RED | 613018884 | BLA | 613018888 | |
| 1302 | Svelte® Step-on Container | 1 | BEIG | 613028881 | YEL | 613028885 | 23 |
| | | | WHT | 613028882 | BLUE | 613028886 | |
| | | | GRAY | 613028883 | GRN | 613028887 | |
| | | | RED | 613028884 | BLA | 613028888 | |
| 1303 | Svelte® Step-on Container | 1 | BEIG | 613038881 | YEL | 613038885 | 23 |
| | | | WHT | 613038882 | BLUE | 613038886 | |
| | | | GRAY | 613038883 | GRN | 613038887 | |
| | | | RED | 613038884 | BLA | 613038888 | |

| No. | Product Name | Pack | Color | Order Code | Color | Order Code | Page |
|------|--|------|-------|------------|-------|------------|------|
| 1304 | Svelte® Step-on Container | 1 | BEIG | 613048881 | YEL | 613048885 | 23 |
| | | | WHT | 613048882 | BLUE | 613048886 | |
| | | | GRAY | 613048883 | GRN | 613048887 | |
| | | | RED | 613048884 | BLA | 613048888 | |
| 1305 | Svelte® Step-on Container | 1 | BEIG | 613058881 | YEL | 613058885 | 22 |
| | | | WHT | 613058882 | BLUE | 613058886 | |
| | | | GRAY | 613058883 | GRN | 613058887 | |
| | | | RED | 613058884 | BLA | 613058888 | |
| 1306 | Svelte® Step-on Container | 1 | BEIG | 613068881 | YEL | 613068885 | 22 |
| | | | WHT | 613068882 | BLUE | 613068886 | |
| | | | GRAY | 613068883 | GRN | 613068887 | |
| | | | RED | 613068884 | BLA | 613068888 | |
| 1307 | Svelte® Step-on Container | 1 | BEIG | 613078881 | YEL | 613078885 | 22 |
| | | | WHT | 613078882 | BLUE | 613078886 | |
| | | | GRAY | 613078883 | GRN | 613078887 | |
| | | | RED | 613078884 | BLA | 613078888 | |
| 1308 | Svelte® Step-on Container | 1 | BEIG | 613088881 | YEL | 613088885 | 22 |
| | | | WHT | 613088882 | BLUE | 613088886 | |
| | | | GRAY | 613088883 | GRN | 613088887 | |
| | | | RED | 613088884 | BLA | 613088888 | |
| 1309 | Svelte® Step-on Container | 1 | BEIG | 613098881 | YEL | 613098885 | 22 |
| | | | WHT | 613098882 | BLUE | 613098886 | |
| | | | GRAY | 613098883 | GRN | 613098887 | |
| | | | RED | 613098884 | BLA | 613098888 | |
| 1310 | Round Stainless Steel Step-on Container | 1 | SSS | 613108881 | | | 48 |
| 1311 | Round Stainless Steel Step-on Container | 1 | SSS | 613118881 | | | 48 |
| 1312 | Round Stainless Steel Step-on Container | 1 | SSS | 613128881 | | | 48 |
| 1313 | Round Stainless Steel Step-on Container | 1 | SSS | 613138881 | | | 48 |
| 1314 | Svelte® Stainless Steel Step-on Container | 1 | SSS | 613148881 | | | 50 |
| 1315 | Svelte® Stainless Steel Step-on Container | 1 | SSS | 613158881 | | | 50 |
| 1316 | Svelte® Stainless Steel Step-on Container | 1 | SSS | 613168881 | | | 50 |
| 1317 | Svelte® Stainless Steel Step-on Container | 1 | SSS | 613178881 | | | 50 |
| 1318 | Domed Open Trash Can | 1 | BLA | 613188881 | | | 48 |
| 1319 | Top Open Trash Can | 1 | SS | 613198881 | | | 48 |
| 1320 | Semicircular Stainless Steel Step-on Trash Can | 1 | SSS | 613208881 | | | 50 |
| 1321 | Semicircular Stainless Steel Step-on Trash Can | 1 | SSS | 613218881 | | | 50 |
| 1322 | Round Stainless Steel Step-on Container | 1 | SSS | 613228881 | | | 49 |
| 1323 | Round Stainless Steel Step-on Container | 1 | SSS | 613238881 | | | 49 |
| 1324 | Round Stainless Steel Step-on Container | 1 | SSS | 613248881 | | | 49 |
| 1325 | Round Stainless Steel Step-on Container | 1 | SSS | 613258881 | | | 49 |
| 1326 | Round Stainless Steel Step-on Container | 1 | SSS | 613268881 | | | 49 |
| 1327 | Round Stainless Steel Step-on Container | 1 | SSS | 613278881 | | | 49 |
| 1411 | Rigid Liner for 1251 | 2 | GRAY | 614118881 | | | 21 |
| 1412 | Rigid Liner for 1252 | 2 | GRAY | 614128881 | | | 21 |
| 1413 | Rigid Liner for 1253 | 2 | GRAY | 614138881 | | | 21 |
| 1414 | Rigid Liner for 1254 | 4 | GRAY | 614148881 | | | 21 |
| 1415 | Rigid Liner for 1255 | 4 | GRAY | 614158881 | | | 21 |
| 1421 | Rigid Liner for 1301 | 2 | BLA | 614218881 | | | 23 |
| 1422 | Rigid Liner for 1302 | 2 | BLA | 614228881 | | | 23 |
| 1423 | Rigid Liner for 1303 | 2 | BLA | 614238881 | | | 23 |
| 1424 | Rigid Liner for 1304 | 2 | BLA | 614248881 | | | 23 |
| 1425 | Rigid Liner for 1305 | 2 | BLA | 614258881 | | | 22 |
| 1426 | Rigid Liner for 1306 | 2 | BLA | 614268881 | | | 22 |
| 1427 | Rigid Liner for 1307 | 2 | BLA | 614278881 | | | 22 |
| 1428 | Rigid Liner for 1308 | 2 | BLA | 614288881 | | | 22 |
| 1429 | Rigid Liner for 1309 | 2 | BLA | 614298881 | | | 22 |
| 1609 | Thor® Lid for 1009 | 6 | GRAY | 616098881 | GRN | 616098884 | 11 |
| | | | WHT | 616098882 | RED | 616098885 | |
| | | | YEL | 616098883 | BLUE | 616098886 | |
| | | | BLA | 616098887 | BRN | 616098889 | |
| 1610 | Thor® Lid for 1010 | 6 | GRAY | 616108881 | GRN | 616108884 | 11 |
| | | | WHT | 616108882 | RED | 616108885 | |
| | | | YEL | 616108883 | BLUE | 616108886 | |

PRODUCT INDEX

| No. | Product Name | Pack | Color | Order Code | Color | Order Code | Page |
|------|---|------|-------|------------|-------|------------|------------|
| 1611 | Thor® Lid for 1011 | 6 | GRAY | 616118881 | GRN | 616118884 | 11 |
| | | | RED | 616118882 | WHT | 616118885 | |
| | | | YEL | 616118883 | BLU | 616118886 | |
| | | | BRN | 616118887 | BLA | 616118888 | |
| 1612 | Thor® Lid for 1012 | 6 | GRAY | 616128881 | GRN | 616128885 | 11 |
| | | | WHT | 616128882 | RED | 616128886 | |
| | | | YEL | 616128883 | BLA | 616128887 | |
| | | | BLU | 616128884 | BRN | 616128888 | |
| 1613 | Thor® Lid for 1013 | 6 | GRAY | 616138881 | GRN | 616138884 | 11 |
| | | | WHT | 616138882 | BLA | 616138885 | |
| | | | YEL | 616138883 | BLU | 616138886 | |
| | | | RED | 616138887 | BRN | 616138888 | |
| 1614 | Thor® Lid for 1014 | 4 | GRAY | 616148881 | GRN | 616148884 | 11 |
| | | | WHT | 616148882 | BLA | 616148885 | |
| | | | YEL | 616148883 | BLU | 616148886 | |
| | | | RED | 616148887 | | | |
| 1615 | Thor® Lid for 1015 | 3 | GRAY | 616158881 | | | 11 |
| 1621 | Thor® Funnel Top for 1011 | 6 | GRAY | 616218881 | BLU | 616218882 | 10 |
| | | | GRN | 616218883 | | | |
| 1622 | Thor® Funnel Top for 1012 | 6 | GRAY | 616228881 | BLU | 616228882 | 10, 29 |
| | | | GRN | 616228883 | | | |
| 1623 | Thor® Funnel Top for 1013 | 4 | GRAY | 616238881 | BLU | 616238882 | 10, 29 |
| | | | GRN | 616238883 | | | |
| 1633 | Thor® Lid for 1013 | 1 | GRAY | 616338881 | RED | 616338882 | 11 |
| 1634 | Thor® Round Top with an ashtray for 1013 | 1 | GRAY | 616348881 | RED | 616348882 | 11 |
| 1635 | Thor® Bottle and Can Recycling Top for 1013 | 6 | BLU | 616358881 | GRN | 616358882 | 11, 29 |
| 1636 | Thor® Paper Recycling Top for 1013 | 6 | BLU | 616368881 | GRN | 616368882 | 11, 29 |
| 1637 | Thor® Single Stream Recycling Top for 1013 | 6 | BLU | 616378881 | GRN | 616378882 | 11, 29 |
| 1641 | Bottle and Can Recycling Top | 4 | BLU | 616418881 | GRN | 616418882 | 18, 30 |
| | | | RED | 616418883 | YEL | 616418884 | |
| | | | BRN | 616418885 | BLA | 616418886 | |
| | | | GRAY | 616418887 | | | |
| 1642 | Paper Recycling Top | 4 | BLU | 616428881 | RED | 616428882 | 18, 30 |
| | | | GRN | 616428883 | | | |
| 1643 | Handle Top | 4 | LGRAY | 616438881 | | | 18 |
| 1644 | Swing Lid | 4 | GRAY | 616448881 | BLU | 616448883 | 18 |
| | | | BLA | 616448882 | BEIG | 616448884 | |
| | | | GRN | 616448885 | | | |
| 1645 | Connect Valve Style Lid | 4 | BLA | 616458881 | | | 18, 71, 73 |
| 1646 | Single Stream Recycling Top | 4 | GRN | 616468881 | | | 18, 30 |
| 1647 | Svelte® Bottle and Can Recycling Top for 1215 | 4 | BLU | 616478881 | GRN | 616478882 | 17, 30 |
| 1648 | Svelte® Paper Recycling Top for 1215 | 4 | BLU | 616488881 | | | 17, 30 |
| 1649 | Svelte® Handle Top for 1215 | 4 | LGRAY | 616498881 | | | 17 |
| 1650 | Svelte® Swing Lid for 1215 | 4 | GRAY | 616508881 | BEIG | 616508884 | 17 |
| | | | BLA | 616508882 | GRN | 616508885 | |
| | | | BLU | 616508883 | | | |
| 1651 | Svelte® Lockable Lid for 1215 | 4 | BLA | 616518881 | BLU | 616518883 | 17 |
| | | | GRAY | 616518882 | GRN | 616518884 | |
| | | | BEIG | 616518885 | | | |
| 1653 | Half-round Top for 1223 | 4 | BLA | 616538881 | GRAY | 616538882 | 25 |
| | | | BEIG | 616538883 | | | |
| 1661 | Thor® Lid for 1231 | 6 | GRAY | 616618881 | WHT | 616618883 | 12, 187 |
| | | | RED | 616618882 | | | |
| 1663 | Thor® Lid for 1233 | 4 | GRAY | 616638881 | WHT | 616638882 | 12, 187 |
| 1672 | Hand-free Top for 1242 | 6 | BLA | 616728881 | BEIG | 616728882 | 26 |
| | | | GRAY | 616728883 | | | |
| 1673 | Hand-free Top for 1243 | 6 | BLA | 616738881 | BEIG | 616738882 | 26 |
| | | | GRAY | 616738883 | | | |
| 1674 | Hand-free Top for 1244 | 6 | BLA | 616748881 | BEIG | 616748882 | 26 |
| | | | GRAY | 616748883 | | | |
| 1681 | Square Top for 1271 | 4 | GRAY | 616818881 | BEIG | 616818883 | 25 |
| 1682 | Bottle/Tin Recycling Top for 1271 | 4 | BLU | 616828881 | GRN | 616828882 | 25 |
| | | | RED | 616828883 | | | |
| 1683 | Paper Recycling Top for 1271 | 4 | BLU | 616838881 | GRN | 616838882 | 25 |
| 1684 | Bottle/Tin Recycling Top for 1282 | 4 | BLU | 616848881 | GRN | 616848882 | 25 |

| No. | Product Name | Pack | Color | Order Code | Color | Order Code | Page |
|------|---------------------------------------|------|-------|------------|-------|------------|------|
| 1685 | Paper Recycling Top for 1282 | 4 | BLUE | 616858881 | GRN | 616858882 | 25 |
| 1700 | Lid for 1211/1213 | 4 | LGRAY | 617008881 | | | 31 |
| 1701 | Paper Recycling Top for 1700 | 4 | GRAY | 617018881 | BLUE | 617018884 | 31 |
| | | | RED | 617018882 | GRN | 617018885 | |
| | | | YEL | 617018883 | BLA | 617018886 | |
| | | | BRN | 617018887 | | | |
| 1702 | Bottle and Can Recycling Top for 1700 | 4 | GRAY | 617028881 | BLUE | 617028884 | 31 |
| | | | RED | 617028882 | GRN | 617028885 | |
| | | | YEL | 617028883 | BLA | 617028886 | |
| | | | BRN | 617028887 | | | |
| 1703 | Paper/Bottle Recycling Top for 1700 | 4 | GRAY | 617038881 | BLUE | 617038884 | 31 |
| | | | RED | 617038882 | GRN | 617038885 | |
| | | | YEL | 617038883 | BLA | 617038886 | |
| | | | BRN | 617038887 | | | |
| 1704 | Enclosed Lid for 1700 | 4 | GRAY | 617048881 | BLUE | 617048884 | 31 |
| | | | RED | 617048882 | GRN | 617048885 | |
| | | | YEL | 617048883 | BLA | 617048886 | |
| | | | BRN | 617048887 | | | |
| 1710 | Top for 1211/1213 | 4 | LGRAY | 617108881 | | | 32 |
| 1711 | Paper Recycling Top for 1710 | 4 | GRAY | 617118881 | BLUE | 617118884 | 32 |
| | | | RED | 617118882 | GRN | 617118885 | |
| | | | YEL | 617118883 | BLA | 617118886 | |
| | | | BRN | 617118887 | | | |
| 1712 | Bottle Recycling Top for 1710 | 4 | GRAY | 617128881 | BLUE | 617128884 | 32 |
| | | | RED | 617128882 | GRN | 617128885 | |
| | | | YEL | 617128883 | BLA | 617128886 | |
| | | | BRN | 617128887 | | | |
| 1713 | Paper/Bottle Recycling Top for 1710 | 4 | GRAY | 617138881 | BLUE | 617138884 | 32 |
| | | | RED | 617138882 | GRN | 617138885 | |
| | | | YEL | 617138883 | BLA | 617138886 | |
| | | | BRN | 617138887 | | | |
| 1714 | Enclosed lid for 1710 | 4 | GRAY | 617148881 | BLUE | 617148884 | 32 |
| | | | RED | 617148882 | GRN | 617148885 | |
| | | | YEL | 617148883 | BLA | 617148886 | |
| | | | BRN | 617148887 | | | |
| 1720 | Top for 1271 | 4 | LGRAY | 617208881 | | | 35 |
| 1721 | Paper Recycling Top for 1720 | 4 | GRAY | 617218881 | BLUE | 617218884 | 35 |
| | | | RED | 617218882 | GRN | 617218885 | |
| | | | YEL | 617218883 | BLA | 617218886 | |
| | | | BRN | 617218887 | | | |
| 1722 | Bottle Recycling Top for 1720 | 4 | GRAY | 617228881 | BLUE | 617228884 | 35 |
| | | | RED | 617228882 | GRN | 617228885 | |
| | | | YEL | 617228883 | BLA | 617228886 | |
| | | | BRN | 617228887 | | | |
| 1723 | Paper/Bottle Recycling Top for 1720 | 4 | GRAY | 617238881 | BLUE | 617238884 | 35 |
| | | | RED | 617238882 | GRN | 617238885 | |
| | | | YEL | 617238883 | BLA | 617238886 | |
| | | | BRN | 617238887 | | | |
| 1724 | Large Waste Recycling Top for 1720 | 4 | GRAY | 617248881 | BLUE | 617248884 | 35 |
| | | | RED | 617248882 | GRN | 617248885 | |
| | | | YEL | 617248883 | BLA | 617248886 | |
| | | | BRN | 617248887 | | | |
| 1725 | Enclosed Lid for 1720 | 4 | GRAY | 617258881 | BLUE | 617258884 | 35 |
| | | | RED | 617258882 | GRN | 617258885 | |
| | | | YEL | 617258883 | BLA | 617258886 | |
| | | | BRN | 617258887 | | | |
| 1730 | Top for 1215 | 4 | LGRAY | 617308881 | | | 33 |
| 1731 | Paper Recycling Top for 1730 | 4 | GRAY | 617318881 | BLUE | 617318884 | 33 |
| | | | RED | 617318882 | GRN | 617318885 | |
| | | | YEL | 617318883 | BLA | 617318886 | |
| | | | BRN | 617318887 | | | |
| 1732 | Bottle Recycling Top for 1730 | 4 | GRAY | 617328881 | BLUE | 617328884 | 33 |
| | | | RED | 617328882 | GRN | 617328885 | |
| | | | YEL | 617328883 | BLA | 617328886 | |
| | | | BRN | 617328887 | | | |

PRODUCT INDEX

| No. | Product Name | Pack | Color | Order Code | Color | Order Code | Page |
|------|---|------|-------|------------|-------|------------|--------------------|
| 1733 | Paper/Bottle Recycling Top for 1730 | 4 | GRAY | 617338881 | BLUE | 617338884 | 33 |
| | | | RED | 617338882 | GRN | 617338885 | |
| | | | YEL | 617338883 | BLA | 617338886 | |
| | | | BRN | 617338887 | | | |
| 1734 | Enclosed Lid for 1730 | 4 | GRAY | 617348881 | BLUE | 617348884 | 33 |
| | | | RED | 617348882 | GRN | 617348885 | |
| | | | YEL | 617348883 | BLA | 617348886 | |
| | | | BRN | 617348887 | | | |
| 1740 | Top for 1215 | 4 | LGRAY | 617408881 | | | 34 |
| 1741 | Paper Recycling Top for 1740 | 4 | GRAY | 617418881 | BLUE | 617418884 | 34 |
| | | | RED | 617418882 | GRN | 617418885 | |
| | | | YEL | 617418883 | BLA | 617418886 | |
| | | | BRN | 617418887 | | | |
| 1742 | Bottle Recycling Top for 1740 | 4 | GRAY | 617428881 | BLUE | 617428884 | 34 |
| | | | RED | 617428882 | GRN | 617428885 | |
| | | | YEL | 617428883 | BLA | 617428886 | |
| | | | BRN | 617428887 | | | |
| 1743 | Paper/Bottle Recycling Top for 1740 | 4 | GRAY | 617438881 | BLUE | 617438884 | 34 |
| | | | RED | 617438882 | GRN | 617438885 | |
| | | | YEL | 617438883 | BLA | 617438886 | |
| | | | BRN | 617438887 | | | |
| 1744 | Enclosed Lid for 1740 | 4 | GRAY | 617448881 | BLUE | 617448884 | 34 |
| | | | RED | 617448882 | GRN | 617448885 | |
| | | | YEL | 617448883 | BLA | 617448886 | |
| | | | BRN | 617448887 | | | |
| 1750 | Round Bins Lid for 1013 | 6 | LGRAY | 617508881 | | | 36 |
| 1751 | Paper Recycling Top for 1750 | 6 | GRAY | 617518881 | BLUE | 617518884 | 36 |
| | | | RED | 617518882 | GRN | 617518885 | |
| | | | YEL | 617518883 | BLA | 617518886 | |
| | | | BRN | 617518887 | | | |
| 1752 | Bottle and Can Recycling Top for 1750 | 6 | GRAY | 617528881 | BLUE | 617528884 | 36 |
| | | | RED | 617528882 | GRN | 617528885 | |
| | | | YEL | 617528883 | BLA | 617528886 | |
| | | | BRN | 617528887 | | | |
| 1753 | Paper/Bottle Recycling Top for 1750 | 6 | GRAY | 617538881 | BLUE | 617538884 | 36 |
| | | | RED | 617538882 | GRN | 617538885 | |
| | | | YEL | 617538883 | BLA | 617538886 | |
| | | | BRN | 617538887 | | | |
| 1754 | Large Waste Recycling Top for 1750 | 6 | GRAY | 617548881 | BLUE | 617548884 | 36 |
| | | | RED | 617548882 | GRN | 617548885 | |
| | | | YEL | 617548883 | BLA | 617548886 | |
| | | | BRN | 617548887 | | | |
| 1755 | Enclosed Lid for 1750 | 6 | GRAY | 617558881 | BLUE | 617558884 | 36 |
| | | | RED | 617558882 | GRN | 617558885 | |
| | | | YEL | 617558883 | BLA | 617558886 | |
| | | | BRN | 617558887 | | | |
| 1811 | Thor® Dolly for 1010/1012/1013/1014/1015 | 2 | BLA | 618118881 | | | 11, 29, 60, 61, 79 |
| 1812 | Thor® Square Dolly for 1231/1233 | 2 | BLA | 618128881 | | | 29, 61, 187, 267 |
| 1813 | Thor® Quiet Dolly for 1010/1012/1013/1014/1015 | 2 | BLA | 618138881 | | | 11, 29, 61 |
| 1814 | Svelte® Rectangular Dolly, for 1211/1212/1213/1214/1220/1221 | 2 | BLA | 618148881 | | | 20, 62, 63, 78 |
| 1815 | Svelte® Double-compartment Rectangular Dolly, for 1211/1212/1213/1214/1220/1221 | 1 | BLA | 618158881 | | | 20, 63 |
| 1816 | Svelte® Tri-compartment Rectangular Dolly, for 1211/1212/1213/1214/1220/1221 | 1 | BLA | 618168881 | | | 20, 63 |
| 1817 | Svelte® Four-compartment Rectangular Dolly, for 1211/1212/1213/1214/1220/1221 | 1 | BLA | 618178881 | | | 20, 63 |
| 1818 | Thor® Drum Dolly for 1010/1012/1013/1014/1015/1231/1233 | 1 | BLA | 618188881 | | | 11, 29, 61 |
| 1819 | Thor® Universal Dru Dolly | 2 | BLA | 618198881 | | | 11 |
| 1821 | Thor® Rim Caddy for 1014 | 1 | YEL | 618218881 | | | 60, 79 |
| 1822 | Signboard Hook | 6 | BLA | 618228881 | | | 61, 80 |
| 1823 | Carry Caddy | 4 | BLA | 618238881 | | | 61, 80 |
| 1824 | Svelte® Rim Caddy for 1211/1213/1220 | 1 | YEL | 618248881 | BLA | 618248882 | 62, 78 |

| No. | Product Name | Pack | Color | Order Code | Color | Order Code | Page |
|------|--|------|-------|------------|--------|------------|----------------|
| 1825 | Svelte® Dolly for 1211/1213/1220 | 2 | BLA | 618258881 | | | 62, 78 |
| 1826 | Svelte® Connector for 1825 | 1 | BLA | 618268881 | | | 62, 78 |
| 1827 | Svelte® Hook for 1824 | 4 | YEL | 618278881 | BLA | 618278882 | 62, 79 |
| 1828 | Svelte® Caddy Bag for 1213 | 2 | YEL | 618288881 | BLA | 618288882 | 62, 79 |
| 1831 | Thor® Caddy Bag for 1013/1014 | 6 | YEL | 618318881 | | | 60, 79 |
| 1839 | Label Kit for 1750 | 1 | | 618398881 | | | 36 |
| 1842 | Label Kit for 1700 | 1 | | 618428881 | | | 31 |
| 1843 | Label Kit for 1211/1213 | 1 | | 618438881 | | | 31, 33, 35, 36 |
| 1844 | Label Kit for 1710 | 1 | | 618448881 | | | 32 |
| 1845 | Label Kit for 1211/1213 | 1 | | 618458881 | | | 32 |
| 1846 | Label Kit for 1720 | 1 | | 618468881 | | | 35 |
| 1847 | Label Kit for 1730 | 1 | | 618478881 | | | 33 |
| 1848 | Label Kit for 1740 | 1 | | 618488881 | | | 34 |
| 1849 | Label Kit for 1215 | 1 | | 618498881 | | | 34 |
| 1851 | Label Kit for 1241 | 1 | | 618518881 | | | 38 |
| 1940 | “Recyclable Waste” Label | 10 | | 619408881 | | | 20, 63 |
| 1941 | “Soil” Label | 10 | | 619418881 | | | 20, 63 |
| 1942 | “Building Materials” Label | 10 | | 619428881 | | | 20, 63 |
| 1943 | “Garden Waste” Label | 10 | | 619438881 | | | 20, 63 |
| 1944 | “Food Waste” Label | 10 | | 619448881 | | | 20, 63 |
| 1945 | “Paint” Label | 10 | | 619458881 | | | 20, 63 |
| 1946 | “Household and Garden Chemicals” Label | 10 | | 619468881 | | | 20, 63 |
| 1947 | “Mixed paper and card” Label | 10 | | 619478881 | | | 20, 63 |
| 1948 | “Plastics” Label | 10 | | 619488881 | | | 20, 63 |
| 1949 | “Mixed Textiles and Clothes” Label | 10 | | 619498881 | | | 20, 63 |
| 1950 | “Mixed Glass” Label | 10 | | 619508881 | | | 20, 63 |
| 1951 | “Metal” Label | 10 | | 619518881 | | | 20, 63 |
| 1952 | “Batteries” Label | 10 | | 619528881 | | | 20, 63 |
| 2011 | Rockface® Container with an Ashtray Top, and 1281 Liner | 1 | BRN | 620118881 | LBRN | 620118882 | 43 |
| 2012 | Rockface® Container with a Funnel-top, and 1281 Liner | 1 | BRN | 620128881 | LBRN | 620128882 | 43 |
| 2021 | Rockface® Container with an Ashtray top, and 1282 Liner | 1 | BRN | 620218881 | BLA | 620218883 | 43 |
| | | | LBRN | 620218882 | | | |
| 2022 | Rockface® Container with a Funnel-top, and 1282 Liner | 1 | BRN | 620228881 | BLA | 620228883 | 43 |
| | | | LBRN | 620228882 | | | |
| 2023 | Rockface® Container with a Drum-type Top, and 1282 Liner | 1 | BRN | 620238881 | BLA | 620238883 | 43 |
| | | | LBRN | 620238882 | | | |
| 2024 | Rockface® Container with a Drum-type Ashtray Top, and 1282 Liner | 1 | BRN | 620248881 | BLA | 620248883 | 43 |
| | | | LBRN | 620248882 | | | |
| 2031 | Rockface® Container with a Drum-type Top, and 1283 Liner | 1 | BRN | 620318881 | BLA | 620318883 | 43 |
| | | | LBRN | 620318882 | | | |
| 2032 | Rockface® Container with a Drum-type Ashtray Top, and 1283 Liner | 1 | BRN | 620328881 | BLA | 620328883 | 43 |
| | | | LBRN | 620328882 | | | |
| 2041 | Rockface® Concrete Faceplate, for 2011/2012 | 4 | CORL | 620418881 | ROCK | 620418882 | 43 |
| 2042 | Rockface® Concrete Faceplate, for 2021/2022/2023/2024 | 4 | CORL | 620428881 | BSTONE | 620428883 | 43 |
| | | | ROCK | 620428882 | | | |
| 2043 | Rockface® Concrete Faceplate, for 2031/2032 | 4 | CORL | 620438881 | BSTONE | 620438883 | 43 |
| | | | ROCK | 620438882 | | | |
| 2044 | Rockface® Ad Backing Faceplate, for 2031/2032 | 4 | CLR | 620448881 | | | 43 |
| 2051 | Rockface® Container with a Drum-type Ashtray Top | 1 | BRN | 620518881 | EGRN | 620518883 | 44 |
| | | | GRAY | 620518882 | | | |
| 2052 | Rockface® Container with a Drum-type Top | 1 | BRN | 620528881 | EGRN | 620528883 | 44 |
| | | | GRAY | 620528882 | | | |
| 2061 | Rockface® Container with a Drum-type Ashtray Top | 1 | BRN | 620618881 | EGRN | 620618883 | 44 |
| | | | GRAY | 620618882 | | | |
| 2062 | Rockface® Container with a Drum-type Top | 1 | BRN | 620628881 | EGRN | 620628883 | 44 |
| | | | GRAY | 620628882 | | | |
| 2071 | Rockface® Container with a Drum-type Ashtray Top, Rod Openings | 1 | BRN | 620718881 | EGRN | 620718883 | 44 |
| | | | GRAY | 620718882 | | | |
| 2072 | Rockface® Container with a Drum-type Top, Rod Openings | 1 | BRN | 620728881 | EGRN | 620728883 | 44 |
| | | | GRAY | 620728882 | | | |

PRODUCT INDEX

| No. | Product Name | Pack | Color | Order Code | Color | Order Code | Page |
|------|---|------|-------------|------------------------|-------------|------------------------|--------|
| 2081 | Rockface® Container with a Drum-type Ashtray Top | 1 | BRN GRAY | 620818881 620818882 | EGRN | 620818883 | 44 |
| 2082 | Rockface® Container with a Drum-type Top | 1 | BRN GRAY | 620828881 620828882 | EGRN | 620828883 | 44 |
| 2083 | Rockface® Container with a Flat-type Top | 1 | BRN GRAY | 620838881 620838882 | EGRN | 620838883 | 44 |
| 2091 | Rockface® Container with a Drum-type Top | 1 | BRN GRAY | 620918881 620918882 | EGRN | 620918883 | 44 |
| 2092 | Rockface® Container with a Drum-type Top with Side Door | 1 | BRN GRAY | 620928881 620928882 | EGRN | 620928883 | 44 |
| 2093 | Rockface® Container with a Flat-type Top | 1 | BRN GRAY | 620938881 620938882 | EGRN | 620938883 | 44 |
| 2101 | Riston® Decorative Container | 1 | BLA BEIG | 621018881 621018882 | GRN | 621018883 | 52 |
| 2102 | Riston® Decorative Container with Ashtray Top | 1 | BLA BEIG | 621028881 621028882 | GRN | 621028883 | 52 |
| 2103 | Riston® Decorative Container with Tray Top | 1 | BLA | 621038881 | BEIG | 621038882 | 52 |
| 2104 | Riston® Paper Recycling Container | 1 | BLUE | 621048881 | GRN | 621048882 | 38 |
| 2105 | Riston® Bottle Recycling Container | 1 | BLUE | 621058881 | GRN | 621058882 | 38 |
| 2106 | Riston® Decorative Container | 1 | BLA BEIG | 621068881 621068882 | GRN | 621068883 | 52 |
| 2107 | Riston® Decorative Container with Ashtray Top | 1 | BLA BEIG | 621078881 621078882 | GRN | 621078883 | 52 |
| 2111 | Beaucan® Outdoor Decorative Trash Can, Two Sides of Movable Doors | 1 | BLA | 621118881 | BEIG | 621118882 | 52 |
| 2112 | Beaucan® Outdoor Decorative Trash Can, Four-sided Openings | 1 | BLA | 621128881 | BEIG | 621128882 | 52 |
| 2113 | Beaucan® Outdoor Decorative Trash Can, Two Sides of Movable Doors | 1 | BLA BRN | 621138881 621138883 | BEIG | 621138882 | 52 |
| 2200 | Neatace® Trash Can, Dome Cover | 1 | BLA | 622008881 | BEIG | 622008882 | 51 |
| 2201 | Neatace® Trash Can, Ashtray Top Cover with Valves | 1 | BLA | 622018881 | BEIG | 622018882 | 51 |
| 2202 | Neatace® Trash Can, Ashtray Top Cover without Valves | 1 | BLA | 622028881 | BEIG | 622028882 | 51 |
| 2203 | Neatace® Trash Can, Open Top Cover | 1 | BLA | 622038881 | BEIG | 622038882 | 51 |
| 2204 | Neatace® Trash Can, Spherical Top Cover | 1 | BLA | 622048881 | BEIG | 622048882 | 51 |
| 2205 | Neatace® Trash Can, Spherical Top Cover, Top Open | 1 | BLA | 622058881 | BEIG | 622058882 | 51 |
| 2206 | Neatace® Trash Can, Dome Cover | 1 | BLA | 622068881 | BEIG | 622068882 | 51 |
| 2207 | Neatace® Trash Can, Ashtray Top Cover with Valves | 1 | BLA | 622078881 | BEIG | 622078882 | 51 |
| 2208 | Neatace® Trash Can, Ashtray Top Cover without Valves | 1 | BLA | 622088881 | BEIG | 622088882 | 51 |
| 2209 | Neatace® Trash Can, Open Top Cover | 1 | BLA | 622098881 | BEIG | 622098882 | 51 |
| 2210 | Neatace® Trash Can, Spherical Top Cover | 1 | BLA | 622108881 | BEIG | 622108882 | 51 |
| 2211 | Wall-mounted Cigarette Butts Bucket | 1 | MSILV | 622118881 | | | 55 |
| 2212 | Wall-mounted Cigarette Butts Bucket | 1 | TITA | 622128881 | | | 56 |
| 2213 | Neatace® Trash Can, Spherical Top Cover, Top Open | 1 | BLA | 622138881 | BEIG | 622138882 | 51 |
| 2221 | Wall-mounted Cigarette Butts Bucket | 1 | MSILV | 622218881 | | | 55 |
| 2231 | Floor-standing Cigarette Butts Bucket | 1 | MSILV | 622318881 | | | 56 |
| 2241 | Floor-standing Cigarette Butts Bucket | 1 | MSILV | 622418881 | | | 56 |
| 2242 | Wall-mounted Cigarette Butts Bucket | 1 | TITA | 622428881 | | | 56 |
| 2251 | Large-capacity Cigarette Butts Bucket | 1 | MSILV | 622518881 | | | 57 |
| 2261 | Floor-standing Cigarette Butt Bucket | 1 | MSILV | 622618881 | | | 55 |
| 2262 | Floor-standing Cigarette Butt Bucket | 1 | MSILV | 622628881 | | | 57 |
| 2271 | Floor-standing Cigarette Butt Bucket | 1 | MSILV | 622718881 | | | 55 |
| 2281 | Floor-standing Cigarette Butt Bucket | 1 | MSILV | 622818881 | | | 55 |
| 2291 | Floor-standing Cigarette Butt Bucket | 1 | MSILV | 622918881 | | | 55 |
| 2300 | Cigarette Barrel, Mirror Chrome | 1 | SS | 623008881 | | | 58 |
| 2301 | Cigarette Barrel, Satin Stainless Steel | 1 | SSS | 623018881 | | | 58 |
| 2302 | Cigarette Barrel, Titanium Surface | 1 | TITA | 623028881 | | | 58 |
| 2303 | Cigarette Barrel, Spray Surface | 1 | BLUE GRN | 623038881 623038882 | GRAY RED | 623038883 623038884 | 58 |
| 2304 | Cigarette Barrel, Mirror Foot Circle | 1 | GRAY | 623048881 | BLA | 623048882 | 58 |
| 2305 | Cigarette Barrel, Titanium Foot Circle | 1 | CR | 623058881 | EGRN | 623058882 | 58 |
| 2310 | Ashtray/Trash, Mirror Chrome | 1 | SS | 623108881 | | | 45, 58 |
| 2311 | Ashtray/Trash, Satin Stainless Steel | 1 | SSS | 623118881 | | | 45, 58 |
| 2312 | Ashtray/Trash, Titanium Surface | 1 | TITA | 623128881 | | | 45, 58 |
| 2313 | Ashtray/Trash, Spray Surface | 1 | BLUE GRN | 623138881 623138882 | GRAY RED | 623138883 623138884 | 47, 58 |

| No. | Product Name | Pack | Color | Order Code | Color | Order Code | Page |
|------|---|------|-------|------------|-------|------------|----------|
| 2314 | Ashtray/Trash, Mirror Foot Circle | 1 | GRAY | 623148881 | BLA | 623148882 | 46, 58 |
| 2315 | Ashtray/Trash, Titanium Foot Circle | 1 | CR | 623158881 | EGRN | 623158882 | 46, 58 |
| 2320 | Container Open-top, Mirror Chrome | 1 | SS | 623208881 | | | 45 |
| 2321 | Container Open-top, Satin Stainless Steel | 1 | SSS | 623218881 | | | 45 |
| 2322 | Container Open-top, Titanium Surface | 1 | TITA | 623228881 | | | 45 |
| 2323 | Container Open-top, Spray Surface | 1 | BLUE | 623238881 | GRAY | 623238883 | 47 |
| | | | GRN | 623238882 | RED | 623238884 | |
| 2324 | Container Open-top, Mirror Foot Circle | 1 | GRAY | 623248881 | BLA | 623248882 | 46 |
| 2325 | Container Open-top, Titanium Foot Circle | 1 | CR | 623258881 | EGRN | 623258882 | 46 |
| 2330 | Ashtray/Trash, Mirror Chrome | 1 | SS | 623308881 | | | 45, 58 |
| 2331 | Ashtray/Trash, Satin Stainless Steel | 1 | SSS | 623318881 | | | 45, 58 |
| 2332 | Ashtray/Trash, Titanium Surface | 1 | TITA | 623328881 | | | 45, 58 |
| 2333 | Ashtray/Trash, Spray Surface | 1 | BLUE | 623338881 | GRAY | 623338883 | 47, 58 |
| | | | GRN | 623338882 | RED | 623338884 | |
| 2334 | Ashtray/Trash, Mirror Foot Circle | 1 | GRAY | 623348881 | BLA | 623348882 | 46, 58 |
| 2335 | Ashtray/Trash, Titanium Foot Circle | 1 | CR | 623358881 | EGRN | 623358882 | 46, 58 |
| 2340 | Container Flat-top, Mirror Chrome | 1 | SS | 623408881 | | | 45 |
| 2341 | Container Flat-top, Satin Stainless Steel | 1 | SSS | 623418881 | | | 45 |
| 2342 | Container Flat-top, Titanium Surface | 1 | TITA | 623428881 | | | 45 |
| 2343 | Container Flat-top, Spray Surface | 1 | BLUE | 623438881 | GRAY | 623438883 | 47 |
| | | | GRN | 623438882 | RED | 623438884 | |
| 2344 | Container Flat-top, Mirror Foot Circle | 1 | GRAY | 623448881 | BLA | 623448882 | 46 |
| 2345 | Container Flat-top, Titanium Foot Circle | 1 | CR | 623458881 | EGRN | 623458882 | 46 |
| 2350 | Container Round-top, Mirror Chrome | 1 | SS | 623508881 | | | 45 |
| 2351 | Container Round-top, Satin Stainless Steel | 1 | SSS | 623518881 | | | 45 |
| 2352 | Container Round-top, Titanium Surface | 1 | TITA | 623528881 | | | 45 |
| 2353 | Container Round-top, Spray Surface | 1 | BLUE | 623538881 | GRAY | 623538883 | 47 |
| | | | GRN | 623538882 | RED | 623538884 | |
| 2354 | Container Round-top, Mirror Foot Circle | 1 | GRAY | 623548881 | BLA | 623548882 | 46 |
| 2355 | Container Round-top, Titanium Foot Circle | 1 | CR | 623558881 | EGRN | 623558882 | 46 |
| 2360 | Container Round-top, Mirror Chrome | 1 | SS | 623608881 | | | 45 |
| 2361 | Container Round-top, Satin Stainless Steel | 1 | SSS | 623618881 | | | 45 |
| 2362 | Container Round-top, Titanium Surface | 1 | TITA | 623628881 | | | 45 |
| 2363 | Container Round-top, Spray Surface | 1 | BLUE | 623638881 | GRAY | 623638883 | 47 |
| | | | GRN | 623638882 | RED | 623638884 | |
| 2364 | Container Round-top, Mirror Foot Circle | 1 | GRAY | 623648881 | BLA | 623648882 | 46 |
| 2365 | Container Round-top, Titanium Foot Circle | 1 | CR | 623658881 | EGRN | 623658882 | 46 |
| 2370 | Container Open-top, Mirror Chrome | 1 | SS | 623708881 | | | 45 |
| 2371 | Steeledge Container Open-top, Satin Stainless Steel | 1 | SSS | 623718881 | | | 45 |
| 2372 | Steeledge Container Open-top, Titanium Surface | 1 | TITA | 623728881 | | | 45 |
| 2373 | Steeledge Container Open-top, Spray Surface | 1 | BLUE | 623738881 | GRAY | 623738883 | 47 |
| | | | GRN | 623738882 | RED | 623738884 | |
| 2374 | Steeledge Container Open-top, Mirror Foot Circle | 1 | GRAY | 623748881 | BLA | 623748882 | 46 |
| 2375 | Steeledge Container Open-top, Titanium Foot Circle | 1 | CR | 623758881 | EGRN | 623758882 | 46 |
| 2391 | Aluminum Trash Can | 1 | MSILV | 623918881 | | | 47 |
| 2392 | Aluminum Trash Can | 1 | MSILV | 623928881 | | | 47 |
| 2393 | Aluminum Trash Can | 1 | MSILV | 623938881 | | | 47 |
| 2401 | Stainless Trash Can | 1 | MSILV | 624018881 | | | 27 |
| 2402 | Stainless Trash Can | 1 | MSILV | 624028881 | | | 27 |
| 2403 | Stainless Trash Can | 1 | MSILV | 624038881 | | | 27 |
| 3011 | Food Storage Box with Lid | 6 | GRAY | 630118881 | BLUE | 630118885 | 171, 186 |
| | | | WHT | 630118882 | GRN | 630118886 | |
| | | | RED | 630118883 | CLR | 630118887 | |
| | | | YEL | 630118884 | | | |
| 3012 | Food Storage Box with Lid | 6 | GRAY | 630128881 | BLUE | 630128885 | 171, 186 |
| | | | WHT | 630128882 | GRN | 630128886 | |
| | | | RED | 630128883 | CLR | 630128887 | |
| | | | YEL | 630128884 | | | |
| 3013 | Medical Waste Recycle Case | 6 | YEL | 630138881 | | | 41 |
| 3014 | Medical Waste Recycle Case | 6 | YEL | 630148881 | | | 41 |
| 3021 | Stackable Tote Bin | 6 | GRAY | 630218881 | YEL | 630218884 | 172, 186 |
| | | | WHT | 630218882 | BLUE | 630218885 | |
| | | | RED | 630218883 | GRN | 630218886 | |

PRODUCT INDEX

| No. | Product Name | Pack | Color | Order Code | Color | Order Code | Page |
|------|--|------|-------|------------|-------|------------|----------|
| 3022 | Stackable Tote Bin | 6 | GRAY | 630228881 | YEL | 630228884 | 172, 186 |
| | | | WHT | 630228882 | BLUE | 630228885 | |
| | | | RED | 630228883 | GRN | 630228886 | |
| 3023 | Lid for 3021/3022 | 6 | GRAY | 630238881 | YEL | 630238884 | 172, 186 |
| | | | WHT | 630238882 | BLUE | 630238885 | |
| | | | RED | 630238883 | GRN | 630238886 | |
| 3511 | Bitbar® Tool Box | 1 | BLA | 635118881 | | | 171 |
| 3512 | Bitbar® Tool Box With Cushion | 1 | BLA | 635128881 | | | 171 |
| 3513 | Caster Kit | 1 | | 635138881 | | | 171 |
| 3514 | Multi-purpose Tool Box | 1 | BLA | 635148881 | | | 171 |
| 3711 | Shelving, 4-shelf Unit | 1 | BLA | 637118881 | | | 170 |
| 3712 | Shelving, 5-shelf Unit | 1 | BLA | 637128881 | | | 170 |
| 3713 | Shelving, 4-shelf Unit | 1 | BLA | 637138881 | | | 170 |
| 3714 | Shelving, 5-shelf Unit | 1 | BLA | 637148881 | | | 170 |
| 3715 | Shelving, 6-shelf Unit | 1 | BLA | 637158881 | | | 170 |
| 3716 | Mobile Shelf Truck, 5-shelf Unit | 1 | BLA | 637168881 | | | 170 |
| 3717 | Mobile Shelf Truck, 4-shelf Unit | 1 | BLA | 637178881 | | | 170 |
| 3718 | Lockable Doors for 3711/3712/3715/3716 | 1 | BLA | 637188881 | | | 170 |
| 3719 | Enclosed Panels for 3711/3712/3715/3716 | 1 | BLA | 637198881 | | | 170 |
| 4010 | Hi5® Utility Cart, 2-shelf Unit | 1 | BLA | 640108881 | OWHT | 640108883 | 164, 232 |
| | | | PLAT | 640108882 | GRAY | 640108884 | |
| 4011 | Hi5® Utility Cart, Open Sided | 1 | BLA | 640118881 | OWHT | 640118883 | 164, 232 |
| | | | PLAT | 640118882 | GRAY | 640118884 | |
| 4012 | Hi5® Utility Cart with Enclosed End Panels on 2 Sides | 1 | BLA | 640128881 | PLAT | 640128882 | 164 |
| 4013 | Hi5® Utility Cart with Lockable Doors, Sliding Drawer | 1 | BLA | 640138881 | | | 164 |
| 4020 | Hi5® Utility Cart, 2-shelf Unit | 1 | BLA | 640208881 | | | 165 |
| 4021 | Hi5® Utility Cart, Open Sided | 1 | OWHT | 640218881 | GRAY | 640218883 | 165, 232 |
| | | | BLA | 640218882 | | | |
| 4022 | Hi5® Utility Cart with Enclosed End Panels on 2 Sides | 1 | OWHT | 640228881 | BLA | 640228882 | 165 |
| 4023 | Hi5® Utility Cart with Enclosed End Panels on 3 Sides | 1 | OWHT | 640238881 | BLA | 640238882 | 165, 232 |
| 4024 | Hi5® Utility Cart with Lockable Doors, Sliding Drawer | 1 | GRAY | 640248881 | | | 165 |
| 4025 | Hi5® Equipment Cart | 1 | BLA | 640258881 | | | 165 |
| 4026 | Hi5® 4 Shelf Cart | 1 | BLA | 640268881 | | | 165 |
| 4027 | Hi5® Utility Cart with two sets of Lockable Doors | 1 | BLA | 640278881 | | | 165 |
| 4031 | Bitbar® Mobile Work Center with 4-drawer and Cabinet | 1 | BLA | 640318881 | | | 146 |
| 4032 | Bitbar® Mobile Work Center with 2-door Cabiner | 1 | BLA | 640328881 | | | 146 |
| 4033 | Bitbar® Mobile Work Center with 8-drawer | 1 | BLA | 640338881 | | | 146 |
| 4041 | Bitbar® 2-shelf Utility Cart | 1 | BLA | 640418881 | BEIG | 640418882 | 147, 236 |
| 4042 | Bitbar® Utility Cart with Drawer | 1 | BLA | 640428881 | BEIG | 640428882 | 147 |
| 4043 | Bitbar® 3-shelf Utility Cart | 1 | BLA | 640438881 | BEIG | 640438882 | 147 |
| 4044 | Bitbar® 2-shelf Utility Cart | 1 | BLA | 640448881 | BEIG | 640448882 | 147, 236 |
| 4045 | Bitbar® 2-shelf Utility Cart Flat Shelf | 1 | BLA | 640458881 | BEIG | 640458882 | 147, 236 |
| 4046 | Bitbar® 3-shelf Utility Cart | 1 | BLA | 640468881 | BEIG | 640468882 | 147 |
| 4047 | Bitbar® 3-shelf Utility Cart Flat Shelf | 1 | BLA | 640478881 | BEIG | 640478882 | 147 |
| 4051 | Ladder Cart | 1 | BLA | 640518881 | | | 148 |
| 4061 | Material Supply Cart | 1 | BLA | 640618881 | | | 149 |
| 4062 | Material Supply Cart | 1 | BLA | 640628881 | | | 149 |
| 4063 | Shelf for 4061 | 1 | BLA | 640638881 | | | 149 |
| 4064 | Shelf for 4062 | 1 | BLA | 640648881 | | | 149 |
| 4065 | Carton Recovery System | 1 | YEL | 640658881 | | | 149 |
| 4071 | Hi5® Foldable Service Cart | 1 | BLA | 640718881 | BRN | 640718883 | 166, 233 |
| | | | GRAY | 640718882 | | | |
| 4072 | Hi5® Foldable Service Cart | 1 | BLA | 640728881 | BRN | 640728883 | 166, 233 |
| | | | GRAY | 640728882 | | | |
| 4081 | Hi5® Utility Cart | 1 | BLA | 640818881 | | | 167, 234 |
| 4082 | Hi5® Utility Cart with Enclosed End Panels on 3 Sides | 1 | BLA | 640828881 | | | 167, 234 |
| 4083 | Hi5® Utility Cart with Lockable Doors, Sliding Drawer | 1 | BLA | 640838881 | | | 167, 234 |
| 4084 | Hi5® Utility Cart with Lockable Doors, Enclosed Panels | 1 | BLA | 640848881 | | | 167, 234 |
| 4085 | Enclosed Panels | 1 | BLA | 640858881 | | | 167, 235 |
| 4086 | Lockable Doors | 1 | BLA | 640868881 | | | 167, 235 |
| 4087 | Trim Panel | 1 | BLA | 640878881 | | | 167, 235 |
| 4411 | Oeasy® Platform Truck | 1 | BLA | 644118881 | | | 152, 232 |
| 4412 | Oeasy® Platform Truck | 1 | BLA | 644128881 | | | 152 |
| 4413 | Oeasy® Platform Truck | 1 | BLA | 644138881 | | | 152, 232 |

| No. | Product Name | Pack | Color | Order Code | Color | Order Code | Page |
|------|--|------|-------|------------|-------|------------|---------------|
| 4414 | Oeasys® Platform Truck | 1 | BLA | 644148881 | | | 152 |
| 4415 | Oeasys® Platform Truck | 1 | BLA | 644158881 | | | 152 |
| 4416 | Oeasys® Platform Truck | 1 | BLA | 644168881 | | | 152 |
| 4417 | Oeasys® Platform Truck | 1 | BLA | 644178881 | | | 152 |
| 4418 | Oeasys® Platform Truck | 1 | BLA | 644188881 | | | 152 |
| 4421 | Oeasys® Plate Truck | 1 | BLA | 644218881 | | | 153 |
| 4422 | Oeasys® Plate Truck | 1 | BLA | 644228881 | | | 153 |
| 4423 | Oeasys® Plate Truck | 1 | BLA | 644238881 | | | 153 |
| 4431 | Oeasys® Plate Truck | 1 | BLA | 644318881 | | | 153 |
| 4432 | Oeasys® Plate Truck | 1 | BLA | 644328881 | | | 153 |
| 4433 | Oeasys® Plate Truck | 1 | BLA | 644338881 | | | 153 |
| 4441 | Oeasys® Mobile Work Station | 1 | BLA | 644418881 | | | 154 |
| 4442 | Oeasys® Mobile Work Station | 1 | BLA | 644428881 | | | 154 |
| 4443 | Oeasys® Mobile Work Station | 1 | BLA | 644438881 | | | 154 |
| 4451 | Oeasys® Pipe Truck | 1 | BLA | 644518881 | | | 155 |
| 4452 | Oeasys® Pipe Truck | 1 | BLA | 644528881 | | | 155 |
| 4453 | Oeasys® Pipe Truck | 1 | BLA | 644538881 | | | 155 |
| 4461 | Oeasys® Platform Cart with Fence | 1 | BLA | 644618881 | | | 156 |
| 4462 | Oeasys® Platform Cart with Fence | 1 | BLA | 644628881 | | | 156 |
| 4463 | Oeasys® Platform Cart with Fence | 1 | BLA | 644638881 | | | 156 |
| 4464 | Oeasys® Platform Cart with Fence | 1 | BLA | 644648881 | | | 156 |
| 4465 | Oeasys® Platform Cart with Fence | 1 | BLA | 644658881 | | | 156 |
| 4471 | Oeasys® Semi-movable Traction Platform Truck | 1 | BLA | 644718881 | | | 155 |
| 4472 | Oeasys® Semi-movable Traction Platform Truck | 1 | BLA | 644728881 | | | 155 |
| 4473 | Oeasys® Semi-movable Traction Platform Truck | 1 | BLA | 644738881 | | | 155 |
| 4474 | Oeasys® Semi-movable Traction Jack Handle | 1 | BLA | 644748881 | | | 155 |
| 4481 | Utility Trolley, Utility Duty with 7.5cm Casters | 1 | BLA | 644818881 | | | 156, 238 |
| 4482 | Utility Trolley, Standard Duty with 12.5cm Casters | 1 | BLA | 644828881 | | | 156, 238 |
| 4483 | Trolley | 1 | BLA | 644838881 | | | 157, 171, 186 |
| 4484 | Cup Rack's Cart | 1 | PLAT | 644848881 | GRAY | 644848882 | 238, 251 |
| 4485 | Cup Rack's Cart with Handle | 1 | PLAT | 644858881 | GRAY | 644858882 | 238, 251 |
| 4491 | Goods Shelves | 1 | BLA | 644918881 | | | 175, 185 |
| 4492 | Goods Shelves | 1 | BLA | 644928881 | | | 175, 185 |
| 4493 | Goods Shelves | 1 | BLA | 644938881 | | | 175, 185 |
| 4501 | Storage Pallet, for 2 Drums | 1 | BLA | 645018881 | | | 175 |
| 4502 | Storage Pallet, for 4 Drums | 1 | BLA | 645028881 | | | 175 |
| 4503 | Slope, Used With 4501/4502 | 2 | BLA | 645038881 | | | 175 |
| 4512 | Tilt Truck | 1 | BLA | 645128881 | | | 160 |
| 4513 | Cover for 4512/4522/4532/4542 | 1 | BLA | 645138881 | | | 162 |
| 4522 | Tilt Truck, Utility Duty | 1 | BLA | 645228881 | | | 160 |
| 4523 | Tilt Truck, Standard Duty | 1 | BLUE | 645238881 | | | 37 |
| 4532 | Heavy-Duty Towable Tilt Truck | 1 | BLA | 645328881 | | | 160 |
| 4542 | Heavy-Duty Forkliftable Tilt Truck | 1 | BLA | 645428881 | | | 161 |
| 4611 | Tilt Truck, Utility Duty | 1 | BLA | 646118881 | | | 161 |
| 4612 | Tilt Truck, Standard Duty | 1 | BLA | 646128881 | | | 161 |
| 4613 | Tilt Truck, Utility Duty | 1 | BLA | 646138881 | | | 161 |
| 4614 | Tilt Truck, Standard Duty | 1 | BLA | 646148881 | | | 161 |
| 4615 | Cover for 4611/4612 | 1 | BLA | 646158881 | | | 162 |
| 4616 | Cover for 4613/4614 | 1 | BLA | 646168881 | | | 162 |
| 4710 | 0.2m³ Cube Truck | 2 | BLA | 647108881 | WHT | 647108882 | 158, 187 |
| 4711 | 0.3m³ Cube Truck | 2 | BLA | 647118881 | YEL | 647118884 | 158, 187 |
| | | | WHT | 647118882 | RED | 647118885 | |
| | | | GRN | 647118883 | | | |
| 4712 | Heavy-Duty Utility Truck | 2 | BLA | 647128881 | | | 158 |
| 4713 | Lid for 4711/4712 | 1 | BLA | 647138881 | | | 158 |
| 4714 | 0.4m³ Cube Truck | 2 | BLA | 647148881 | WHT | 647148882 | 158, 187 |
| 4715 | 0.5m³ Cube Truck | 2 | BLA | 647158881 | WHT | 647158882 | 158, 187 |
| 4724 | 0.4m³ Cube Truck | 2 | BLUE | 647248881 | | | 37 |
| 4725 | 0.5m³ Cube Truck | 2 | BLUE | 647258881 | | | 37 |
| 4811 | 15 L Utility Bin | 2 | BLA | 648118881 | | | 167, 168, 235 |
| 4821 | 30 L Utility Bin | 2 | BLA | 648218881 | | | 167, 168, 235 |
| 4830 | Hook Kit (Set of 4) | 1 | BLA | 648308881 | | | 168 |

PRODUCT INDEX

| No. | Product Name | Pack | Color | Order Code | Color | Order Code | Page |
|------|--|------|-------|------------|-------|------------|-------------------|
| 4831 | 20cm Pneumatic Caster Kit | 1 | | 648318881 | | | 168 |
| 4832 | Ultra Silent Caster Kit (Set of 4) | 1 | GRAY | 648328881 | | | 168 |
| 4841 | Single Full Extension Drawer | 1 | RED | 648418881 | | | 168 |
| 4850 | Utility Sliding Drawer | 1 | BLA | 648508881 | | | 168 |
| 4851 | Utility Sliding Drawer | 1 | BLA | 648518881 | BRN | 648518882 | 73, 167, 168, 235 |
| 5010 | Clip for Handle | 6 | BLA | 650108881 | PLAT | 650108882 | 77 |
| 5011 | Grandmaid® Cleaning Cart | 1 | BLA | 650118881 | PLAT | 650118882 | 76 |
| 5012 | Trash Bags Cover, for 5011 | 2 | BLA | 650128881 | PLAT | 650128882 | 77 |
| 5013 | Spray bottle stack | 2 | BLA | 650138881 | | | 77 |
| 5014 | Storage Cabinet | 1 | BLA | 650148881 | PLAT | 650148882 | 77 |
| 5015 | Lockable Top Cover, for 5011 | 1 | BLA | 650158881 | PLAT | 650158882 | 77 |
| 5016 | Garbage Classification Fixed Frame | 1 | BLA | 650168881 | | | 77 |
| 5017 | Cleaning Tool Bracket | 6 | BLA | 650178881 | | | 77 |
| 5018 | Small Garbage Bag | 6 | BLUE | 650188881 | | | 77 |
| 5019 | Locking Door Kit for 5011 | 1 | YEL | 650198881 | BLA | 650198882 | 77 |
| 5021 | Grandmaid® Housekeeping Cart | 1 | BLA | 650218881 | PLAT | 650218882 | 68 |
| 5022 | Grandmaid® Housekeeping Cart with Doors | 1 | BLA | 650228881 | | | 68 |
| 5023 | Cart with Doors, Protective Security Hood | 1 | BLA | 650238881 | | | 68 |
| 5024 | Adjustable Shelf Kit for 5021/5022/5023/5031 | 1 | BLA | 650248881 | PLAT | 650248882 | 69 |
| 5025 | Under Deck Shelf Kit for 5021/5022/5023/5031 | 1 | BLA | 650258881 | PLAT | 650258882 | 71 |
| 5026 | Locking Door Kit for 5021/5022/5023 | 1 | BLA | 650268881 | BRN | 650268882 | 69 |
| 5027 | Protective Security Hood for 5021/5022/5023/5031 | 1 | BLA | 650278881 | PLAT | 650278882 | 69 |
| 5028 | Cover, Work in Couple with 6968/6974/6977 | 2 | BLA | 650288881 | PLAT | 650288882 | 69 |
| 5029 | Amenity Organizer | 6 | BLA | 650298881 | | | 69 |
| 5030 | Amenity Organizer | 6 | BLA | 650308881 | | | 69 |
| 5031 | Grandmaid® Compact Housekeeping Cart | 1 | BLA | 650318881 | PLAT | 650318882 | 70 |
| 5033 | Storage Accessory for 5031 | 1 | BLA | 650338881 | PLAT | 650338882 | 71 |
| 5035 | Locking Door Kit for 5031 | 1 | BLA | 650358881 | BRN | 650358882 | 71 |
| 5036 | Cleaning Tool Stack for 5031 | 2 | BLA | 650368881 | | | 71, 73 |
| 5037 | Hook Kit (Set of 4, RED, YEL, BLUE, GRN) for 5031/5051 | 1 | | 650378881 | | | 71, 73 |
| 5038 | Tops work with 1213 | 2 | BLA | 650388881 | PLAT | 650388881 | 71 |
| 5039 | Protective Security Hood for 5021/5022/5023/5031 | 1 | BLA | 650398881 | | | 69 |
| 5041 | X Type Linen Cart | 1 | GRAY | 650418881 | | | 82 |
| 5042 | X Type Linen Cart | 1 | GRAY | 650428881 | | | 82 |
| 5043 | Cloth/Straw Bag, for 5041 | 2 | BRN | 650438881 | | | 82 |
| 5044 | Cloth/Straw Bag, for 5042 | 2 | BRN | 650448881 | | | 82 |
| 5045 | Classification Linen Cart | 1 | GRAY | 650458881 | | | 81 |
| 5046 | Classification Linen Cart | 1 | GRAY | 650468881 | | | 81 |
| 5047 | Cloth/Straw Bag, for 5045 | 2 | BLA | 650478881 | | | 81 |
| 5048 | Cloth/Straw Bag, for 5046 | 2 | BLA | 650488881 | | | 81 |
| 5051 | Grandmaid® Cruise Housekeeping Cart | 1 | BLA | 650518881 | PLAT | 650518882 | 70 |
| 5052 | Locking Door Kit for 5051 | 1 | BLA | 650528881 | BRN | 650528882 | 71 |
| 5053 | Under Deck Shelf Kit for 5051 | 1 | BLA | 650538881 | PLAT | 650538882 | 71 |
| 5054 | Vinyl Bag for 5051 | 2 | BRN | 650548881 | | | 71 |
| 5055 | Tops work with 1215 | 2 | BLA | 650558881 | | | 71 |
| 5056 | Garbage Classification Fixed Frame (½ Separated), for 5021/5022/5023/5031 | 1 | BLA | 650568881 | | | 69 |
| 5057 | Garbage Classification Fixed Frame (and Separated), for 5021/5022/5023/5031 | 1 | BLA | 650578881 | | | 69 |
| 5061 | Pinnacle® Intelligent Housekeeping Cart | 1 | BLA | 650618881 | | | 72 |
| 5062 | Pinnacle® Intelligent Housekeeping Cart | 1 | BLA | 650628881 | | | 72 |
| 5063 | Pinnacle® Intelligent Housekeeping Cart | 1 | BLA | 650638881 | | | 72 |
| 5064 | Pinnacle® Intelligent Housekeeping Cart | 1 | BLA | 650648881 | | | 72 |
| 5065 | Adjustable Shelf Kit | 1 | BLA | 650658881 | | | 73 |
| 5066 | Locking Door Kit for 5061 / 5063 / 5071 / 5073 | 1 | BLA | 650668881 | | | 73 |
| 5067 | Safety Shield | 1 | BLA | 650678881 | PLAT | 650678882 | 69, 73 |
| 5068 | Vinyl Bag for 5061 / 5063 / 5071 / 5073 | 6 | BLA | 650688881 | | | 73 |
| 5069 | Vinyl Bag for 5062 / 5064 / 5072 / 5074 | 6 | BLA | 650698881 | | | 73 |
| 5070 | Locking Door Kit for 5062 / 5064 / 5072 / 5074 | 1 | BLA | 650708881 | | | 73 |
| 5071 | Pinnacle® Intelligent Housekeeping Cart with Built-In Divider | 1 | BLA | 650718881 | | | 72 |
| 5072 | Pinnacle® Intelligent Housekeeping Cart with Built-In Divider | 1 | BLA | 650728881 | | | 72 |

| No. | Product Name | Pack | Color | Order Code | Color | Order Code | Page |
|------|---|------|-------|------------|-------|------------|------------|
| 5073 | Pinnacle® Intelligent Housekeeping Cart with Built-In Divider | 1 | BLA | 650738881 | | | 72 |
| 5074 | Pinnacle® Intelligent Housekeeping Cart with Built-In Divider | 1 | BLA | 650748881 | | | 72 |
| 5075 | Battery Charger | 1 | BLA | 650758881 | | | 73 |
| 5076 | Battery Pack | 1 | BLA | 650768881 | | | 73 |
| 5077 | Safety Shield, No Flipped Door | 1 | BLA | 650778881 | PLAT | 650778882 | 69 |
| 5081 | Cleabox Room Service Cart | 1 | BRN | 650818881 | | | 74 |
| 5082 | Cleabox Room Service Cart | 1 | BRN | 650828881 | | | 74 |
| 5083 | Cleabox Room Service Cart | 1 | BRN | 650838881 | | | 74 |
| 5084 | Tool Basket | 1 | BRN | 650848881 | | | 74 |
| 5085 | Lined Bag for 5081 | 1 | BLA | 650858881 | | | 74 |
| 5086 | Lined Bag for 5082 | 1 | BLA | 650868881 | | | 74 |
| 5087 | Lined Bag for 5083 | 1 | BLA | 650878881 | | | 74 |
| 5088 | Collapsible Linen Cart | 1 | GRAY | 650888881 | | | 81, 162 |
| 5089 | Collapsible Linen Cart | 1 | GRAY | 650898881 | | | 81, 162 |
| 5090 | Collapsible Linen Cart | 1 | GRAY | 650908881 | | | 81, 162 |
| 5091 | Cloth/Straw Bag, for 5088 | 2 | BLA | 650918881 | | | 81, 162 |
| 5092 | Cloth/Straw Bag, for 5089 | 2 | BLA | 650928881 | | | 81, 162 |
| 5093 | Cloth/Straw Bag, for 5090 | 2 | BLA | 650938881 | | | 81, 162 |
| 5094 | Cover for 5088 | 2 | BLA | 650948881 | | | 81, 162 |
| 5095 | Fabric Hanging Organizer for 5041 | 2 | BRN | 650958881 | | | 82 |
| 5096 | Fabric Hanging Organizer for 5042 | 2 | BRN | 650968881 | | | 82 |
| 5097 | Cover for 5045/5089 | 2 | BLA | 650978881 | | | 81, 162 |
| 5098 | Cover for 5046/5090 | 2 | BLA | 650988881 | | | 81, 162 |
| 5210 | Wringer for 5211 | 1 | YEL | 652108881 | GRN | 652108883 | 84 |
| | | | BLUE | 652108882 | RED | 652108884 | |
| 5211 | All-in-one Bucket | 1 | YEL | 652118881 | GRN | 652118883 | 84 |
| | | | BLUE | 652118882 | RED | 652118884 | |
| 5221 | Grandmaid® Bucket with Kits | 4 | YEL | 652218881 | GRN | 652218883 | 85, 87 |
| | | | BLUE | 652218882 | RED | 652218884 | |
| | | | BRN | 652218885 | | | |
| 5222 | Grandmaid® Side Press Wringer for 5221 | 2 | YEL | 652228881 | GRN | 652228883 | 85, 87 |
| | | | BLUE | 652228882 | RED | 652228884 | |
| | | | BRN | 652228885 | | | |
| 5223 | Grandmaid® Side Press Combo | 1 | YEL | 652238881 | BRN | 652238882 | 85 |
| 5224 | Grandmaid® Bucket with Kits | 4 | RED | 652248881 | GRN | 652248884 | 85, 86, 87 |
| | | | YEL | 652248882 | BRN | 652248885 | |
| | | | BLUE | 652248883 | | | |
| 5225 | Grandmaid® Side Press Wringer for 5224 | 2 | RED | 652258881 | GRN | 652258884 | 85, 87 |
| | | | YEL | 652258882 | BRN | 652258885 | |
| | | | BLUE | 652258883 | | | |
| 5226 | Grandmaid® Side Press Combo | 1 | YEL | 652268881 | BRN | 652268882 | 85 |
| | | | GRN | 652268883 | RED | 652268884 | |
| | | | BLUE | 652268885 | | | |
| 5227 | Grandmaid® Down Press Wringer for 5224 | 2 | RED | 652278881 | GRN | 652278884 | 86, 87 |
| | | | YEL | 652278882 | BRN | 652278885 | |
| | | | BLUE | 652278883 | | | |
| 5228 | Grandmaid® Down Press Combo | 1 | YEL | 652288881 | BRN | 652288882 | 86 |
| 5229 | Grandmaid® Bucket with Kits | 4 | YEL | 652298881 | | | 85, 86, 87 |
| 5231 | Pail and Mop Strainer Combination | 6 | GRAY | 652318881 | | | 88 |
| 5241 | Double Pails | 6 | GRAY | 652418881 | | | 89 |
| 5242 | Double Pails | 6 | GRAY | 652428881 | | | 89 |
| 5251 | Bucket | 12 | GRAY | 652518881 | RED | 652518882 | 90 |
| | | | YEL | 652518883 | BLUE | 652518884 | |
| | | | GRN | 652518885 | WHT | 652518886 | |
| 5252 | Bucket | 6 | GRAY | 652528881 | RED | 652528882 | 90 |
| | | | YEL | 652528883 | BLUE | 652528884 | |
| | | | GRN | 652528885 | WHT | 652528886 | |
| 5253 | Bucket | 12 | GRAY | 652538881 | BLUE | 652538884 | 90 |
| | | | RED | 652538882 | GRN | 652538885 | |
| | | | YEL | 652538883 | | | |

PRODUCT INDEX

| No. | Product Name | Pack | Color | Order Code | Color | Order Code | Page |
|------|--|------|-------|------------|-------|------------|------------|
| 5254 | Bucket | 6 | GRAY | 652548881 | BLUE | 652548884 | 90 |
| | | | RED | 652548882 | GRN | 652548885 | |
| | | | YEL | 652548883 | | | |
| 5261 | Dirty Water Bucket for 5221 | 2 | YEL | 652618881 | RED | 652618882 | 85, 87 |
| 5262 | Bucket for 5211 | 2 | YEL | 652628881 | GRN | 652628883 | 84 |
| | | | BLUE | 652628882 | RED | 652628884 | |
| 5263 | Dirty Water Bucket for 5224 | 2 | YEL | 652638881 | RED | 652638882 | 85, 86, 87 |
| 5264 | Quadrate Bucket | 6 | YEL | 652648881 | GRN | 652648884 | 77, 90 |
| | | | RED | 652648882 | BLA | 652648885 | |
| | | | BLUE | 652648883 | | | |
| 5265 | Quadrate Bucket | 6 | YEL | 652658881 | BLUE | 652658883 | 90 |
| | | | RED | 652658882 | GRN | 652658884 | |
| 5266 | Drawer | 2 | YEL | 652668881 | BLA | 652668882 | 77 |
| 5267 | Cleaning Bucket (4 colors per set) | 1 | N/A | 652678881 | | | 77 |
| 5268 | Tool Box | 1 | YEL | 652688881 | GRAY | 652688882 | 77 |
| 5271 | Cotton Mop and Handle Combination | 4 | WHT | 652718881 | | | 88 |
| 5272 | Replacement Mop for 5271 | 12 | WHT | 652728881 | | | 88 |
| 5273 | Steel Sponge Mop with Cellulose Head | 6 | BLUE | 652738881 | | | 89 |
| 5274 | Steel Cellulose Replacement Head | 12 | YEL | 652748881 | | | 89 |
| 5275 | PVA Sponge Mop | 4 | BLA | 652758881 | | | 89 |
| 5276 | PVA Sponge Mop Refill | 12 | | 652768881 | | | 89 |
| 5281 | Roller Mop Bucket and Wringer | 1 | MSILV | 652818881 | | | 88 |
| 5300 | Grandmaid® Side Press Combo | 1 | YEL | 653008881 | | | 85 |
| 5301 | Grandmaid® Down Press Wringer for 5224 | 1 | YEL | 653018881 | | | 86 |
| 5310 | Quiet Caster Dolly | 1 | BLA | 653108881 | | | 87 |
| 5311 | Grandmaid® Dual-water Side Press Comb | 1 | YEL | 653118881 | | | 87 |
| 5312 | Grandmaid® Dual-water Down Press Comb | 1 | YEL | 653128881 | | | 87 |
| 5621 | 1cm Cleaning Brush for Pipeline | 12 | WHT | 656218881 | | | 125 |
| 5633 | 1.3cm Cleaning Brush for Pipeline | 12 | WHT | 656338881 | | | 125 |
| 5641 | 1.6cm Cleaning Brush for Pipeline | 12 | WHT | 656418881 | | | 125 |
| 5652 | 1.9cm Cleaning Brush for Pipeline | 12 | WHT | 656528881 | | | 125 |
| 5663 | 2.5cm Cleaning Brush for Pipeline | 12 | WHT | 656638881 | | | 125 |
| 5672 | 3.8cm Cleaning Brush for Pipeline | 12 | WHT | 656728881 | | | 125 |
| 5683 | 5.1cm Cleaning Brush for Pipeline | 12 | WHT | 656838881 | | | 125 |
| 5691 | Round Vegetable Cleaning Brush | 12 | WHT | 656918881 | | | 258 |
| 5692 | Oval Multipurpose Cleaning Brush | 12 | WHT | 656928881 | | | 258 |
| 5701 | Bottle Cleaning Brush | 12 | WHT | 657018881 | | | 258 |
| 5702 | Bottle Cleaning Brush | 12 | WHT | 657028881 | | | 258 |
| 5711 | Hook-shaped Brush for Pipeline | 12 | RED | 657118881 | GRN | 657118884 | 125 |
| | | | YEL | 657118882 | WHT | 657118885 | |
| | | | BLUE | 657118883 | | | |
| 5712 | Circular Brush for Pipeline | 12 | RED | 657128881 | GRN | 657128884 | 125 |
| | | | YEL | 657128882 | WHT | 657128885 | |
| | | | BLUE | 657128883 | | | |
| 5721 | 0.63cm Pipe Opening Brush | 12 | WHT | 657218881 | | | 263 |
| 5722 | 0.95cm Pipe Opening Brush | 12 | WHT | 657228881 | | | 263 |
| 5723 | 1.9-3.8cm Pipe Opening Brush | 12 | WHT | 657238881 | | | 263 |
| 5724 | 1.27-2.54cm Pipe Opening Brush | 12 | WHT | 657248881 | | | 263 |
| 5731 | 3.5cm High-temperature Cleaning Brush | 12 | WHT | 657318881 | | | 263 |
| 5732 | 2.2cm L-shaped High-temperature Cleaning Brush | 12 | WHT | 657328881 | | | 263 |
| 5733 | 5cm L-shaped High-temperature Cleaning Brush | 12 | WHT | 657338881 | | | 263 |
| 5734 | 5cm Ring-shaped High-temperature Cleaning Brush | 6 | WHT | 657348881 | | | 263 |
| 5741 | 3.8cm Semicircular Coffee Machine Cleaning Brush | 12 | WHT | 657418881 | | | 263 |
| 5742 | 1.6cm Coffee Machine Cleaning Brush | 12 | WHT | 657428881 | | | 263 |
| 6013 | Blend Mop | 6 | WHT | 660138881 | GRN | 660138883 | 94 |
| | | | BLUE | 660138882 | RED | 660138884 | |
| 6014 | Blend Mop | 6 | WHT | 660148881 | GRN | 660148883 | 94 |
| | | | BLUE | 660148882 | RED | 660148884 | |
| 6015 | Blend Mop | 6 | WHT | 660158881 | GRN | 660158883 | 94 |
| | | | BLUE | 660158882 | RED | 660158884 | |
| 6016 | Blend Mop | 6 | WHT | 660168881 | GRN | 660168883 | 94 |
| | | | BLUE | 660168882 | RED | 660168884 | |
| 6023 | Cotton Mop | 12 | WHT | 660238881 | | | 94 |
| 6024 | Cotton Mop | 12 | WHT | 660248881 | | | 94 |

| No. | Product Name | Pack | Color | Order Code | Color | Order Code | Page |
|------|---|------|--------------|------------|-------|------------|------|
| 6025 | Cotton Mop | 12 | WHT | 660258881 | | | 94 |
| 6026 | Cotton Mop | 12 | WHT | 660268881 | | | 94 |
| 6033 | Medium Superfine Fiber Mop | 12 | WHT | 660338881 | | | 94 |
| 6034 | Large Superfine Fiber Mop | 12 | WHT | 660348881 | | | 94 |
| 6035 | Superfine Fiber Mop | 12 | WHT | 660358881 | | | 94 |
| 6036 | Superfine Fiber Mop | 12 | WHT | 660368881 | | | 94 |
| 6043 | Finish Mop | 6 | WHT/ BLUE | 660438882 | | | 95 |
| 6044 | Finish Mop | 6 | WHT/ BLUE | 660448882 | | | 95 |
| 6053 | Clean Room Mop, Medium | 12 | WHT | 660538881 | | | 95 |
| 6054 | Clean Room Mop, Large | 12 | WHT | 660548881 | | | 95 |
| 6055 | Clean Room Mop, Medium | 12 | WHT | 660558881 | | | 95 |
| 6056 | Clean Room Mop, Large | 12 | WHT | 660568881 | | | 95 |
| 6062 | Superfine Fiber Mop | 12 | WHT | 660628881 | | | 96 |
| 6063 | Superfine Fiber Mop | 12 | WHT | 660638881 | | | 96 |
| 6064 | Superfine Fiber Mop With Plastic Threaded Tip | 12 | WHT | 660648881 | | | 96 |
| 6065 | Super Fiber Mop | 12 | WHT | 660658881 | | | 96 |
| 6066 | Super Fiber Mop | 12 | WHT | 660668881 | | | 96 |
| 6072 | Quick Connect Mop | 24 | WHT | 660728881 | GRN | 660728883 | 97 |
| | | | BLUE | 660728882 | RED | 660728884 | |
| 6073 | Quick Connect Mop | 24 | WHT | 660738881 | GRN | 660738883 | 97 |
| | | | BLUE | 660738882 | RED | 660738884 | |
| 6082 | Microfiber Tube Mop | 6 | GRN | 660828881 | | | 96 |
| 6083 | Microfiber Tube Mop | 6 | GRN | 660838881 | | | 96 |
| 6084 | Microfiber Tube Mop | 6 | GRN | 660848881 | | | 96 |
| 6085 | Microfiber Tube Mop | 6 | GRN | 660858881 | | | 96 |
| 6092 | Microfiber String Mop | 6 | GRN | 660928881 | | | 97 |
| 6093 | Microfiber String Mop | 6 | GRN | 660938881 | | | 97 |
| 6094 | Microfiber String Mop | 6 | GRN | 660948881 | | | 97 |
| 6095 | Microfiber String Mop | 6 | GRN | 660958881 | | | 97 |
| 6103 | Antibiotic Blended Mop | 6 | GRN | 661038881 | | | 98 |
| 6104 | Antibiotic Blended Mop | 6 | GRN | 661048881 | | | 98 |
| 6105 | Antibiotic Blended Mop | 6 | GRN | 661058881 | | | 98 |
| 6106 | Antibiotic Blended Mop | 6 | GRN | 661068881 | | | 98 |
| 6112 | Economy Cotton Mop, Small | 12 | WHT | 661128881 | | | 95 |
| 6113 | Economy Cotton Mop, Small | 12 | WHT | 661138881 | | | 95 |
| 6123 | Antibiotic Microfiber Mop | 6 | GRN | 661238881 | | | 98 |
| 6124 | Antibiotic Microfiber Mop | 6 | GRN | 661248881 | | | 98 |
| 6125 | Antibiotic Microfiber Mop | 6 | GRN | 661258881 | | | 98 |
| 6126 | Antibiotic Microfiber Mop | 6 | GRN | 661268881 | | | 98 |
| 6133 | Medium Synthetic Fiber Mop | 6 | WHT | 661338881 | GRN | 661338883 | 98 |
| | | | BLUE | 661338882 | RED | 661338884 | |
| 6134 | Large Synthetic Fiber Mop | 6 | WHT | 661348881 | GRN | 661348883 | 98 |
| | | | BLUE | 661348882 | RED | 661348884 | |
| 6135 | Medium Synthetic Fiber Mop | 6 | WHT | 661358881 | GRN | 661358883 | 98 |
| | | | BLUE | 661358882 | RED | 661358884 | |
| 6136 | Large Synthetic Fiber Mop | 6 | WHT | 661368881 | GRN | 661368883 | 98 |
| | | | BLUE | 661368882 | RED | 661368884 | |
| 6311 | Side Gate Mop Handle | 12 | RED | 663118881 | GRN | 663118883 | 100 |
| | | | BLUE | 663118882 | GRAY | 663118884 | |
| | | | YEL | 663118885 | | | |
| 6312 | Side Gate Mop Handle | 12 | RED | 663128881 | GRN | 663128883 | 100 |
| | | | BLUE | 663128882 | GRAY | 663128884 | |
| | | | YEL | 663128885 | | | |
| 6313 | Side Gate Mop Handle | 12 | LAC | 663138881 | | | 100 |
| 6314 | Side Gate Mop Handle | 12 | LAC | 663148881 | | | 100 |
| 6315 | Side Gate Mop Handle | 12 | MSILV | 663158881 | | | 100 |
| 6316 | Side Gate Mop Handle | 12 | MSILV | 663168881 | | | 100 |
| 6321 | Clamp Style Mop Handle | 12 | RED | 663218881 | GRN | 663218883 | 100 |
| | | | BLUE | 663218882 | GRAY | 663218884 | |
| | | | YEL | 663218885 | | | |
| 6322 | Clamp Style Mop Handle | 12 | RED | 663228881 | GRN | 663228883 | 100 |
| | | | BULE | 663228882 | GRAY | 663228884 | |
| | | | YEL | 663228885 | | | |

PRODUCT INDEX

| No. | Product Name | Pack | Color | Order Code | Color | Order Code | Page |
|------|---|------|-------|------------|-------|------------|----------|
| 6323 | Clamp Style Mop Handle | 12 | RED | 663238881 | GRN | 663238883 | 100 |
| | | | BLUE | 663238882 | GRAY | 663238884 | |
| | | | YEL | 663238885 | | | |
| 6324 | Clamp Style Mop Handle | 12 | RED | 663248881 | GRN | 663248883 | 100 |
| | | | BLUE | 663248882 | GRAY | 663248884 | |
| | | | YEL | 663248885 | | | |
| 6325 | Clamp Style Mop Handle, Hardwood Handle | 12 | LAC | 663258881 | | | 100 |
| 6326 | Clamp Style Mop Handle, Hardwood Handle | 12 | LAC | 663268881 | | | 100 |
| 6327 | Clamp Style Mop Handle | 12 | MSILV | 663278881 | | | 100 |
| 6328 | Clamp Style Mop Handle | 12 | MSILV | 663288881 | | | 100 |
| 6331 | Hinged Side Gate Mop Handle | 12 | BLUE | 663318881 | | | 101 |
| 6332 | Hinged Side Gate Mop Handle | 12 | BLUE | 663328881 | | | 101 |
| 6341 | Steel Mop Handle, Hardwood Handle | 12 | LAC | 663418881 | | | 101 |
| 6342 | Steel Mop Handle, Hardwood Handle | 12 | LAC | 663428881 | | | 101 |
| 6350 | Steel Broom Handle, Threaded | 12 | BLA | 663508881 | | | 121 |
| 6351 | Steel Broom Handle, with Threaded Tips | 12 | BLUE | 663518881 | YEL | 663518883 | 121 |
| | | | RED | 663518882 | GRN | 663518884 | |
| 6352 | Wood Handle, Threaded | 12 | LAC | 663528881 | | | 121 |
| 6353 | Wood Handle, Threaded | 12 | LAC | 663538881 | | | 121 |
| 6362 | Wood Handle, Tapered | 12 | LAC | 663628881 | | | 121 |
| 6363 | Wood Handle, Tapered | 12 | LAC | 663638881 | | | 121 |
| 6388 | Wood Handle, Threaded Metal Tip | 12 | LAC | 663888881 | | | 121 |
| 6389 | Steel Broom Handle, with Metal Threaded Tips | 12 | BLA | 663898881 | | | 121 |
| 6411 | Naelc® 51.0-102.0cm Quick-connect Short Extension Handle | 6 | YEL | 664118881 | | | 103 |
| 6412 | Naelc® 122.0-183.0cm Quick-connect Straight Extension Handle | 6 | YEL | 664128881 | | | 103 |
| 6413 | Naelc® Quick Connect Handle | 12 | YEL | 664138881 | RED | 664138882 | 101 |
| | | | BLUE | 664138883 | GRN | 664138884 | |
| | | | GRAY | 664138885 | | | |
| 6414 | Naelc® Quick Connect Handle | 12 | YEL | 664148881 | BLUE | 664148883 | 101 |
| | | | RED | 664148882 | GRN | 664148884 | |
| 6415 | Naelc® Quick-connect Adapter | 3 | BLA | 664158881 | | | 101, 103 |
| 6416 | Naelc® Quick Connect Handle | 6 | YEL | 664168881 | | | 103 |
| 6417 | Naelc® Quick Connect Handle | 6 | YEL | 664178881 | | | 103 |
| 6420 | Naelc® 28cm Quick-connect Wall/Stair Frame | 6 | BLA | 664208881 | | | 103 |
| 6421 | Naelc® 46cm Quick-connect Frame | 6 | BLA | 664218881 | | | 103 |
| 6422 | Naelc® 61cm Quick-connect Frame | 6 | BLA | 664228881 | | | 103 |
| 6423 | Naelc® 91cm Quick-connect Frame | 6 | BLA | 664238881 | | | 103 |
| 6424 | Naelc® 122cm Quick-connect Frame | 6 | BLA | 664248881 | | | 103 |
| 6425 | Naelc® 152cm Quick-connect Frame | 6 | BLA | 664258881 | | | 103 |
| 6431 | U-Rag® Microfiber Bathroom Cloth | 12 | YEL | 664318881 | | | 108 |
| 6432 | U-Rag® Microfiber General Purpose Cloth | 12 | GRN | 664328881 | BLUE | 664328883 | 108 |
| | | | RED | 664328882 | | | |
| 6433 | U-Rag® Microfiber Glass/Mirror Cloth | 12 | BLUE | 664338881 | | | 108 |
| 6434 | U-Rag® Microfiber XL General Purpose Cloth | 12 | GRN | 664348881 | | | 108 |
| 6435 | U-Rag® Microfiber Bathroom Cloth | 12 | YEL | 664358881 | | | 108 |
| 6436 | U-Rag® Microfiber General Purpose Cloth | 12 | GRN | 664368881 | BLUE | 664368883 | 108 |
| | | | RED | 664368882 | | | |
| 6437 | U-Rag® Microfiber Glass/Mirror Cloth | 12 | BLUE | 664378881 | | | 108 |
| 6441 | U-Rag® Microfiber All Purpose Mitt with Thumb | 12 | GRN | 664418881 | | | 109 |
| 6442 | U-Rag® Microfiber Glass/Mirror Mitt with Thumb | 12 | BLUE | 664428881 | | | 109 |
| 6443 | U-Rag® Microfiber Dusting Mitt with Thumb | 6 | GRN | 664438881 | | | 109 |
| 6451 | U-Rag® Quick-Connect Flexible Dusting Wand with Microfiber Sleeve | 6 | GRN | 664518881 | | | 110 |
| 6452 | U-Rag® Wand Duster Microfiber Replacement Sleeve | 6 | GRN | 664528881 | | | 110 |
| 6453 | U-Rag® Quick-Connect Flexible Dusting Wand with High Performance Sleeve | 6 | WHT | 664538881 | | | 110 |
| 6454 | U-Rag® Wand Duster High Performance Microfiber Replacement Sleeve | 6 | WHT | 664548881 | | | 110 |
| 6461 | Naelc® 46cm Microfiber Fringed Dust Mop | 6 | GRN | 664618881 | | | 104 |
| 6462 | Naelc® 61cm Microfiber Fringed Dust Mop | 6 | GRN | 664628881 | | | 104 |
| 6463 | Naelc® 91cm Microfiber Fringed Dust Mop | 6 | GRN | 664638881 | | | 104 |
| 6464 | Naelc® 122cm Microfiber Fringed Dust Mop | 6 | GRN | 664648881 | | | 104 |
| 6465 | Naelc® 152cm Microfiber Fringed Dust Mop | 6 | GRN | 664658881 | | | 104 |
| 6471 | Naelc® 46cm Microfiber Room Dust Mop | 12 | GRN | 664718881 | WHT | 664718882 | 104 |

| No. | Product Name | Pack | Color | Order Code | Color | Order Code | Page |
|------|--|------|-------|------------|-------|------------|----------|
| 6472 | Naelc® 61cm Microfiber Hall Dust Mop | 12 | GRN | 664728881 | | | 104 |
| 6473 | Naelc® 91cm Microfiber Hall Dust Mop | 12 | GRN | 664738881 | | | 104 |
| 6474 | Naelc® 122cm Microfiber Hall Dust Mop | 12 | GRN | 664748881 | | | 104 |
| 6481 | U-Rag® Superfine Fiber Cloth | 144 | RED | 664818881 | | | 109, 265 |
| 6482 | U-Rag® Superfine Fiber Cloth | 144 | YEL | 664828881 | | | 109, 265 |
| 6483 | U-Rag® Superfine Fiber Cloth | 144 | BLUE | 664838881 | | | 109, 265 |
| 6484 | U-Rag® Superfine Fiber Cloth | 144 | GRN | 664848881 | | | 109, 265 |
| 6485 | U-Rag® Light Microfiber Cloth | 144 | RED | 664858881 | | | 108 |
| 6486 | U-Rag® Light Microfiber Cloth | 144 | YEL | 664868881 | | | 108 |
| 6487 | U-Rag® Light Microfiber Cloth | 144 | BLUE | 664878881 | | | 108 |
| 6488 | U-Rag® Light Microfiber Cloth | 144 | GRN | 664888881 | | | 108 |
| 6500 | Naelc® 28cm Microfiber Damp Room Mop | 6 | BLUE | 665008881 | | | 104 |
| 6501 | Naelc® 46cm Microfiber Super Scrubber Mop | 6 | YEL | 665018881 | | | 104 |
| 6502 | Naelc® 46cm Microfiber Damp Room Mop | 12 | BLUE | 665028881 | RED | 665028883 | 104 |
| | | | GRN | 665028882 | | | |
| 6503 | Naelc® 61cm Microfiber Damp Room Mop | 12 | BLUE | 665038881 | | | 104 |
| 6511 | Naelc® Snap-on Wire Dust Mop Handle | 12 | LAC | 665118881 | | | 105 |
| 6512 | Wedge Mop Handle and Frame | 12 | LAC | 665128881 | | | 105 |
| 6513 | Naelc® Snap-on Wire Dust Mop Handle | 12 | MSILV | 665138881 | | | 105 |
| 6520 | Naelc® Dust Mop Frame | 12 | BLA | 665208881 | | | 105 |
| 6521 | Naelc® Dust Mop Frame | 12 | BLA | 665218881 | | | 105 |
| 6522 | Naelc® Dust Mop Frame | 12 | BLA | 665228881 | | | 105 |
| 6523 | Naelc® Dust Mop Frame | 12 | BLA | 665238881 | | | 105 |
| 6524 | Naelc® Dust Mop Frame | 12 | BLA | 665248881 | | | 105 |
| 6530 | Naelc® Dust Mop | 12 | WHT | 665308881 | BLUE | 665308882 | 105 |
| 6531 | Naelc® Dust Mop | 12 | WHT | 665318881 | BLUE | 665318882 | 105 |
| 6532 | Naelc® Dust Mop | 12 | WHT | 665328881 | BLUE | 665328882 | 105 |
| 6533 | Naelc® Dust Mop | 12 | WHT | 665338881 | BLUE | 665338882 | 105 |
| 6534 | Naelc® Dust Mop | 12 | WHT | 665348881 | BLUE | 665348882 | 105 |
| 6561 | Wedge Mop Dust Mop Head, Looped-end | 12 | YEL | 665618881 | | | 105 |
| 6562 | Wedge Mop Dust Mop Head, Cut-end | 12 | YEL | 665628881 | | | 105 |
| 6571 | U-Rag® Light Microfiber Cloth | 144 | RED | 665718881 | | | 108 |
| 6572 | U-Rag® Light Microfiber Cloth | 144 | YEL | 665728881 | | | 108 |
| 6573 | U-Rag® Light Microfiber Cloth | 144 | BLUE | 665738881 | | | 108 |
| 6574 | U-Rag® Light Microfiber Cloth | 144 | GRN | 665748881 | | | 108 |
| 6601 | Steel Scouring Pad Bracket | 12 | BLUE | 666018881 | | | 123 |
| 6602 | Light Scouring Pad | 12 | WHT | 666028881 | | | 123 |
| 6603 | Medium Scouring Pad | 12 | BLUE | 666038881 | | | 123 |
| 6604 | Medium Scouring Pad | 12 | BLA | 666048881 | | | 123 |
| 6605 | Light Scouring Pad Brush | 12 | WHT | 666058881 | | | 123 |
| 6606 | Medium Scouring Pad Brush | 12 | BLUE | 666068881 | | | 123 |
| 6607 | Heavy-duty Scouring Pad Brush | 12 | BLA | 666078881 | | | 123 |
| 6611 | Potato Cleaning Brush | 12 | WHT | 666118881 | | | 258 |
| 6613 | Angle Broom | 12 | YEL | 666138882 | | | 114 |
| 6621 | Angle Broom with Handle, PET Fill | 6 | YEL | 666218881 | BLA | 666218882 | 114 |
| 6622 | Angle Broom, PP Fill | 12 | YEL | 666228881 | | | 114 |
| 6623 | Angle Broom, PET Fill | 12 | RED | 666238881 | GRN | 666238884 | 114, 262 |
| | | | YEL | 666238882 | WHT | 666238885 | |
| | | | BLUE | 666238883 | BLA | 666238886 | |
| 6624 | Angle Broom with Handle, PET Fill | 12 | BLA | 666248881 | | | 114 |
| 6632 | Plastic Foam Block, Fine Floor Sweep, PET Fill | 12 | BLA | 666328881 | YEL | 666328882 | 114 |
| 6633 | Plastic Foam Block, Fine Floor Sweep, PET Fill | 12 | BLA | 666338881 | YEL | 666338882 | 114 |
| 6634 | Handwood Foam Block, Fine Floor Sweep, PET Fill | 2 | LAC | 666348881 | | | 114 |
| 6642 | Plastic Foam Block, Fine Floor Sweep, Tampico Fill with Horsehair Border | 12 | BLA | 666428881 | YEL | 666428882 | 114 |
| 6643 | Plastic Foam Block, Fine Floor Sweep, Tampico Fill with Horsehair Border | 12 | BLA | 666438881 | YEL | 666438882 | 114 |
| 6644 | Hardwood Block, Fine Floor Sweep, Tampico Fill with Horsehair Border | 2 | LAC | 666448881 | | | 114 |
| 6652 | Plastic Foam Block, Medium Floor Sweep, PP Fill | 12 | BLA | 666528881 | YEL | 666528882 | 115 |
| 6653 | Plastic Foam Block, Medium Floor Sweep, PP Fill | 12 | BLA | 666538881 | YEL | 666538882 | 115 |
| 6654 | Hardwood Block, Medium Floor Sweep, PP Fill | 2 | LAC | 666548881 | | | 115 |
| 6662 | Plastic Foam Block, Medium Floor Sweep, Tampico Fill | 12 | BLA | 666628881 | YEL | 666628882 | 115 |
| 6663 | Plastic Foam Block, Medium Floor Sweep, Tampico Fill | 12 | BLA | 666638881 | YEL | 666638882 | 115 |
| 6664 | Hardwood Block, Medium Floor Sweep, Tampico Fill | 2 | LAC | 666648881 | | | 115 |

PRODUCT INDEX

| No. | Product Name | Pack | Color | Order Code | Color | Order Code | Page |
|------|--|------|-------|------------|-------|------------|------|
| 6672 | Plastic Foam Block, Medium Floor Sweep, PET and PP Fill | 12 | BLA | 666728881 | YEL | 666728882 | 115 |
| 6673 | Plastic Foam Block, Medium Floor Sweep, PET and PP Fill | 12 | BLA | 666738881 | YEL | 666738882 | 115 |
| 6674 | Hardwood Block, Medium Floor Sweep, PET and PP Fill | 2 | LAC | 666748881 | | | 115 |
| 6682 | Plastic Foam Block, Heavy-Duty Floor Sweep, PP Fill | 12 | BLA | 666828881 | YEL | 666828882 | 115 |
| 6683 | Plastic Foam Block, Heavy-Duty Floor Sweep, PP Fill | 12 | BLA | 666838881 | YEL | 666838882 | 115 |
| 6684 | Hardwood Block, Heavy-Duty Floor Sweep, PP Fill | 2 | LAC | 666848881 | | | 115 |
| 6692 | Plastic Foam Block, Heavy-Duty Floor Sweep, Palmyra Fill | 12 | BLA | 666928881 | YEL | 666928882 | 115 |
| 6693 | Plastic Foam Block, Heavy-Duty Floor Sweep, Palmyra Fill | 12 | BLA | 666938881 | YEL | 666938882 | 115 |
| 6694 | Hardwood Block, Heavy-Duty Floor Sweep, Palmyra Fill | 2 | LAC | 666948881 | | | 115 |
| 6695 | 45cm Floor Sweep, PET Fill | 12 | RED | 666958881 | GRN | 666958884 | 260 |
| | | | YEL | 666958882 | WHT | 666958885 | |
| | | | BLUE | 666958883 | | | |
| 6696 | 61cm Floor Sweep, PET Fill | 12 | RED | 666968881 | GRN | 666968884 | 260 |
| | | | YEL | 666968882 | WHT | 666968885 | |
| | | | BLUE | 666968883 | | | |
| 6701 | Counter Brush, PET Fill | 6 | BLA | 667018881 | YEL | 667018882 | 119 |
| 6702 | Counter Brush, PP Fill | 6 | BLA | 667028881 | YEL | 667028882 | 119 |
| 6703 | Counter Brush, Tampico Fill | 6 | BLA | 667038881 | YEL | 667038882 | 119 |
| 6704 | Counter Brush, PET Fill | 6 | BLA | 667048881 | YEL | 667048882 | 119 |
| 6705 | Counter Brush, PET Fill | 12 | RED | 667058881 | GRN | 667058884 | 260 |
| | | | YEL | 667058882 | WHT | 667058885 | |
| | | | BLUE | 667058883 | | | |
| 6706 | Counter Brush, PET Fill | 12 | RED | 667068881 | GRN | 667068884 | 260 |
| | | | YEL | 667068882 | WHT | 667068885 | |
| | | | BLUE | 667068883 | | | |
| 6712 | Short Plastic Handle Utility Brush, Palmyra Fill | 6 | BLA | 667128881 | YEL | 667128882 | 119 |
| 6713 | Long Plastic Handle Utility Brush, Palmyra Fill | 6 | BLA | 667138881 | YEL | 667138882 | 119 |
| 6714 | Short Handle Multi-purpose Cleaning Brush, PET Fill | 12 | RED | 667148881 | GRN | 667148884 | 261 |
| | | | YEL | 667148882 | WHT | 667148885 | |
| | | | BLUE | 667148883 | | | |
| 6722 | Short Plastic Handle Utility Brush, PP Fill | 6 | BLA | 667228881 | YEL | 667228882 | 119 |
| 6723 | Long Plastic Handle Utility Brush, PP Fill | 6 | BLA | 667238881 | YEL | 667238882 | 119 |
| 6724 | Long Handle Multi-purpose Cleaning Brush, PET Fill | 12 | RED | 667248881 | GRN | 667248884 | 261 |
| | | | YEL | 667248882 | WHT | 667248885 | |
| | | | BLUE | 667248883 | | | |
| 6725 | Chopping Board Cleaning Brush, PP Fill | 12 | RED | 667258881 | GRN | 667258884 | 261 |
| | | | YEL | 667258882 | WHT | 667258885 | |
| | | | BLUE | 667258883 | BRN | 667258886 | |
| 6726 | Chopping Board Cleaning Brush, PP Fill | 12 | RED | 667268881 | GRN | 667268884 | 261 |
| | | | YEL | 667268882 | WHT | 667268885 | |
| | | | BLUE | 667268883 | BRN | 667268886 | |
| 6727 | Three Heads Glass Brush | 6 | BLA | 667278881 | | | 261 |
| 6728 | Two Heads Glass Brush | 6 | BLA | 667288881 | | | 261 |
| 6729 | Standard Glass Brush Head | 12 | BLA | 667298881 | | | 261 |
| 6732 | Short Plastic Handle Utility Brush, Tampico Fill | 6 | BLA | 667328881 | YEL | 667328882 | 119 |
| 6733 | Long Plastic Handle Utility Brush, Tampico Fill | 6 | BLA | 667338881 | YEL | 667338882 | 119 |
| 6743 | Deck Brush, Tampico and PP Fill | 12 | BLA | 667438881 | YEL | 667438882 | 120 |
| 6746 | Wash Brush, PVC Fill | 6 | BLA | 667468881 | YEL | 667468882 | 120 |
| 6747 | Wash Brush, Nylon Fill | 6 | BLA | 667478881 | YEL | 667478882 | 120 |
| 6751 | Square Block Scrub Brush, PP Fill | 12 | BLA | 667518881 | YEL | 667518882 | 120 |
| 6752 | Wash Brush, PP Fill | 6 | BLA | 667528881 | YEL | 667528882 | 120 |
| 6753 | Floor Scrub, Plastic Block Tampico Fill | 12 | BLA | 667538881 | YEL | 667538882 | 120 |
| 6754 | Wash Brush, Round Block, PP Fill | 6 | BLA | 667548881 | YEL | 667548882 | 120 |
| 6755 | Pointed Scrub Brush, Tampico Fill | 12 | BLA | 667558881 | YEL | 667558882 | 120 |
| 6756 | Pointed Scrub Brush, PP Fill | 12 | BLA | 667568881 | YEL | 667568882 | 120 |
| 6757 | Cleaning Brush, PP Fill | 12 | RED | 667578881 | GRN | 667578884 | 261 |
| | | | YEL | 667578882 | WHT | 667578885 | |
| | | | BLUE | 667578883 | | | |
| 6758 | Cleaning Brush, PP Fill | 12 | RED | 667588881 | GRN | 667588884 | 261 |
| | | | YEL | 667588882 | WHT | 667588885 | |
| | | | BLUE | 667588883 | | | |
| 6759 | Cleaning Brush, PP Fill | 12 | RED | 667598881 | GRN | 667598884 | 261 |
| | | | YEL | 667598882 | WHT | 667598885 | |
| | | | BLUE | 667598883 | | | |

| No. | Product Name | Pack | Color | Order Code | Color | Order Code | Page |
|------|--|------|-------|------------|-------|------------|----------|
| 6760 | Cleaning Brush, PP Fill | 12 | RED | 667608881 | GRN | 667608884 | 261 |
| | | | YEL | 667608882 | WHT | 667608885 | |
| | | | BLUE | 667608883 | | | |
| 6761 | Stainless Steel Wire Brush | 12 | BLA | 667618881 | YEL | 667618882 | 118 |
| 6762 | Condenser Cleaning Brush | 12 | YEL | 667628881 | | | 124 |
| 6763 | Three-sided Shoe Brush | 1 | BLA | 667638881 | | | 125 |
| 6764 | 30cm Wire Brush | 12 | BLA | 667648881 | YEL | 667648882 | 118 |
| 6765 | Wire Brush with Scraper | 12 | BLA | 667658881 | YEL | 667658882 | 118 |
| 6766 | Square Block Scrub Brush, Palmyra Fill | 12 | BLA | 667668881 | YEL | 667668882 | 120 |
| 6773 | 28cm Wire Brush | 12 | BLA | 667738881 | YEL | 667738882 | 118 |
| 6774 | Fan Duster Brush | 6 | BLA | 667748881 | | | 124 |
| 6775 | Duster Brush | 6 | BLA | 667758881 | | | 124 |
| 6782 | Tile and Grout Brush, Nylon Bristles | 12 | YEL | 667828882 | | | 120 |
| 6783 | Tile and Grout Brush, Brass Bristles | 12 | YEL | 667838882 | | | 118 |
| 6784 | Deck Brush, Plastic Block, Tampico Fill | 12 | BLA | 667848881 | YEL | 667848882 | 120 |
| 6785 | Toilet Bowl Brush Holder | 6 | RED | 667858881 | GRN | 667858884 | 122 |
| | | | YEL | 667858882 | WHT | 667858885 | |
| | | | BLUE | 667858883 | | | |
| 6786 | Iron Handle Scrub Brush, PP Fill | 12 | YEL | 667868882 | | | 120 |
| 6787 | Plastic Hand and Nail Brush, Nylon Fill | 12 | WHT | 667878881 | | | 120 |
| 6788 | Toilet Bowl Brush | 12 | WHT | 667888881 | | | 122 |
| 6789 | Tapered Toilet Bowl Brush | 12 | WHT | 667898881 | | | 122 |
| 6790 | Bathtub Brush | 12 | WHT | 667908881 | | | 122 |
| 6791 | Toilet Bowl Brush, Hardwood Handle, PP Fill | 12 | YEL | 667918881 | | | 118 |
| 6792 | Toilet Bowl Brush, Plastic Handle, PP Fill | 24 | WHT | 667928881 | | | 118 |
| 6793 | Toilet Bowl Brush Holder | 24 | WHT | 667938881 | | | 118 |
| 6794 | Toilet Bowl Brush, Plastic Handle, PP Fill | 12 | BLA | 667948881 | YEL | 667948882 | 118 |
| 6795 | Plastic Handle Bowl Brush, PP Fill | 12 | YEL | 667958882 | | | 118 |
| 6796 | Plastic Handle Bowl Brush | 12 | YEL | 667968881 | | | 118 |
| 6797 | Plastic Handle Bowl Brush | 12 | YEL | 667978881 | | | 118 |
| 6798 | 8x42cm Toilet Bowl Brushes | 12 | WHT | 667988881 | | | 118 |
| 6801 | Corn Whisk Broom | 12 | BLUE | 668018881 | | | 124 |
| 6802 | Labby Broom, 100% Corn Fill | 12 | RED | 668028881 | | | 124 |
| 6803 | Corn Broom, Standard, 2.5cm Stained/Lacquered Handle | 12 | RED | 668038881 | | | 124 |
| 6804 | Corn Broom, Warehouse, 2.9cm Stained/Lacquered Handle | 12 | RED | 668048881 | | | 124 |
| 6805 | Corn Broom, Warehouse, 2.9cm Stained/Lacquered Handle | 12 | RED | 668058881 | | | 124 |
| 6814 | 46cm Straight Floor Squeegee | 6 | BLA | 668148881 | | | 128 |
| 6815 | 61cm Straight Floor Squeegee | 6 | BLA | 668158881 | | | 128 |
| 6816 | 91cm Straight Floor Squeegee | 6 | BLA | 668168881 | | | 128 |
| 6817 | 46cm Replacement Blade | 6 | BLA | 668178881 | | | 128 |
| 6818 | 61cm Replacement Blade | 6 | BLA | 668188881 | | | 128 |
| 6819 | 91cm Replacement Blade | 6 | BLA | 668198881 | | | 128 |
| 6825 | 61cm Curved Floor Squeegee | 6 | BLA | 668258881 | | | 128 |
| 6831 | 46cm Plastic Professional Squeegee with Black Dual Moss Rubber | 10 | RED | 668318881 | YEL | 668318883 | 129, 260 |
| | | | BLUE | 668318882 | GRN | 668318884 | |
| 6841 | 46cm Standard Floor Squeegee | 10 | BLA | 668418881 | | | 128 |
| 6842 | 56cm Standard Floor Squeegee | 10 | BLA | 668428881 | | | 128 |
| 6843 | 56cm Heavy-duty Floor Squeegee | 10 | BLA | 668438881 | | | 128 |
| 6844 | 76cm Heavy-duty Floor Squeegee | 10 | BLA | 668448881 | | | 128 |
| 6851 | Light Wooden Floor Sweep, PP Fill | 6 | LAC | 668518881 | | | 116 |
| 6852 | Medium Wooden Floor Sweep, PP Fill | 6 | LAC | 668528881 | | | 116 |
| 6853 | Heavy-duty Wooden Floor Sweep, PP Bristles | 6 | LAC | 668538881 | | | 117 |
| 6861 | Light Wooden Floor Sweep, PP Fill | 6 | LAC | 668618881 | | | 116 |
| 6862 | Medium Wooden Floor Sweep, PP Fill | 6 | LAC | 668628881 | | | 116 |
| 6863 | Heavy-duty Wooden Floor Sweep, PP Bristles | 6 | LAC | 668638881 | | | 117 |
| 6871 | Light Wooden Floor Sweep, PP Fill | 6 | LAC | 668718881 | | | 116 |
| 6872 | Medium Wooden Floor Sweep, PP Fill | 6 | LAC | 668728881 | | | 116 |
| 6873 | Heavy-duty Wooden Floor Sweep, PP Bristles | 6 | LAC | 668738881 | | | 117 |
| 6881 | Light Wooden Floor Sweep, PP Fill | 6 | LAC | 668818881 | | | 116 |
| 6882 | Medium Wooden Floor Sweep, PP Fill | 6 | LAC | 668828881 | | | 116 |
| 6883 | Heavy-duty Wooden Floor Sweep, PP Bristles | 6 | LAC | 668838881 | | | 117 |
| 6891 | Light Wooden Floor Sweep, PP Fill | 6 | LAC | 668918881 | | | 116 |
| 6892 | Medium Wooden Floor Sweep, PP Fill | 6 | LAC | 668928881 | | | 116 |
| 6893 | Heavy-duty Wooden Floor Sweep, PP Bristles | 6 | LAC | 668938881 | | | 117 |

PRODUCT INDEX

| No. | Product Name | Pack | Color | Order Code | Color | Order Code | Page |
|------|--|------|-------|------------|-------|------------|----------|
| 6901 | Wall Washer Kit Includes 2 Brushes | 2 | BLA | 669018881 | | | 131 |
| 6902 | Wall Washer Kit Includes 2 Microfiber Brushes | 2 | BLA | 669028881 | | | 131 |
| 6903 | Wall Washer Kit Replacement Brushes | 12 | WHT | 669038881 | | | 131 |
| 6904 | Wall Washer Kit Replacement Microfiber Brushes | 12 | WHT | 669048881 | | | 131 |
| 6911 | Predator Upright Dust Pan with Hook | 6 | BLA | 669118881 | | | 126 |
| 6912 | Predator Upright Dust Pan with Cover | 6 | BLA | 669128881 | | | 126 |
| 6913 | Predator Upright Dust Pan with Cover w/o Hook | 6 | BLA | 669138881 | | | 126 |
| 6914 | Predator Upright Dust Pan w/o Hook | 6 | BLA | 669148881 | | | 126 |
| 6915 | Predator Upright Dust Pan Hanger Bracket | 6 | BLA | 669158881 | | | 126 |
| 6916 | Predator Dry/Wet Dust Pan | 4 | BLA | 669168881 | | | 126 |
| 6917 | Predator Dry/Wet Floor Squeegee | 4 | BLA | 669178881 | | | 126 |
| 6923 | Heavy-duty Dust Pan | 12 | BLA | 669238881 | | | 127 |
| 6924 | Extra Large Dust Pan | 6 | BLA | 669248881 | | | 127 |
| 6925 | Jumbo Dust Pan | 6 | BLA | 669258881 | | | 127 |
| 6926 | Heavy-duty Dust Pan and Counter Brush | 6 | BLA | 669268881 | | | 127 |
| 6927 | Steel Heavy-duty Dust Pan | 6 | BLA | 669278881 | | | 127 |
| 6928 | Steel Heavy-duty Dust Pan | 6 | BLA | 669288881 | | | 127 |
| 6929 | Step&Sweep Dust Pan | 6 | GRAY | 669298881 | | | 127 |
| 6930 | Rotomolded Plastic Pedal | 1 | BLA | 669308881 | YEL | 669308882 | 134, 174 |
| 6931 | Deluxe Carry Caddy | 6 | BLA | 669318881 | | | 136 |
| 6932 | Two-step Folding Stepstool | 3 | GRAY | 669328881 | BLA | 669328882 | 134, 174 |
| | | | DGRAY | 669328883 | | | |
| 6933 | Movable Two-step Pedal | 1 | BLA | 669338881 | BEIG | 669338882 | 134, 174 |
| 6934 | Nozzle | 12 | RED | 669348881 | GRN | 669348884 | 137 |
| | | | YEL | 669348882 | WHT | 669348885 | |
| | | | BLUE | 669348883 | | | |
| 6935 | 950 ml Spray Bottle | 12 | WHT | 669358881 | | | 137 |
| 6936 | Pneumatic Sprayer | 12 | WHT | 669368881 | | | 137 |
| 6937 | Pneumatic Sprayer | 12 | WHT | 669378881 | | | 137 |
| 6938 | Pneumatic Sprayer | 12 | WHT | 669388881 | | | 137 |
| 6939 | Toilet Pump | 12 | BLA | 669398881 | | | 138 |
| 6940 | Toilet Pump | 12 | BLA | 669408881 | | | 138 |
| 6941 | Closet Organizer/Tool Holder Kit | 6 | YEL | 669418881 | BLUE | 669418883 | 132, 265 |
| | | | RED | 669418882 | GRN | 669418884 | |
| 6942 | Closet Organizer/Tool Holder Kit | 4 | YEL | 669428881 | BLUE | 669428883 | 132, 265 |
| | | | RED | 669428882 | GRN | 669428884 | |
| 6943 | Two-step Folding Ladder | 1 | BLA | 669438881 | | | 136, 173 |
| 6944 | Three-step Folding Ladder | 1 | BLA | 669448881 | | | 136, 173 |
| 6945 | Multi-function Ladder | 1 | MSILV | 669458881 | | | 135, 173 |
| 6946 | Multi-function Ladder | 1 | MSILV | 669468881 | | | 135, 173 |
| 6947 | Spray Bottle with Trigger | 12 | RED | 669478881 | | | 137 |
| 6948 | Pedal Sanitary Bin | 1 | WHT | 669488881 | GRAY | 669488882 | 142 |
| 6949 | Pedal Sanitary Bin | 4 | WHT | 669498881 | GRAY | 669498882 | 142 |
| 6950 | Wall-mounted Sanitary Napkin Receptacle | 1 | WHT | 669508881 | | | 142 |
| 6951 | Ironing Organizer | 6 | WHT | 669518881 | BLA | 669518882 | 133 |
| 6952 | 650 ml Spray Bottle | 12 | WHT | 669528881 | | | 137 |
| 6953 | Three-sided Multi-layer Storage Bag for 5021/5022/5023 | 2 | BRN | 669538881 | | | 69 |
| 6954 | Large Capacity of Side Hanging Bag for 5021/5022/5023/5031 | 6 | BRN | 669548881 | | | 69 |
| 6955 | Double-layer Tool Basket | 3 | BLA | 669558881 | | | 136 |
| 6956 | Toilet Brush Holder, for 6955 | 6 | BLA | 669568881 | | | 136 |
| 6961 | Bath Mat | 4 | WHT | 669618881 | BEIG | 669618882 | 142 |
| 6963 | Bath Mat | 4 | WHT | 669638881 | BEIG | 669638882 | 142 |
| 6965 | Bath Mat | 4 | WHT | 669658881 | BEIG | 669658882 | 142 |
| 6966 | Bin Liner Refills (15 Pieces Per Roll), for 6948 | 12 | | 669668881 | | | 142 |
| 6967 | Bin Liner Refills (15 Pieces Per Roll), for 6949 | 12 | | 669678881 | | | 142 |
| 6968 | Canvas Linen Accessory Bag for 5031 | 6 | BRN | 669688881 | | | 71, 73 |
| 6969 | Fabric Mesh Linen Bag for 5031 | 6 | BRN | 669698881 | | | 71, 73 |
| 6970 | Vinyl Bag for 5031 | 6 | BRN | 669708881 | | | 71 |
| 6971 | Zippered Trash Bag for 5011 | 2 | YEL | 669718881 | | | 77 |
| 6972 | Vinyl Bag for 5021/5022/5023 | 6 | BRN | 669728881 | | | 69 |
| 6973 | Canvas Linen Accessory Bag for 5021/5022/5023 | 6 | BRN | 669738881 | | | 69, 73 |
| 6974 | Fabric Mesh Linen Bag for 5021/5022/5023 | 6 | BRN | 669748881 | | | 69, 73 |
| 6975 | Fabric 9-pocket Organizer for 5021/5022/5023/5031 | 6 | BRN | 669758881 | | | 69, 73 |

| No. | Product Name | Pack | Color | Order Code | Color | Order Code | Page |
|------|---|------|--------------------|-------------------------------------|--------------------|-------------------------------------|--------|
| 6976 | Short Polyliner, for 5021/5022/5023/5031 | 6 | BRN | 669768881 | | | 69, 73 |
| 6977 | Cloth/Straw Bag, for 5021/5022/5023 | 6 | BRN | 669778881 | | | 69, 73 |
| 6978 | Polyliner with Side Bag, for 5011 | 2 | YEL BLUE | 669788881 669788882 | GRN RED | 669788883 669788884 | 77 |
| 6979 | Large-capacity Eight-compartment Bag, for 5021/5022/5023 | 6 | BRN | 669798881 | | | 69, 73 |
| 6981 | 8cm Scraper | 6 | BLA | 669818881 | | | 138 |
| 6982 | 4cm Scraper | 6 | BLA | 669828881 | | | 138 |
| 6983 | Heavy-duty Glove, Large | 6 | BLA | 669838881 | | | 133 |
| 6984 | Heavy-duty Glove, Xlarge | 6 | BLA | 669848881 | | | 133 |
| 6985 | Professional Kneepads | 6 | BLA | 669858881 | | | 133 |
| 6986 | Laundry Nets | 12 | WHT | 669868881 | | | 110 |
| 6987 | 76-100cm Lambswool Duster with Telescoping Plastic Handle | 6 | GRAY | 669878881 | | | 130 |
| 6988 | Flexible Head Overhead Dusting Tool, Flexible Head with 152cm Aluminum Handle | 6 | MSILV | 669888881 | | | 130 |
| 6989 | Dust Mitt Off-floor Tool, Cotton | 12 | WHT | 669898881 | | | 130 |
| 6990 | Overhead Dusting Tool with Launderable Head, 130cm Extension Handle | 12 | GRAY | 669908881 | | | 131 |
| 6991 | Overhead Dusting Tool with Angled Launderable Head, 130cm Extension Handle | 12 | GRAY | 669918881 | | | 131 |
| 6992 | Overhead Dusting Tool with Launderable Head, 260cm Extension Handle | 12 | GRAY | 669928881 | | | 131 |
| 6993 | Overhead Dusting Tool Replacement Head, fits 6990/6991/6992 | 12 | WHT | 669938881 | | | 131 |
| 6994 | Dust Brush, Round Block | 12 | BLA | 669948881 | | | 124 |
| 6995 | Ostrich Duster | 12 | LAC | 669958881 | | | 130 |
| 6996 | Nipper | 12 | BLA | 669968881 | | | 138 |
| 6997 | Nipper | 12 | BLA | 669978881 | | | 138 |
| 6998 | Waxed Bag (50 per bundle) | 5 | | 669988881 | | | 142 |
| 7114 | Floor Sign with "Caution Wet Floor" Imprint | 6 | YEL | 671148881 | | | 268 |
| 7121 | Safety Cone Sign | 5 | RED | 671218881 | | | 271 |
| 7122 | Safety Cone Signs with "No Parking" Imprint | 5 | RED | 671228881 | | | 271 |
| 7133 | Stable Safety Sign with "Caution Wet Floor" Imprint | 6 | YEL | 671338881 | | | 269 |
| 7142 | Hanging Safety Sign with "Caution Wet Floor" Imprint | 6 | YEL | 671428881 | | | 269 |
| 7152 | Site Safety Hanging Sign with "Closed for Cleaning" Imprint | 6 | YEL | 671528881 | | | 269 |
| 7161 | Floor Safety Sign with "Repair in Progress" Imprint | 6 | YEL | 671618881 | | | 268 |
| 7162 | Floor Safety Sign with "Cleaning in Progress" Imprint | 6 | YEL | 671628881 | | | 268 |
| 7163 | Floor Safety Sign with "Out of Service" Imprint | 6 | YEL | 671638881 | | | 268 |
| 7175 | Four-sided Billboard, Printed with the Words "Caution Wet Floor" | 6 | YEL | 671758881 | | | 268 |
| 7176 | Four-sided Billboard, Printed with the Words "Cleaning in Progress" | 6 | YEL | 671768881 | | | 268 |
| 7177 | Four-sided Billboard, Printed with the Words "Out of Service" | 6 | YEL | 671778881 | | | 268 |
| 7178 | Four-sided Billboard, Printed with the Words "Repair in Progress" | 6 | YEL | 671788881 | | | 268 |
| 7181 | Movable Fence, Consisting of 16 Connecting Plates | 1 | YEL | 671818881 | | | 270 |
| 7182 | Movable Fence, Consisting of 12 Connecting Plates | 1 | YEL | 671828881 | | | 270 |
| 7183 | Movable Fence, Consisting of 8 Connecting Plates | 1 | YEL | 671838881 | | | 270 |
| 7313 | Safety Cone With "Caution, Wet Floor" Imprint | 6 | YEL | 673138881 | | | 271 |
| 7315 | Safety Cone With "No Parking" Imprint | 6 | YEL | 673158881 | | | 271 |
| 7323 | Safety Cone With "Caution, Wet Floor" Imprint | 5 | YEL | 673238881 | | | 271 |
| 7333 | Pop-up Safety Cone, 50cm with "Caution, Wet Floor" Imprint | 12 | YEL | 673338881 | | | 272 |
| 7334 | Pop-up Safety Cone, 76cm with "Caution, Wet Floor" Imprint | 12 | YEL | 673348881 | | | 272 |
| 7342 | Folding Safety Cone with "Caution, Wet Floor" Imprint | 12 | YEL | 673428881 | | | 272 |
| 7511 | Barrier Chain | 4 | YEL | 675118881 | | | 271 |
| 7512 | Safety Warning Light | 12 | YEL | 675128881 | | | 271 |
| 7521 | Weight-ring for 7321/7322 | 1 | BLA | 675218881 | | | 271 |
| 8011 | Kid&Cool® Microban® Youth Seat without Wheels | 1 | BLA PLAT | 680118881 680118882 | GRN BRN | 680118883 680118884 | 256 |
| 8012 | Kid&Cool® Microban® Youth Seat with Wheels | 1 | BLA PLAT | 680128881 680128882 | GRN BRN | 680128883 680128884 | 256 |
| 8013 | Tray for 8011/8012/8014 | 1 | GRN PLAT RED | 680138881 680138882 680138883 | BLUE BLA BRN | 680138884 680138885 680138886 | 256 |

PRODUCT INDEX

| No. | Product Name | Pack | Color | Order Code | Color | Order Code | Page |
|------|---|------|-------|------------|-------|------------|----------|
| 8014 | Kid&Cool® Microban® Youth Seat, RTA (Ready to Assemble) no Wheels | 1 | BLA | 680148881 | GRN | 680148883 | 256 |
| | | | PLAT | 680148882 | BRN | 680148884 | |
| | | | BLUE | 680148885 | | | |
| 8015 | Caster Kit | 1 | | 680158881 | | | 256 |
| 8016 | Non-slip Feet Pad Set | 1 | BLA | 680168881 | | | 256 |
| 8021 | Heimdall Baby Changing Station | 1 | LPLAT | 680218881 | | | 140, 260 |
| 8022 | Protective Liners for Baby Changing Station | 16 | WHT | 680228881 | | | 140, 260 |
| 8023 | Heimdall Baby Changing Station | 1 | LPLAT | 680238881 | | | 140, 260 |
| 8031 | Kid&Cool® Microban® Infant Safety Seat | 1 | LPLAT | 680318881 | | | 141, 259 |
| 8211 | Bus/Utility Box | 12 | GRAY | 682118881 | WHT | 682118882 | 254 |
| | | | BRN | 682118883 | | | |
| 8212 | Bus/Utility Box | 12 | GRAY | 682128881 | WHT | 682128882 | 254 |
| 8216 | Lid for 8211/8212 | 12 | GRAY | 682168881 | WHT | 682168882 | 254 |
| 8220 | Bus/Utility Box | 6 | GRAY | 682208881 | BRN | 682208882 | 254 |
| 8221 | Bus/Utility Box | 6 | GRAY | 682218881 | BRN | 682218882 | 254 |
| 8222 | Divided Bus/Utility Box | 6 | GRAY | 682228881 | BRN | 682228882 | 254 |
| 8226 | Lid for 8220/8221/8222 | 6 | GRAY | 682268881 | BRN | 682268882 | 254 |
| 8231 | Cutlery Bin, 4 Compartments | 12 | GRAY | 682318881 | | | 254 |
| 8241 | Catering Disk | 12 | BLA | 682418881 | STRAN | 682418882 | 239 |
| 8250 | Round GRP Non-slip Pallet | 12 | BRN | 682508881 | | | 239 |
| 8251 | Round GRP Non-slip Pallet | 12 | BRN | 682518881 | | | 239 |
| 8252 | Round GRP Non-slip Pallet | 12 | BRN | 682528881 | | | 239 |
| 8253 | Round GRP Non-slip Pallet | 12 | BRN | 682538881 | | | 239 |
| 8254 | Round GRP Non-slip Pallet | 12 | BRN | 682548881 | | | 239 |
| 8255 | Rectangular GRP Non-slip Pallet | 12 | BRN | 682558881 | | | 239 |
| 8256 | Rectangular GRP Non-slip Pallet | 12 | BRN | 682568881 | | | 239 |
| 8257 | Rectangular GRP Non-slip Pallet | 12 | BRN | 682578881 | | | 239 |
| 8258 | Rectangular GRP Non-slip Pallet | 12 | BRN | 682588881 | | | 239 |
| 8259 | Rectangular GRP Non-slip Pallet | 12 | BRN | 682598881 | | | 239 |
| 8260 | Rectangular GRP Non-slip Pallet | 12 | BRN | 682608881 | | | 239 |
| 8261 | Pitcher | 6 | CLR | 682618881 | | | 255 |
| 8262 | Pitcher | 6 | CLR | 682628881 | | | 255 |
| 8263 | Pitcher | 6 | CLR | 682638881 | | | 255 |
| 8264 | Pitcher | 6 | CLR | 682648881 | | | 255 |
| 8265 | Cold Water Bottle | 6 | CLR | 682658881 | | | 255 |
| 8266 | Cold Water Bottle | 6 | CLR | 682668881 | | | 255 |
| 8267 | Oval GRP Non-slip Tray | 6 | BRN | 682678881 | | | 239 |
| 8268 | Oval GRP Non-slip Tray | 6 | BRN | 682688881 | | | 239 |
| 8269 | Oval GRP Non-slip Tray | 6 | BRN | 682698881 | | | 239 |
| 8270 | Round Wood Grain Non-slip Tray | 12 | ASH | 682708881 | WAL | 682708882 | 240 |
| 8271 | Round Wood Grain Non-slip Tray | 12 | ASH | 682718881 | WAL | 682718882 | 240 |
| 8272 | Rectangle Wood Grain Non-slip Tray | 12 | ASH | 682728881 | WAL | 682728882 | 240 |
| 8273 | Rectangle Wood Grain Non-slip Tray | 12 | ASH | 682738881 | WAL | 682738882 | 240 |
| 8274 | Rectangle Wood Grain Non-slip Tray | 12 | ASH | 682748881 | WAL | 682748882 | 240 |
| 8275 | Rectangle Wood Grain Non-slip Tray | 12 | ASH | 682758881 | WAL | 682758882 | 240 |
| 8276 | Oval Wood Grain Non-slip Tray | 12 | ASH | 682768881 | WAL | 682768882 | 240 |
| 8277 | Oval Wood Grain Non-slip Tray | 12 | ASH | 682778881 | WAL | 682778882 | 240 |
| 8278 | Oval Wood Grain Non-slip Tray | 12 | ASH | 682788881 | WAL | 682788882 | 240 |
| 8279 | Oval Wood Grain Non-slip Tray | 12 | ASH | 682798881 | WAL | 682798882 | 240 |
| 8281 | Round PP Non-slip Tray | 12 | BRN | 682818881 | | | 240 |
| 8282 | Round PP Non-slip Tray | 12 | BRN | 682828881 | | | 240 |
| 8283 | Round PP Non-slip Tray | 12 | BRN | 682838881 | | | 240 |
| 8284 | Round PP Non-slip Tray | 12 | BRN | 682848881 | | | 240 |
| 8285 | Rectangle PP Non-slip Tray | 12 | BRN | 682858881 | | | 240 |
| 8286 | Rectangle PP Non-slip Tray | 12 | BRN | 682868881 | | | 240 |
| 8287 | Rectangle PP Non-slip Tray | 12 | BRN | 682878881 | | | 240 |
| 8288 | Rectangle PP Non-slip Tray | 12 | BRN | 682888881 | | | 240 |
| 8311 | Round Storage Container | 12 | STRAN | 683118881 | | | 200 |
| 8312 | Round Storage Container | 12 | STRAN | 683128881 | | | 200 |
| 8313 | Round Storage Container | 12 | STRAN | 683138881 | | | 200 |
| 8314 | Round Storage Container | 12 | STRAN | 683148881 | | | 200 |
| 8315 | Round Storage Container | 6 | STRAN | 683158881 | | | 200 |
| 8316 | Round Storage Container | 6 | STRAN | 683168881 | | | 200 |
| 8317 | Round Storage Container | 6 | STRAN | 683178881 | | | 200 |

| No. | Product Name | Pack | Color | Order Code | Color | Order Code | Page |
|------|---|------|-------|------------|-------|------------|------|
| 8318 | Round Storage Container with Bail | 6 | STRAN | 683188881 | | | 200 |
| 8321 | Round Storage Container | 12 | WHT | 683218881 | | | 200 |
| 8322 | Round Storage Container | 12 | WHT | 683228881 | | | 200 |
| 8323 | Round Storage Container | 12 | WHT | 683238881 | | | 200 |
| 8324 | Round Storage Container | 12 | WHT | 683248881 | | | 200 |
| 8325 | Round Storage Container | 6 | WHT | 683258881 | | | 200 |
| 8326 | Round Storage Container | 6 | WHT | 683268881 | | | 200 |
| 8327 | Round Storage Container | 6 | WHT | 683278881 | | | 200 |
| 8328 | Round Storage Container with Bail | 6 | WHT | 683288881 | | | 200 |
| 8331 | Lid for 8311/8312/8321/8322 | 12 | YEL | 683318881 | | | 200 |
| 8332 | Lid for 8313/8314/8323/8324 | 12 | YEL | 683328881 | NAT | 683328882 | 200 |
| 8333 | Lid for 8315/8316/8317/8325/8326/8327 | 6 | YEL | 683338881 | NAT | 683338882 | 200 |
| 8341 | Pitcher (Not BPA Free) | 6 | CLR | 683418881 | | | 255 |
| 8342 | Pitcher (Not BPA Free) | 6 | CLR | 683428881 | | | 255 |
| 8343 | Pitcher (Not BPA Free) | 6 | CLR | 683438881 | | | 255 |
| 8344 | Pitcher (Not BPA Free) | 6 | CLR | 683448881 | | | 255 |
| 8411 | Food Material Storage Bin | 1 | WHT | 684118881 | | | 184 |
| 8412 | Food Material Storage Bin | 1 | WHT | 684128881 | | | 184 |
| 8413 | Food Material Storage Bin | 1 | WHT | 684138881 | | | 184 |
| 8414 | Spoon | 6 | CLR | 684148881 | | | 184 |
| 8415 | Storage Bin Lid | 1 | WHT | 684158881 | | | 184 |
| 8416 | Storage Bin Lid | 1 | WHT | 684168881 | | | 184 |
| 8417 | Storage Bin Lid | 1 | WHT | 684178881 | | | 184 |
| 8418 | Shelf-type Raw Food Material Containers | 1 | WHT | 684188881 | | | 185 |
| 8419 | Shelf-type Raw Food Material Containers | 1 | WHT | 684198881 | | | 185 |
| 8420 | Shelf-type Raw Food Material Containers | 1 | WHT | 684208881 | | | 185 |
| 8421 | Fresh Fruits and Vegetables Storage Bin with a Lid and a Cart | 1 | WHT | 684218881 | | | 188 |
| 8422 | Fresh Fruits and Vegetables Storage Bin with a Lid and a Cart | 1 | WHT | 684228881 | | | 188 |
| 8431 | Ice Bucket | 6 | WHT | 684318881 | | | 188 |
| 8432 | Ice Bucket | 6 | WHT | 684328881 | | | 188 |
| 8433 | 0.5-Cup Measuring Spoon for 8418 | 12 | CLR | 684338881 | | | 185 |
| 8434 | 2-Cup Measuring Spoon for 8419, 8420 | 6 | CLR | 684348881 | | | 185 |
| 8441 | Condiment Dispenser with Three 0.9 L Inserts | 1 | BLA | 684418881 | | | 255 |
| 8442 | Condiment Dispenser with Four 0.7 L Inserts | 1 | BLA | 684428881 | | | 255 |
| 8443 | Condiment Dispenser with Six 0.5 L Inserts | 1 | BLA | 684438881 | | | 255 |
| 8451 | Cold Food Pan, Full Size | 6 | CLR | 684518881 | | | 192 |
| 8452 | Cold Food Pan, Full Size | 6 | CLR | 684528881 | | | 192 |
| 8453 | Cold Food Pan, Full Size | 6 | CLR | 684538881 | | | 192 |
| 8454 | Cold Food Pan, Full Size | 6 | CLR | 684548881 | | | 192 |
| 8455 | Cold Food Pan Cover with Handle, Full Size | 6 | CLR | 684558881 | | | 193 |
| 8456 | Cold Food Pan Cover with Handle and Notched, Full Size | 6 | CLR | 684568881 | | | 193 |
| 8457 | Cold Food Pan Flat Cover, Full Size | 6 | CLR | 684578881 | | | 194 |
| 8461 | Cold Food Pan, 1/2 Size | 6 | CLR | 684618881 | | | 192 |
| 8462 | Cold Food Pan, 1/2 Size | 6 | CLR | 684628881 | | | 192 |
| 8463 | Cold Food Pan, 1/2 Size | 6 | CLR | 684638881 | | | 192 |
| 8464 | Cold Food Pan, 1/2 Size | 6 | CLR | 684648881 | | | 192 |
| 8465 | Cold Food Pan Cover with Handle, 1/2 Size | 6 | CLR | 684658881 | | | 193 |
| 8466 | Cold Food Pan Cover with Handle and Notched, 1/2 Size | 6 | CLR | 684668881 | | | 193 |
| 8467 | Cold Food Pan Flat Cover, 1/2 Size | 6 | CLR | 684678881 | | | 194 |
| 8471 | Cold Food Pan, 1/3 Size | 6 | CLR | 684718881 | | | 192 |
| 8472 | Cold Food Pan, 1/3 Size | 6 | CLR | 684728881 | | | 192 |
| 8473 | Cold Food Pan, 1/3 Size | 6 | CLR | 684738881 | | | 192 |
| 8474 | Cold Food Pan, 1/3 Size | 6 | CLR | 684748881 | | | 192 |
| 8475 | Cold Food Pan Cover with Handle, 1/3 Size | 6 | CLR | 684758881 | | | 193 |
| 8476 | Cold Food Pan Cover with Handle and Notched, 1/3 Size | 6 | CLR | 684768881 | | | 193 |
| 8477 | Cold Food Pan Flat Cover, 1/3 Size | 6 | CLR | 684778881 | | | 194 |
| 8481 | Cold Food Pan, 1/4 Size | 6 | CLR | 684818881 | | | 192 |
| 8482 | Cold Food Pan, 1/4 Size | 6 | CLR | 684828881 | | | 192 |
| 8483 | Cold Food Pan, 1/4 Size | 6 | CLR | 684838881 | | | 192 |
| 8484 | Cold Food Pan Cover with Handle, 1/4 Size | 6 | CLR | 684848881 | | | 193 |
| 8485 | Cold Food Pan Cover with Handle and Notched, 1/4 Size | 6 | CLR | 684858881 | | | 193 |
| 8486 | Cold Food Pan Flat Cover, 1/4 Size | 6 | CLR | 684868881 | | | 194 |
| 8491 | Cold Food Pan, 1/6 Size | 6 | CLR | 684918881 | | | 192 |
| 8492 | Cold Food Pan, 1/6 Size | 6 | CLR | 684928881 | | | 192 |

PRODUCT INDEX

| No. | Product Name | Pack | Color | Order Code | Color | Order Code | Page |
|------|---|------|-------|------------|-------|------------|------|
| 8493 | Cold Food Pan, 1/6 Size | 6 | CLR | 684938881 | | | 192 |
| 8494 | Cold Food Pan Cover with Handle, 1/6 Size | 6 | CLR | 684948881 | | | 193 |
| 8495 | Cold Food Pan Cover with Handle and Notched, 1/6 Size | 6 | CLR | 684958881 | | | 193 |
| 8496 | Cold Food Pan Flat Cover, 1/6 Size | 6 | CLR | 684968881 | | | 194 |
| 8497 | Cold Food Pan, 1/9 Size | 6 | CLR | 684978881 | | | 192 |
| 8498 | Cold Food Pan, 1/9 Size | 6 | CLR | 684988881 | | | 192 |
| 8499 | Cold Food Pan Flat Cover, 1/9 Size | 6 | CLR | 684998881 | | | 194 |
| 8501 | Cold Drain Tray, Full Size | 6 | CLR | 685018881 | | | 194 |
| 8502 | Cold Drain Tray, 1/2 Size | 6 | CLR | 685028881 | | | 194 |
| 8503 | Cold Drain Tray, 1/3 Size | 6 | CLR | 685038881 | | | 194 |
| 8504 | Cold Drain Tray, 1/4 Size | 6 | CLR | 685048881 | | | 194 |
| 8505 | Cold Drain Tray, 1/6 Size | 6 | CLR | 685058881 | | | 194 |
| 8506 | Hot Drain Tray, Full Size | 6 | AMBR | 685068881 | | | 194 |
| 8507 | Hot Drain Tray, 1/2 Size | 6 | AMBR | 685078881 | | | 194 |
| 8508 | Hot Drain Tray, 1/3 Size | 6 | AMBR | 685088881 | | | 194 |
| 8509 | Hot Drain Tray, 1/4 Size | 6 | AMBR | 685098881 | | | 194 |
| 8510 | Hot Drain Tray, 1/6 Size | 6 | AMBR | 685108881 | | | 194 |
| 8511 | Scraper | 36 | WHT | 685118881 | | | 242 |
| 8512 | Scraper | 36 | WHT | 685128881 | | | 242 |
| 8513 | Scraper | 36 | WHT | 685138881 | | | 242 |
| 8514 | Ice Scraper | 36 | WHT | 685148881 | | | 242 |
| 8515 | Spoon-shaped Scraper | 36 | WHT | 685158881 | | | 242 |
| 8516 | Spoon-shaped Scraper | 36 | WHT | 685168881 | | | 242 |
| 8517 | Spoon-shaped Scraper | 36 | WHT | 685178881 | | | 242 |
| 8520 | Chopping Board | 6 | RED | 685208881 | GRN | 685208884 | 243 |
| | | | YEL | 685208882 | BRN | 685208885 | |
| | | | BLUE | 685208883 | WHT | 685208886 | |
| 8521 | Chopping Board | 6 | RED | 685218881 | GRN | 685218884 | 243 |
| | | | YEL | 685218882 | BRN | 685218885 | |
| | | | BLUE | 685218883 | WHT | 685218886 | |
| 8522 | The Chopping Board Set (6 colors) | 1 | | 685228881 | | | 243 |
| 8523 | Chopping Board Holder | 1 | MSILV | 685238881 | | | 243 |
| 8524 | Chopping Board | 6 | RED | 685248881 | GRN | 685248884 | 243 |
| | | | YEL | 685248882 | BRN | 685248885 | |
| | | | BLUE | 685248883 | WHT | 685248886 | |
| 8525 | Chopping Board | 6 | RED | 685258881 | GRN | 685258884 | 243 |
| | | | YEL | 685258882 | BRN | 685258885 | |
| | | | BLUE | 685258883 | WHT | 685258886 | |
| 8526 | Chopping Board | 6 | RED | 685268881 | GRN | 685268884 | 243 |
| | | | YEL | 685268882 | BRN | 685268885 | |
| | | | BLUE | 685268883 | WHT | 685268886 | |
| 8527 | Chopping Board | 6 | RED | 685278881 | GRN | 685278884 | 243 |
| | | | YEL | 685278882 | BRN | 685278885 | |
| | | | BLUE | 685278883 | WHT | 685278886 | |
| 8528 | Chopping Board | 6 | RED | 685288881 | GRN | 685288884 | 243 |
| | | | YEL | 685288882 | BRN | 685288885 | |
| | | | BLUE | 685288883 | WHT | 685288886 | |
| 8529 | Chopping Board Holder | 1 | BLA | 685298881 | | | 243 |
| 8613 | Food Storage Rack / Cart | 1 | OWHT | 686138881 | BLA | 686138882 | 230 |
| 8614 | Food Storage Rack / Cart | 1 | OWHT | 686148881 | BLA | 686148882 | 230 |
| 8615 | Food Storage Rack/Cart | 1 | OWHT | 686158881 | BLA | 686158882 | 230 |
| 8621 | Food Storage Rack | 1 | OWHT | 686218881 | BLA | 686218882 | 230 |
| 8622 | Food Storage Rack | 1 | OWHT | 686228881 | BLA | 686228882 | 230 |
| 8651 | Adjustable Tray&Dish Cart | 1 | DBRN | 686518881 | BLA | 686518883 | 231 |
| | | | SGRAY | 686518882 | | | |
| 8652 | Separation Column | 2 | DBRN | 686528881 | BLA | 686528883 | 231 |
| | | | SGRAY | 686528882 | | | |
| 8653 | Cover | 2 | CLR | 686538881 | | | 231 |
| 8701 | Cold Drink Coolbox | 1 | RED | 687018881 | | | 219 |
| 8702 | Cold Drink Coolbox | 1 | RED | 687028881 | | | 219 |
| 8703 | Cold Drink Coolbox | 1 | RED | 687038881 | | | 219 |
| 8711 | Insulated Box | 1 | RED | 687118881 | | | 218 |
| 8712 | Insulated Box | 1 | RED | 687128881 | | | 218 |
| 8713 | Insulated Box | 1 | RED | 687138881 | | | 218 |

| No. | Product Name | Pack | Color | Order Code | Color | Order Code | Page |
|------|---|------|-------|------------|-------|------------|------|
| 8714 | Insulated Box | 1 | RED | 687148881 | | | 218 |
| 8715 | Pull Rod Type Insulated Box | 1 | RED | 687158881 | | | 218 |
| 8721 | Insulated Bottle | 1 | RED | 687218881 | | | 219 |
| 8731 | GN 1/1 Cold Food Pan - 65mm | 6 | CLR | 687318881 | | | 197 |
| 8732 | GN 1/1 Cold Food Pan - 100mm | 6 | CLR | 687328881 | | | 197 |
| 8733 | GN 1/1 Cold Food Pan - 150mm | 6 | CLR | 687338881 | | | 197 |
| 8734 | GN 1/1 Cold Food Pan - 200mm | 6 | CLR | 687348881 | | | 197 |
| 8735 | GN 1/1 Lids with Handle | 6 | CLR | 687358881 | | | 198 |
| 8736 | GN 1/1 Lids with Entry and Handle | 6 | CLR | 687368881 | | | 198 |
| 8737 | GN 1/1 Flat Lid | 6 | CLR | 687378881 | | | 199 |
| 8741 | GN 1/2 Cold Food Pan - 65mm | 6 | CLR | 687418881 | | | 197 |
| 8742 | GN 1/2 Cold Food Pan - 100mm | 6 | CLR | 687428881 | | | 197 |
| 8743 | GN 1/2 Cold Food Pan - 150mm | 6 | CLR | 687438881 | | | 197 |
| 8744 | GN 1/2 Cold Food Pan - 200mm | 6 | CLR | 687448881 | | | 197 |
| 8745 | GN 1/2 Lids with Handle | 6 | CLR | 687458881 | | | 198 |
| 8746 | GN 1/2 Lids with Entry and Handle | 6 | CLR | 687468881 | | | 198 |
| 8747 | GN 1/2 Flat Lid | 6 | CLR | 687478881 | | | 199 |
| 8751 | GN 1/3 Cold Food Pan - 65mm | 6 | CLR | 687518881 | | | 197 |
| 8752 | GN 1/3 Cold Food Pan - 100mm | 6 | CLR | 687528881 | | | 197 |
| 8753 | GN 1/3 Cold Food Pan - 150mm | 6 | CLR | 687538881 | | | 197 |
| 8754 | GN 1/3 Cold Food Pan - 200mm | 6 | CLR | 687548881 | | | 197 |
| 8755 | GN 1/3 Lids with Handle | 6 | CLR | 687558881 | | | 198 |
| 8756 | GN 1/3 Lids with Entry and Handle | 6 | CLR | 687568881 | | | 198 |
| 8757 | GN 1/3 Flat Lid | 6 | CLR | 687578881 | | | 199 |
| 8761 | GN 1/4 Cold Food Pan - 65mm | 6 | CLR | 687618881 | | | 197 |
| 8762 | GN 1/4 Cold Food Pan - 100mm | 6 | CLR | 687628881 | | | 197 |
| 8763 | GN 1/4 Cold Food Pan - 150mm | 6 | CLR | 687638881 | | | 197 |
| 8764 | GN 1/4 Lids with Handle | 6 | CLR | 687648881 | | | 198 |
| 8765 | GN 1/4 Lids with Entry and Handle | 6 | CLR | 687658881 | | | 198 |
| 8766 | GN 1/4 Flat Lid | 6 | CLR | 687668881 | | | 199 |
| 8771 | GN 1/6 Cold Food Pan - 65mm | 6 | CLR | 687718881 | | | 197 |
| 8772 | GN 1/6 Cold Food Pan - 100mm | 6 | CLR | 687728881 | | | 197 |
| 8773 | GN 1/6 Cold Food Pan - 150mm | 6 | CLR | 687738881 | | | 197 |
| 8774 | GN 1/6 Lids with Handle | 6 | CLR | 687748881 | | | 198 |
| 8775 | GN 1/6 Lids with Entry and Handle | 6 | CLR | 687758881 | | | 198 |
| 8776 | GN 1/6 Flat Lid | 6 | CLR | 687768881 | | | 199 |
| 8781 | GN 1/9 Cold Food Pan - 65mm | 6 | CLR | 687818881 | | | 197 |
| 8782 | GN 1/9 Cold Food Pan - 100mm | 6 | CLR | 687828881 | | | 197 |
| 8783 | GN 1/9 Flat Lid | 6 | CLR | 687838881 | | | 199 |
| 8791 | GN 1/1 Drain Trays | 6 | CLR | 687918881 | | | 199 |
| 8792 | GN 1/2 Drain Trays | 6 | CLR | 687928881 | | | 199 |
| 8793 | GN 1/3 Drain Trays | 6 | CLR | 687938881 | | | 199 |
| 8794 | GN 1/4 Drain Trays | 6 | CLR | 687948881 | | | 199 |
| 8795 | GN 1/6 Drain Trays | 6 | CLR | 687958881 | | | 199 |
| 8811 | Hot Food Pan, Full Size | 6 | AMBR | 688118881 | BLA | 688118882 | 192 |
| 8812 | Hot Food Pan, Full Size | 6 | AMBR | 688128881 | BLA | 688128882 | 192 |
| 8813 | Hot Food Pan, Full Size | 6 | AMBR | 688138881 | BLA | 688138882 | 192 |
| 8814 | Hot Food Pan Cover with Handle, Full Size | 6 | AMBR | 688148881 | | | 193 |
| 8815 | Hot Food Pan Cover with Handle and Notched, Full Size | 6 | AMBR | 688158881 | | | 193 |
| 8816 | Hot Food Pan Flat Cover, Full Size | 6 | AMBR | 688168881 | | | 194 |
| 8821 | Hot Food Pan, 1/2 Size | 6 | AMBR | 688218881 | BLA | 688218882 | 192 |
| 8822 | Hot Food Pan, 1/2 Size | 6 | AMBR | 688228881 | BLA | 688228882 | 192 |
| 8823 | Hot Food Pan, 1/2 Size | 6 | AMBR | 688238881 | BLA | 688238882 | 192 |
| 8824 | Hot Food Pan Cover with Handle, 1/2 Size | 6 | AMBR | 688248881 | | | 193 |
| 8825 | Hot Food Pan Cover with Handle and Notched, 1/2 Size | 6 | AMBR | 688258881 | | | 193 |
| 8826 | Hot Food Pan Flat Cover, 1/2 Size | 6 | AMBR | 688268881 | | | 194 |
| 8831 | Hot Food Pan, 1/3 Size | 6 | AMBR | 688318881 | BLA | 688318882 | 192 |
| 8832 | Hot Food Pan, 1/3 Size | 6 | AMBR | 688328881 | BLA | 688328882 | 192 |
| 8833 | Hot Food Pan, 1/3 Size | 6 | AMBR | 688338881 | BLA | 688338882 | 192 |
| 8834 | Hot Food Pan Cover with Handle, 1/3 Size | 6 | AMBR | 688348881 | | | 193 |
| 8835 | Hot Food Pan Cover with Handle and Notched, 1/3 Size | 6 | AMBR | 688358881 | | | 193 |
| 8836 | Hot Food Pan Flat Cover, 1/3 Size | 6 | AMBR | 688368881 | | | 194 |
| 8841 | Hot Food Pan, 1/4 Size | 6 | AMBR | 688418881 | BLA | 688418882 | 192 |
| 8842 | Hot Food Pan, 1/4 Size | 6 | AMBR | 688428881 | BLA | 688428882 | 192 |

PRODUCT INDEX

| No. | Product Name | Pack | Color | Order Code | Color | Order Code | Page |
|------|--|------|-------|------------|-------|------------|------|
| 8843 | Hot Food Pan, 1/4 Size | 6 | AMBR | 688438881 | BLA | 688438882 | 192 |
| 8844 | Hot Food Pan Cover with Handle, 1/4 Size | 6 | AMBR | 688448881 | | | 193 |
| 8845 | Hot Food Pan Cover with Handle and Notched, 1/4 Size | 6 | AMBR | 688458881 | | | 193 |
| 8846 | Hot Food Pan Flat Cover, 1/4 Size | 6 | AMBR | 688468881 | | | 194 |
| 8851 | Hot Food Pan, 1/6 Size | 6 | AMBR | 688518881 | BLA | 688518882 | 192 |
| 8852 | Hot Food Pan, 1/6 Size | 6 | AMBR | 688528881 | BLA | 688528882 | 192 |
| 8853 | Hot Food Pan, 1/6 Size | 6 | AMBR | 688538881 | BLA | 688538882 | 192 |
| 8854 | Hot Food Pan Cover with Handle, 1/6 Size | 6 | AMBR | 688548881 | | | 193 |
| 8855 | Hot Food Pan Cover with Handle and Notched, 1/6 Size | 6 | AMBR | 688558881 | | | 193 |
| 8856 | Hot Food Pan Flat Cover, 1/6 Size | 6 | AMBR | 688568881 | | | 194 |
| 8861 | Hot Food Pan, 1/9 Size | 6 | AMBR | 688618881 | BLA | 688618882 | 192 |
| 8862 | Hot Food Pan, 1/9 Size | 6 | AMBR | 688628881 | BLA | 688628882 | 192 |
| 8863 | Hot Food Pan Flat Cover, 1/9 Size | 6 | AMBR | 688638881 | | | 194 |
| 8870 | GN1/2 EXCEBOX® 25.7cm Height | 1 | BLA | 688708881 | | | 227 |
| 8871 | GN1/2 EXCEBOX® 31.6cm Height | 1 | BLA | 688718881 | | | 227 |
| 8872 | GN1/2 EXCEBOX® with Carrying Handle | 1 | BLA | 688728881 | | | 227 |
| 8873 | GN1/1 EXCEBOX® 25.7cm Height | 1 | BLA | 688738881 | | | 227 |
| 8874 | GN1/1 EXCEBOX® 31.6cm Height | 1 | BLA | 688748881 | | | 227 |
| 8875 | GN1/1 EXCEBOX® Stackable | 1 | BLA | 688758881 | | | 227 |
| 8876 | GN1/1 EXCEBOX® with Ergonomic Handles | 1 | BLA | 688768881 | | | 227 |
| 8877 | 6040 EXCEBOX® 27.0cm Height | 1 | BLA | 688778881 | | | 227 |
| 8878 | 6040 EXCEBOX® 37.0cm Height | 1 | BLA | 688788881 | | | 227 |
| 8879 | Front-Loading EXCEBOX® 47.5cm Height | 1 | BLA | 688798881 | | | 225 |
| 8880 | Front-Loading EXCEBOX® 62.5cm Height | 1 | BLA | 688808881 | | | 225 |
| 8881 | Front-Loading EXCEBOX® without Rail | 1 | BLA | 688818881 | | | 225 |
| 8882 | Front-Loading EXCEBOX® with 6 Rails | 1 | BLA | 688828881 | | | 225 |
| 8883 | Front-Loading EXCEBOX® with 9 Rails | 1 | BLA | 688838881 | | | 225 |
| 8884 | Plastic Labels | 1 | N/A | 688848881 | | | 228 |
| 8885 | GN1/2 Cooler | 1 | BLUE | 688858881 | | | 228 |
| 8886 | GN1/1 Cooler | 1 | BLUE | 688868881 | | | 228 |
| 8887 | GN1/1 Warmer | 1 | RED | 688878881 | | | 228 |
| 8888 | Totes Trolley | 1 | BLA | 688888881 | | | 228 |
| 8889 | Totes Trolley | 1 | BLA | 688898881 | | | 228 |
| 8890 | Adjustable Rail Kit | 1 | SS | 688908881 | | | 228 |
| 8891 | GN1/2 Lid for Top-loading Excebox® | 6 | BLA | 688918881 | RED | 688918882 | 228 |
| | | | YEL | 688918883 | BLUE | 688918884 | |
| | | | GRN | 688918885 | ORA | 688918886 | |
| 8892 | GN 1/1 Lid for Top-loading Excebox® | 6 | BLA | 688928881 | RED | 688928882 | 228 |
| | | | YEL | 688928883 | BLUE | 688928884 | |
| | | | GRN | 688928885 | ORA | 688928886 | |
| 8911 | GN 1/1 Cold Food Pan-65mm | 6 | CLR | 689118881 | | | 197 |
| 8912 | GN 1/1 Cold Food Pan-100mm | 6 | CLR | 689128881 | | | 197 |
| 8913 | GN 1/1 Cold Food Pan-150mm | 6 | CLR | 689138881 | | | 197 |
| 8914 | GN 1/1 Cold Food Pan-200mm | 6 | CLR | 689148881 | | | 197 |
| 8915 | GN 1/1 Lids with Handle | 6 | CLR | 689158881 | | | 198 |
| 8916 | GN 1/1 Lids with Entry and Handle | 6 | CLR | 689168881 | | | 198 |
| 8917 | GN 1/1 Flat Lid | 6 | CLR | 689178881 | | | 199 |
| 8921 | GN 1/2 Cold Food Pan-65mm | 6 | CLR | 689218881 | | | 197 |
| 8922 | GN 1/2 Cold Food Pan-100mm | 6 | CLR | 689228881 | | | 197 |
| 8923 | GN 1/2 Cold Food Pan-150mm | 6 | CLR | 689238881 | | | 197 |
| 8924 | GN 1/2 Cold Food Pan-200mm | 6 | CLR | 689248881 | | | 197 |
| 8925 | GN 1/2 Lids with Handle | 6 | CLR | 689258881 | | | 198 |
| 8926 | GN 1/2 Lids with Entry and Handle | 6 | CLR | 689268881 | | | 198 |
| 8927 | GN 1/2 Flat Lid | 6 | CLR | 689278881 | | | 199 |
| 8931 | GN 1/3 Cold Food Pan-65mm | 6 | CLR | 689318881 | | | 197 |
| 8932 | GN 1/3 Cold Food Pan-100mm | 6 | CLR | 689328881 | | | 197 |
| 8933 | GN 1/3 Cold Food Pan-150mm | 6 | CLR | 689338881 | | | 197 |
| 8934 | GN 1/3 Cold Food Pan-200mm | 6 | CLR | 689348881 | | | 197 |
| 8935 | GN 1/3 Lids with Handle | 6 | CLR | 689358881 | | | 198 |
| 8936 | GN 1/3 Lids with Entry and Handle | 6 | CLR | 689368881 | | | 198 |
| 8937 | GN 1/3 Flat Lid | 6 | CLR | 689378881 | | | 199 |
| 8941 | GN 1/4 Cold Food Pan-65mm | 6 | CLR | 689418881 | | | 197 |
| 8942 | GN 1/4 Cold Food Pan-100mm | 6 | CLR | 689428881 | | | 197 |
| 8943 | GN 1/4 Cold Food Pan-150mm | 6 | CLR | 689438881 | | | 197 |

| No. | Product Name | Pack | Color | Order Code | Color | Order Code | Page |
|------|---|------|------------|------------------------|-------|------------|------|
| 8944 | GN 1/4 Lids with Handle | 6 | CLR | 689448881 | | | 198 |
| 8945 | GN 1/4 Lids with Entry and Handle | 6 | CLR | 689458881 | | | 198 |
| 8946 | GN 1/4 Flat Lid | 6 | CLR | 689468881 | | | 199 |
| 8951 | GN 1/6 Cold Food Pan-65mm | 6 | CLR | 689518881 | | | 197 |
| 8952 | GN 1/6 Cold Food Pan-100mm | 6 | CLR | 689528881 | | | 197 |
| 8953 | GN 1/6 Cold Food Pan-150mm | 6 | CLR | 689538881 | | | 197 |
| 8954 | GN 1/6 Lids with Handle | 6 | CLR | 689548881 | | | 198 |
| 8955 | GN 1/6 Lids with Entry and Handle | 6 | CLR | 689558881 | | | 198 |
| 8956 | GN 1/6 Flat Lid | 6 | CLR | 689568881 | | | 199 |
| 8961 | GN 1/9 Cold Food Pan-65mm | 6 | CLR | 689618881 | | | 197 |
| 8962 | GN 1/9 Cold Food Pan-100mm | 6 | CLR | 689628881 | | | 197 |
| 8963 | GN 1/9 Flat Lid | 6 | CLR | 689638881 | | | 199 |
| 8971 | GN 1/1 Drain Trays | 6 | CLR | 689718881 | | | 199 |
| 8972 | GN 1/2 Drain Trays | 6 | CLR | 689728881 | | | 199 |
| 8973 | GN 1/3 Drain Trays | 6 | CLR | 689738881 | | | 199 |
| 8974 | GN 1/4 Drain Trays | 6 | CLR | 689748881 | | | 199 |
| 8975 | GN 1/6 Drain Trays | 6 | CLR | 689758881 | | | 199 |
| 9000 | Cupcomb® Half Size Open Extender | 12 | LGRAY | 690008881 | | | 250 |
| 9001 | Cupcomb® Half Size Cover | 1 | WHT | 690018888 | | | 251 |
| 9002 | Cupcomb® 8 Compartment Half Size Flatware Basket | 6 | LGRAY | 690028888 | | | 250 |
| 9003 | Cupcomb® 8 Compartment Half Size Flatware Basket with Handle | 6 | LGRAY | 690038881 | | | 250 |
| 9008 | Cupcomb® Full Size Cover | 1 | WHT RED | 690088881 690088882 | GRN | 690088885 | 251 |
| 9009 | Cupcomb® Full Size Open Extender | 12 | LGRAY | 690098881 | | | 250 |
| 9080 | Cupcomb® Half Size Glass Racks - 8 Compartment - Base Rack | 6 | LGRAY | 690808881 | SGRN | 690808882 | 247 |
| 9081 | Cupcomb® Half Size Glass Racks - 8 Compartment - Base Rack with 1 Extender | 5 | N/A | 690818881 | | | 247 |
| 9082 | Cupcomb® Half Size Glass Racks - 8 Compartment - Base Rack with 2 Extender | 4 | N/A | 690828881 | | | 247 |
| 9083 | Cupcomb® Half Size Glass Racks - 8 Compartment - Base Rack with 3 Extender | 3 | N/A | 690838881 | | | 247 |
| 9084 | Cupcomb® Half Size Glass Racks - 8 Compartment - Base Rack with 4 Extender | 2 | N/A | 690848881 | | | 247 |
| 9085 | Cupcomb® Half Size Glass Racks - 8 Compartment - Base Rack with 5 Extender | 2 | N/A | 690858881 | | | 247 |
| 9086 | Cupcomb® Half Size Glass Racks - 8 Compartment - Base Rack with 6 Extender | 2 | N/A | 690868881 | | | 247 |
| 9089 | Cupcomb® 8 Compartment Half Size Extender | 12 | LGRAY | 690898881 | | | 250 |
| 9090 | Cupcomb® Full Size Glass Racks - 9 Compartment - Base Rack | 6 | LGRAY | 690908881 | RBRN | 690908882 | 245 |
| 9091 | Cupcomb® Full Size Glass Racks - 9 Compartment - Base Rack with 1 Extender | 5 | N/A | 690918881 | | | 245 |
| 9092 | Cupcomb® Full Size Glass Racks - 9 Compartment - Base Rack with 2 Extender | 4 | N/A | 690928881 | | | 245 |
| 9093 | Cupcomb® Full Size Glass Racks - 9 Compartment - Base Rack with 3 Extender | 3 | N/A | 690938881 | | | 245 |
| 9094 | Cupcomb® Full Size Glass Racks - 9 Compartment - Base Rack with 4 Extender | 2 | N/A | 690948881 | | | 245 |
| 9095 | Cupcomb® Full Size Glass Racks - 9 Compartment - Base Rack with 5 Extender | 2 | N/A | 690958881 | | | 245 |
| 9096 | Cupcomb® Full Size Glass Racks - 9 Compartment - Base Rack with 6 Extender | 2 | N/A | 690968881 | | | 245 |
| 9099 | Cupcomb® 9 Compartment Full Size Extender | 12 | LGRAY | 690998881 | | | 250 |
| 9100 | Cupcomb® Half Size Glass Racks - 10 Compartment - Base Rack | 6 | LGRAY | 691008881 | IND | 691008882 | 247 |
| 9101 | Cupcomb® Half Size Glass Racks - 10 Compartment - Base Rack with 1 Extender | 5 | N/A | 691018881 | | | 247 |
| 9102 | Cupcomb® Half Size Glass Racks - 10 Compartment - Base Rack with 2 Extender | 4 | N/A | 691028881 | | | 247 |
| 9103 | Cupcomb® Half Size Glass Racks - 10 Compartment - Base Rack with 3 Extender | 3 | N/A | 691038881 | | | 247 |
| 9104 | Cupcomb® Half Size Glass Racks - 10 Compartment - Base Rack with 4 Extender | 2 | N/A | 691048881 | | | 247 |
| 9105 | Cupcomb® Half Size Glass Racks - 10 Compartment - Base Rack with 5 Extender | 2 | N/A | 691058881 | | | 247 |
| 9106 | Cupcomb® Half Size Glass Racks - 10 Compartment - Base Rack with 6 Extender | 2 | N/A | 691068881 | | | 247 |
| 9109 | Cupcomb® 10 Compartment Half Size Extender | 12 | LGRAY | 691098881 | | | 250 |

PRODUCT INDEX

| No. | Product Name | Pack | Color | Order Code | Color | Order Code | Page |
|------|---|------|-------|------------|-------|------------|------|
| 9160 | Cupcomb® Full Size Glass Racks - 16 Compartment - Base Rack | 6 | LGRAY | 691608881 | SGRN | 691608882 | 245 |
| 9161 | Cupcomb® Full Size Glass Racks - 16 Compartment - Base Rack with 1 Extender | 5 | N/A | 691618881 | | | 245 |
| 9162 | Cupcomb® Full Size Glass Racks - 16 Compartment - Base Rack with 2 Extender | 4 | N/A | 691628881 | | | 245 |
| 9163 | Cupcomb® Full Size Glass Racks - 16 Compartment - Base Rack with 3 Extender | 3 | N/A | 691638881 | | | 245 |
| 9164 | Cupcomb® Full Size Glass Racks - 16 Compartment - Base Rack with 4 Extender | 2 | N/A | 691648881 | | | 245 |
| 9165 | Cupcomb® Full Size Glass Racks - 16 Compartment - Base Rack with 5 Extender | 2 | N/A | 691658881 | | | 245 |
| 9166 | Cupcomb® Full Size Glass Racks - 16 Compartment - Base Rack with 6 Extender | 2 | N/A | 691668881 | | | 245 |
| 9169 | Cupcomb® 16 Compartment Full Size Extender | 12 | LGRAY | 691698881 | | | 250 |
| 9170 | Cupcomb® Half Size Glass Racks - 17 Compartment - Base Rack | 6 | LGRAY | 691708881 | LRED | 691708882 | 247 |
| 9171 | Cupcomb® Half Size Glass Racks - 17 Compartment - Base Rack with 1 Extender | 5 | N/A | 691718881 | | | 247 |
| 9172 | Cupcomb® Half Size Glass Racks - 17 Compartment - Base Rack with 2 Extender | 4 | N/A | 691728881 | | | 247 |
| 9173 | Cupcomb® Half Size Glass Racks - 17 Compartment - Base Rack with 3 Extender | 3 | N/A | 691738881 | | | 247 |
| 9174 | Cupcomb® Half Size Glass Racks - 17 Compartment - Base Rack with 4 Extender | 2 | N/A | 691748881 | | | 247 |
| 9175 | Cupcomb® Half Size Glass Racks - 17 Compartment - Base Rack with 5 Extender | 2 | N/A | 691758881 | | | 247 |
| 9176 | Cupcomb® Half Size Glass Racks - 17 Compartment - Base Rack with 6 Extender | 2 | N/A | 691768881 | | | 247 |
| 9179 | Cupcomb® 17 Compartment Half Size Extender | 12 | LGRAY | 691798881 | | | 250 |
| 9200 | Cupcomb® Full Size Glass Racks - 20 Compartment - Base Rack | 6 | LGRAY | 692008881 | GRAY | 692008882 | 245 |
| 9201 | Cupcomb® Full Size Glass Racks - 20 Compartment - Base Rack with 1 Extender | 5 | N/A | 692018881 | | | 245 |
| 9202 | Cupcomb® Full Size Glass Racks - 20 Compartment - Base Rack with 2 Extender | 4 | N/A | 692028881 | | | 245 |
| 9203 | Cupcomb® Full Size Glass Racks - 20 Compartment - Base Rack with 3 Extender | 3 | N/A | 692038881 | | | 245 |
| 9204 | Cupcomb® Full Size Glass Racks - 20 Compartment - Base Rack with 4 Extender | 2 | N/A | 692048881 | | | 245 |
| 9205 | Cupcomb® Full Size Glass Racks - 20 Compartment - Base Rack with 5 Extender | 2 | N/A | 692058881 | | | 245 |
| 9206 | Cupcomb® Full Size Glass Racks - 20 Compartment - Base Rack with 6 Extender | 2 | N/A | 692068881 | | | 245 |
| 9209 | Cupcomb® 20 Compartment Full Size Extender | 12 | LGRAY | 692098881 | | | 250 |
| 9250 | Cupcomb® Full Size Glass Racks - 25 Compartment - Base Rack | 6 | LGRAY | 692508881 | IND | 692508882 | 246 |
| 9251 | Cupcomb® Full Size Glass Racks - 25 Compartment - Base Rack with 1 Extender | 5 | N/A | 692518881 | | | 246 |
| 9252 | Cupcomb® Full Size Glass Racks - 25 Compartment - Base Rack with 2 Extender | 4 | N/A | 692528881 | | | 246 |
| 9253 | Cupcomb® Full Size Glass Racks - 25 Compartment - Base Rack with 3 Extender | 3 | N/A | 692538881 | | | 246 |
| 9254 | Cupcomb® Full Size Glass Racks - 25 Compartment - Base Rack with 4 Extender | 2 | N/A | 692548881 | | | 246 |
| 9255 | Cupcomb® Full Size Glass Racks - 25 Compartment - Base Rack with 5 Extender | 2 | N/A | 692558881 | | | 246 |
| 9256 | Cupcomb® Full Size Glass Racks - 25 Compartment - Base Rack with 6 Extender | 2 | N/A | 692568881 | | | 246 |
| 9259 | Cupcomb® 25 Compartment Full Size Extender | 12 | LGRAY | 692598881 | | | 250 |
| 9300 | Cupcomb® Full Size Glass Racks - 30 Compartment - Base Rack | 6 | LGRAY | 693008881 | YEL | 693008882 | 246 |
| 9301 | Cupcomb® Full Size Glass Racks - 30 Compartment - Base Rack with 1 Extender | 5 | N/A | 693018881 | | | 246 |
| 9302 | Cupcomb® Full Size Glass Racks - 30 Compartment - Base Rack with 2 Extender | 4 | N/A | 693028881 | | | 246 |
| 9303 | Cupcomb® Full Size Glass Racks - 30 Compartment - Base Rack with 3 Extender | 3 | N/A | 693038881 | | | 246 |
| 9304 | Cupcomb® Full Size Glass Racks - 30 Compartment - Base Rack with 4 Extender | 2 | N/A | 693048881 | | | 246 |
| 9305 | Cupcomb® Full Size Glass Racks - 30 Compartment - Base Rack with 5 Extender | 2 | N/A | 693058881 | | | 246 |

| No. | Product Name | Pack | Color | Order Code | Color | Order Code | Page |
|------|---|------|-------|------------|-------|------------|------|
| 9306 | Cupcomb® Full Size Glass Racks - 30 Compartment - Base Rack with 6 Extender | 2 | N/A | 693068881 | | | 246 |
| 9309 | Cupcomb® 30 Compartment Full Size Extender | 12 | LGRAY | 693098881 | | | 250 |
| 9360 | Cupcomb® Full Size Glass Racks - 36 Compartment - Base Rack | 6 | LGRAY | 693608881 | LRED | 693608882 | 246 |
| 9361 | Cupcomb® Full Size Glass Racks - 36 Compartment - Base Rack with 1 Extender | 5 | N/A | 693618881 | | | 246 |
| 9362 | Cupcomb® Full Size Glass Racks - 36 Compartment - Base Rack with 2 Extender | 4 | N/A | 693628881 | | | 246 |
| 9363 | Cupcomb® Full Size Glass Racks - 36 Compartment - Base Rack with 3 Extender | 3 | N/A | 693638881 | | | 246 |
| 9364 | Cupcomb® Full Size Glass Racks - 36 Compartment - Base Rack with 4 Extender | 2 | N/A | 693648881 | | | 246 |
| 9365 | Cupcomb® Full Size Glass Racks - 36 Compartment - Base Rack with 5 Extender | 2 | N/A | 693658881 | | | 246 |
| 9366 | Cupcomb® Full Size Glass Racks - 36 Compartment - Base Rack with 6 Extender | 2 | N/A | 693668881 | | | 246 |
| 9369 | Cupcomb® 36 Compartment Full Size Extender | 12 | LGRAY | 693698881 | | | 250 |
| 9490 | Cupcomb® Full Size Glass Racks - 49 Compartment - Base Rack | 6 | LGRAY | 694908881 | LBEIG | 694908882 | 246 |
| 9491 | Cupcomb® Full Size Glass Racks - 49 Compartment - Base Rack with 1 Extender | 5 | N/A | 694918881 | | | 246 |
| 9492 | Cupcomb® Full Size Glass Racks - 49 Compartment - Base Rack with 2 Extender | 4 | N/A | 694928881 | | | 246 |
| 9493 | Cupcomb® Full Size Glass Racks - 49 Compartment - Base Rack with 3 Extender | 3 | N/A | 694938881 | | | 246 |
| 9494 | Cupcomb® Full Size Glass Racks - 49 Compartment - Base Rack with 4 Extender | 2 | N/A | 694948881 | | | 246 |
| 9495 | Cupcomb® Full Size Glass Racks - 49 Compartment - Base Rack with 5 Extender | 2 | N/A | 694958881 | | | 246 |
| 9496 | Cupcomb® Full Size Glass Racks - 49 Compartment - Base Rack with 6 Extender | 2 | N/A | 694968881 | | | 246 |
| 9499 | Cupcomb® 49 Compartment Full Size Extender | 12 | LGRAY | 694998881 | | | 250 |
| 9600 | Cupcomb® Base Rack - Full Size - Base Rack | 6 | LGRAY | 696008881 | | | 248 |
| 9601 | Cupcomb® Base Rack - Full Size - Base Rack with 1 Extender | 5 | LGRAY | 696018881 | | | 248 |
| 9602 | Cupcomb® Base Rack - Full Size - Base Rack with 2 Extender | 4 | LGRAY | 696028881 | | | 248 |
| 9603 | Cupcomb® Base Rack - Full Size - Base Rack with 3 Extender | 3 | LGRAY | 696038881 | | | 248 |
| 9610 | Cupcomb® Base Rack - Half Size - Base Rack | 6 | LGRAY | 696108881 | | | 248 |
| 9611 | Cupcomb® Base Rack - Half Size - Base Rack with 1 Extender | 5 | LGRAY | 696118881 | | | 248 |
| 9612 | Cupcomb® Base Rack - Half Size - Base Rack with 2 Extender | 4 | LGRAY | 696128881 | | | 248 |
| 9613 | Cupcomb® Base Rack - Half Size - Base Rack with 3 Extender | 3 | LGRAY | 696138881 | | | 248 |
| 9620 | Cupcomb® 5 × 9 Peg Rack | 6 | LGRAY | 696208881 | | | 249 |
| 9621 | Cupcomb® 5 × 9 Peg Rack with 1 Extender | 5 | LGRAY | 696218881 | | | 249 |
| 9630 | Cupcomb® 9 × 9 Peg Rack | 6 | LGRAY | 696308881 | | | 249 |
| 9631 | Cupcomb® 9 × 9 Peg Rack with 1 Extender | 5 | LGRAY | 696318881 | | | 249 |
| 9640 | Cupcomb® Open End Tray Rack | 6 | LGRAY | 696408881 | | | 249 |
| 9650 | Cupcomb® Flatware Rack - Full Size | 6 | LGRAY | 696508881 | | | 248 |
| 9651 | Cupcomb® Flatware Rack - Half Size | 6 | LGRAY | 696518881 | | | 248 |
| 9901 | Label Clip - Beer | 12 | WHT | 699018881 | | | 251 |
| 9902 | Label Clip - Beer Mug | 12 | WHT | 699028881 | | | 251 |
| 9903 | Label Clip - Brandy | 12 | WHT | 699038881 | | | 251 |
| 9904 | Label Clip - Champagne | 12 | WHT | 699048881 | | | 251 |
| 9905 | Label Clip - Champagne Mug | 12 | WHT | 699058881 | | | 251 |
| 9906 | Label Clip - Coffee Mug | 12 | WHT | 699068881 | | | 251 |
| 9907 | Label Clip - Colline | 12 | WHT | 699078881 | | | 251 |
| 9908 | Label Clip - Cordial | 12 | WHT | 699088881 | | | 251 |
| 9909 | Label Clip - Creamer | 12 | WHT | 699098881 | | | 251 |
| 9910 | Label Clip - Cup | 12 | WHT | 699108881 | | | 251 |
| 9911 | Label Clip - Decanter | 12 | WHT | 699118881 | | | 251 |
| 9912 | Label Clip - Flatware | 12 | WHT | 699128881 | | | 251 |
| 9913 | Label Clip - Goblet | 12 | WHT | 699138881 | | | 251 |
| 9914 | Label Clip - Grande | 12 | WHT | 699148881 | | | 251 |
| 9915 | Label Clip - Hi-Ball | 12 | WHT | 699158881 | | | 251 |
| 9916 | Label Clip - Hurricane | 12 | WHT | 699168881 | | | 251 |
| 9917 | Label Clip - Iced Tea | 12 | WHT | 699178881 | | | 251 |
| 9918 | Label Clip - Irish Coffee | 12 | WHT | 699188881 | | | 251 |
| 9919 | Label Clip - Juice | 12 | WHT | 699198881 | | | 251 |
| 9920 | Label Clip - Margarita | 12 | WHT | 699208881 | | | 251 |

PRODUCT INDEX

| No. | Product Name | Pack | Color | Order Code | Color | Order Code | Page |
|----------|--|------|-------|------------|-------|------------|----------|
| 9921 | Label Clip - Martini | 12 | WHT | 699218881 | | | 251 |
| 9922 | Label Clip - Old Fashion | 12 | WHT | 699228881 | | | 251 |
| 9923 | Label Clip - Pilsner | 12 | WHT | 699238881 | | | 251 |
| 9924 | Label Clip - Red Wine | 12 | WHT | 699248881 | | | 251 |
| 9925 | Label Clip - Rocks (Footed) | 12 | WHT | 699258881 | | | 251 |
| 9926 | Label Clip - Rocks (Tumbler) | 12 | WHT | 699268881 | | | 251 |
| 9927 | Label Clip - Sherry | 12 | WHT | 699278881 | | | 251 |
| 9928 | Label Clip - Shot Glass | 12 | WHT | 699288881 | | | 251 |
| 9929 | Label Clip - Sorbet | 12 | WHT | 699298881 | | | 251 |
| 9930 | Label Clip - Water (Footed) | 12 | WHT | 699308881 | | | 251 |
| 9931 | Label Clip - Water (Tumbler) | 12 | WHT | 699318881 | | | 251 |
| 9932 | Label Clip - White Wine | 12 | WHT | 699328881 | | | 251 |
| 9933 | Label Clip - Wine | 12 | WHT | 699338881 | | | 251 |
| 9934 | Label Clip - Port | 12 | WHT | 699348881 | | | 251 |
| 25113 | Hedgehog® Cleaning Tool Rack Base, 300mm | 12 | BLUE | 572608881 | RED | 572608883 | 132, 265 |
| | | | VGRN | 572608882 | GLD | 572608885 | |
| 25114 | Hedgehog® Cleaning Tool Rack Base, 500mm | 12 | BLUE | 572618881 | RED | 572618883 | 132, 265 |
| | | | VGRN | 572618882 | GLD | 572618885 | |
| 25115 | Hedgehog® Cleaning Tool Rack Base, 900mm | 12 | BLUE | 572628881 | RED | 572628883 | 132, 265 |
| | | | VGRN | 572628882 | GLD | 572628885 | |
| 25116 | Hedgehog® Small Stuck Clip | 12 | BLUE | 572638881 | RED | 572638883 | 132, 265 |
| | | | VGRN | 572638882 | GLD | 572638885 | |
| 25117 | Hedgehog® Large Stuck Clip | 12 | BLUE | 572648881 | RED | 572648883 | 132, 265 |
| | | | VGRN | 572648882 | GLD | 572648885 | |
| 25118 | Hedgehog® Hook | 12 | BLUE | 572658881 | RED | 572658883 | 132, 265 |
| | | | VGRN | 572658882 | GLD | 572658885 | |
| 25119 | Hedgehog® Signboard | 12 | BLUE | 572668881 | RED | 572668883 | 132, 265 |
| | | | VGRN | 572668882 | GLD | 572668885 | |
| AE142464 | Firmgre® 4-Shelf Stationary Extension Kit - W360 x L610 x H1630mm | 1 | SGRAY | 602078881 | | | 208 |
| AE142472 | Firmgre® 4-Shelf Stationary Extension Kit - W360 x L610 x H1830mm | 1 | SGRAY | 602088881 | | | 208 |
| AE142484 | Firmgre® 4-Shelf Stationary Extension Kit - W360 x L610 x H2140mm | 1 | SGRAY | 602098881 | | | 208 |
| AE143064 | Firmgre® 4-Shelf Stationary Extension Kit - W360 x L760 x H1630mm | 1 | SGRAY | 602108881 | | | 208 |
| AE143072 | Firmgre® 4-Shelf Stationary Extension Kit - W360 x L760 x H1830mm | 1 | SGRAY | 602118881 | | | 208 |
| AE143084 | Firmgre® 4-Shelf Stationary Extension Kit - W360 x L760 x H2140mm | 1 | SGRAY | 602128881 | | | 208 |
| AE143664 | Firmgre® 4-Shelf Stationary Extension Kit - W360 x L910 x H1630mm | 1 | SGRAY | 602138881 | | | 208 |
| AE143672 | Firmgre® 4-Shelf Stationary Extension Kit - W360 x L910 x H1830mm | 1 | SGRAY | 602148881 | | | 208 |
| AE143684 | Firmgre® 4-Shelf Stationary Extension Kit - W360 x L910 x H2140mm | 1 | SGRAY | 602158881 | | | 208 |
| AE144264 | Firmgre® 4-Shelf Stationary Extension Kit - W360 x L1070 x H1630mm | 1 | SGRAY | 602168881 | | | 208 |
| AE144272 | Firmgre® 4-Shelf Stationary Extension Kit - W360 x L1070 x H1830mm | 1 | SGRAY | 602178881 | | | 208 |
| AE144284 | Firmgre® 4-Shelf Stationary Extension Kit - W360 x L1070 x H2140mm | 1 | SGRAY | 602188881 | | | 208 |
| AE144864 | Firmgre® 4-Shelf Stationary Extension Kit - W360 x L1220 x H1630mm | 1 | SGRAY | 602198881 | | | 208 |
| AE144872 | Firmgre® 4-Shelf Stationary Extension Kit - W360 x L1220 x H1830mm | 1 | SGRAY | 602208881 | | | 208 |
| AE144884 | Firmgre® 4-Shelf Stationary Extension Kit - W360 x L1220 x H2140mm | 1 | SGRAY | 602218881 | | | 208 |
| AE145464 | Firmgre® 4-Shelf Stationary Extension Kit - W360 x L1380 x H1630mm | 1 | SGRAY | 602228881 | | | 208 |
| AE145472 | Firmgre® 4-Shelf Stationary Extension Kit - W360 x L1380 x H1830mm | 1 | SGRAY | 602238881 | | | 208 |
| AE145484 | Firmgre® 4-Shelf Stationary Extension Kit - W360 x L1380 x H2140mm | 1 | SGRAY | 602248881 | | | 208 |
| AE146064 | Firmgre® 4-Shelf Stationary Extension Kit - W360 x L1530 x H1630mm | 1 | SGRAY | 602258881 | | | 208 |
| AE146072 | Firmgre® 4-Shelf Stationary Extension Kit - W360 x L1530 x H1830mm | 1 | SGRAY | 602268881 | | | 208 |
| AE146084 | Firmgre® 4-Shelf Stationary Extension Kit - W360 x L1530 x H2140mm | 1 | SGRAY | 602278881 | | | 208 |

| No. | Product Name | Pack | Color | Order Code | Color | Order Code | Page |
|----------|--|------|-------|------------|-------|------------|------|
| AE147264 | Firmgre® 4-Shelf Stationary Extension Kit - W360 x L1830 x H1630mm | 1 | SGRAY | 602288881 | | | 208 |
| AE147272 | Firmgre® 4-Shelf Stationary Extension Kit - W360 x L1830 x H1830mm | 1 | SGRAY | 602298881 | | | 208 |
| AE147284 | Firmgre® 4-Shelf Stationary Extension Kit - W360 x L1830 x H2140mm | 1 | SGRAY | 602308881 | | | 208 |
| AE147864 | Firmgre® 4-Shelf Stationary Extension Kit - W360 x L1980 x H1630mm | 1 | SGRAY | 602318881 | | | 208 |
| AE147872 | Firmgre® 4-Shelf Stationary Extension Kit - W360 x L1980 x H1830mm | 1 | SGRAY | 602328881 | | | 208 |
| AE147884 | Firmgre® 4-Shelf Stationary Extension Kit - W360 x L1980 x H2140mm | 1 | SGRAY | 602338881 | | | 208 |
| AE182464 | Firmgre® 4-Shelf Stationary Extension Kit - W460 x L610 x H1630mm | 1 | SGRAY | 602618881 | | | 208 |
| AE182472 | Firmgre® 4-Shelf Stationary Extension Kit - W460 x L610 x H1830mm | 1 | SGRAY | 602628881 | | | 208 |
| AE182484 | Firmgre® 4-Shelf Stationary Extension Kit - W460 x L610 x H2140mm | 1 | SGRAY | 602638881 | | | 208 |
| AE183064 | Firmgre® 4-Shelf Stationary Extension Kit - W460 x L760 x H1630mm | 1 | SGRAY | 602648881 | | | 208 |
| AE183072 | Firmgre® 4-Shelf Stationary Extension Kit - W460 x L760 x H1830mm | 1 | SGRAY | 602658881 | | | 208 |
| AE183084 | Firmgre® 4-Shelf Stationary Extension Kit - W460 x L760 x H2140mm | 1 | SGRAY | 602668881 | | | 208 |
| AE183664 | Firmgre® 4-Shelf Stationary Extension Kit - W460 x L910 x H1630mm | 1 | SGRAY | 602678881 | | | 208 |
| AE183672 | Firmgre® 4-Shelf Stationary Extension Kit - W460 x L910 x H1830mm | 1 | SGRAY | 602688881 | | | 208 |
| AE183684 | Firmgre® 4-Shelf Stationary Extension Kit - W460 x L910 x H2140mm | 1 | SGRAY | 602698881 | | | 208 |
| AE184264 | Firmgre® 4-Shelf Stationary Extension Kit - W460 x L1070 x H1630mm | 1 | SGRAY | 602708881 | | | 208 |
| AE184272 | Firmgre® 4-Shelf Stationary Extension Kit - W460 x L1070 x H1830mm | 1 | SGRAY | 602718881 | | | 208 |
| AE184284 | Firmgre® 4-Shelf Stationary Extension Kit - W460 x L1070 x H2140mm | 1 | SGRAY | 602728881 | | | 208 |
| AE184864 | Firmgre® 4-Shelf Stationary Extension Kit - W460 x L1220 x H1630mm | 1 | SGRAY | 602738881 | | | 208 |
| AE184872 | Firmgre® 4-Shelf Stationary Extension Kit - W460 x L1220 x H1830mm | 1 | SGRAY | 602748881 | | | 208 |
| AE184884 | Firmgre® 4-Shelf Stationary Extension Kit - W460 x L1220 x H2140mm | 1 | SGRAY | 602758881 | | | 208 |
| AE185464 | Firmgre® 4-Shelf Stationary Extension Kit - W460 x L1380 x H1630mm | 1 | SGRAY | 602768881 | | | 208 |
| AE185472 | Firmgre® 4-Shelf Stationary Extension Kit - W460 x L1380 x H1830mm | 1 | SGRAY | 602778881 | | | 208 |
| AE185484 | Firmgre® 4-Shelf Stationary Extension Kit - W460 x L1380 x H2140mm | 1 | SGRAY | 602788881 | | | 208 |
| AE186064 | Firmgre® 4-Shelf Stationary Extension Kit - W460 x L1530 x H1630mm | 1 | SGRAY | 602798881 | | | 208 |
| AE186072 | Firmgre® 4-Shelf Stationary Extension Kit - W460 x L1530 x H1830mm | 1 | SGRAY | 602808881 | | | 208 |
| AE186084 | Firmgre® 4-Shelf Stationary Extension Kit - W460 x L1530 x H2140mm | 1 | SGRAY | 602818881 | | | 208 |
| AE187264 | Firmgre® 4-Shelf Stationary Extension Kit - W460 x L1830 x H1630mm | 1 | SGRAY | 602828881 | | | 208 |
| AE187272 | Firmgre® 4-Shelf Stationary Extension Kit - W460 x L1830 x H1830mm | 1 | SGRAY | 602838881 | | | 208 |
| AE187284 | Firmgre® 4-Shelf Stationary Extension Kit - W460 x L1830 x H2140mm | 1 | SGRAY | 602848881 | | | 208 |
| AE187864 | Firmgre® 4-Shelf Stationary Extension Kit - W460 x L1980 x H1630mm | 1 | SGRAY | 602858881 | | | 208 |
| AE187872 | Firmgre® 4-Shelf Stationary Extension Kit - W460 x L1980 x H1830mm | 1 | SGRAY | 602868881 | | | 208 |
| AE187884 | Firmgre® 4-Shelf Stationary Extension Kit - W460 x L1980 x H2140mm | 1 | SGRAY | 602878881 | | | 208 |
| AE212464 | Firmgre® 4-Shelf Stationary Extension Kit - W540 - L610 - H1630mm | 1 | SGRAY | 603158881 | | | 209 |
| AE212472 | Firmgre® 4-Shelf Stationary Extension Kit - W540 - L610 - H1830mm | 1 | SGRAY | 603168881 | | | 209 |
| AE212484 | Firmgre® 4-Shelf Stationary Extension Kit - W540 - L610 - H2140mm | 1 | SGRAY | 603178881 | | | 209 |
| AE213064 | Firmgre® 4-Shelf Stationary Extension Kit - W540 - L760 - H1630mm | 1 | SGRAY | 603188881 | | | 209 |

PRODUCT INDEX

| No. | Product Name | Pack | Color | Order Code | Color | Order Code | Page |
|----------|---|------|-------|------------|-------|------------|------|
| AE213072 | Firmgre® 4-Shelf Stationary Extension Kit - W540 - L760 - H1830mm | 1 | SGRAY | 603198881 | | | 209 |
| AE213084 | Firmgre® 4-Shelf Stationary Extension Kit - W540 - L760 - H2140mm | 1 | SGRAY | 603208881 | | | 209 |
| AE213664 | Firmgre® 4-Shelf Stationary Extension Kit - W540 - L910 - H1630mm | 1 | SGRAY | 603218881 | | | 209 |
| AE213672 | Firmgre® 4-Shelf Stationary Extension Kit - W540 - L910 - H1830mm | 1 | SGRAY | 603228881 | | | 209 |
| AE213684 | Firmgre® 4-Shelf Stationary Extension Kit - W540 - L910 - H2140mm | 1 | SGRAY | 603238881 | | | 209 |
| AE214264 | Firmgre® 4-Shelf Stationary Extension Kit - W540 - L1070 - H1630mm | 1 | SGRAY | 603248881 | | | 209 |
| AE214272 | Firmgre® 4-Shelf Stationary Extension Kit - W540 - L1070 - H1830mm | 1 | SGRAY | 603258881 | | | 209 |
| AE214284 | Firmgre® 4-Shelf Stationary Extension Kit - W540 - L1070 - H2140mm | 1 | SGRAY | 603268881 | | | 209 |
| AE214864 | Firmgre® 4-Shelf Stationary Extension Kit - W540 - L1220 - H1630mm | 1 | SGRAY | 603278881 | | | 209 |
| AE214872 | Firmgre® 4-Shelf Stationary Extension Kit - W540 - L1220 - H1830mm | 1 | SGRAY | 603288881 | | | 209 |
| AE214884 | Firmgre® 4-Shelf Stationary Extension Kit - W540 - L1220 - H2140mm | 1 | SGRAY | 603298881 | | | 209 |
| AE215464 | Firmgre® 4-Shelf Stationary Extension Kit - W540 - L1380 - H1630mm | 1 | SGRAY | 603308881 | | | 209 |
| AE215472 | Firmgre® 4-Shelf Stationary Extension Kit - W540 - L1380 - H1830mm | 1 | SGRAY | 603318881 | | | 209 |
| AE215484 | Firmgre® 4-Shelf Stationary Extension Kit - W540 - L1380 - H2140mm | 1 | SGRAY | 603328881 | | | 209 |
| AE216064 | Firmgre® 4-Shelf Stationary Extension Kit - W540 - L1530 - H1630mm | 1 | SGRAY | 603338881 | | | 209 |
| AE216072 | Firmgre® 4-Shelf Stationary Extension Kit - W540 - L1530 - H1830mm | 1 | SGRAY | 603348881 | | | 209 |
| AE216084 | Firmgre® 4-Shelf Stationary Extension Kit - W540 - L1530 - H2140mm | 1 | SGRAY | 603358881 | | | 209 |
| AE217264 | Firmgre® 4-Shelf Stationary Extension Kit - W540 - L1830 - H1630mm | 1 | SGRAY | 603368881 | | | 209 |
| AE217272 | Firmgre® 4-Shelf Stationary Extension Kit - W540 - L1830 - H1830mm | 1 | SGRAY | 603378881 | | | 209 |
| AE217284 | Firmgre® 4-Shelf Stationary Extension Kit - W540 - L1830 - H2140mm | 1 | SGRAY | 603388881 | | | 209 |
| AE217864 | Firmgre® 4-Shelf Stationary Extension Kit - W540 - L1980 - H1630mm | 1 | SGRAY | 603398881 | | | 209 |
| AE217872 | Firmgre® 4-Shelf Stationary Extension Kit - W540 - L1980 - H1830mm | 1 | SGRAY | 603408881 | | | 209 |
| AE217884 | Firmgre® 4-Shelf Stationary Extension Kit - W540 - L1980 - H2140mm | 1 | SGRAY | 603418881 | | | 209 |
| AE242464 | Firmgre® 4-Shelf Stationary Extension Kit - W610 × L610 × H1630mm | 1 | SGRAY | 603698881 | | | 209 |
| AE242472 | Firmgre® 4-Shelf Stationary Extension Kit - W610 × L610 × H1830mm | 1 | SGRAY | 603708881 | | | 209 |
| AE242484 | Firmgre® 4-Shelf Stationary Extension Kit - W610 × L610 × H2140mm | 1 | SGRAY | 603718881 | | | 209 |
| AE243064 | Firmgre® 4-Shelf Stationary Extension Kit - W610 × L760 × H1630mm | 1 | SGRAY | 603728881 | | | 209 |
| AE243072 | Firmgre® 4-Shelf Stationary Extension Kit - W610 × L760 × H1830mm | 1 | SGRAY | 603738881 | | | 209 |
| AE243084 | Firmgre® 4-Shelf Stationary Extension Kit - W610 × L760 × H2140mm | 1 | SGRAY | 603748881 | | | 209 |
| AE243664 | Firmgre® 4-Shelf Stationary Extension Kit - W610 × L910 × H1630mm | 1 | SGRAY | 603758881 | | | 209 |
| AE243672 | Firmgre® 4-Shelf Stationary Extension Kit - W610 × L910 × H1830mm | 1 | SGRAY | 603768881 | | | 209 |
| AE243684 | Firmgre® 4-Shelf Stationary Extension Kit - W610 × L910 × H2140mm | 1 | SGRAY | 603778881 | | | 209 |
| AE244264 | Firmgre® 4-Shelf Stationary Extension Kit - W610 × L1070 × H1630mm | 1 | SGRAY | 603788881 | | | 209 |
| AE244272 | Firmgre® 4-Shelf Stationary Extension Kit - W610 × L1070 × H1830mm | 1 | SGRAY | 603798881 | | | 209 |
| AE244284 | Firmgre® 4-Shelf Stationary Extension Kit - W610 × L1070 × H2140mm | 1 | SGRAY | 603808881 | | | 209 |
| AE244864 | Firmgre® 4-Shelf Stationary Extension Kit - W610 × L1220 × H1630mm | 1 | SGRAY | 603818881 | | | 209 |
| AE244872 | Firmgre® 4-Shelf Stationary Extension Kit - W610 × L1220 × H1830mm | 1 | SGRAY | 603828881 | | | 209 |

| No. | Product Name | Pack | Color | Order Code | Color | Order Code | Page |
|----------|--|------|-------|------------|-------|------------|------|
| AE244884 | Firmgre® 4-Shelf Stationary Extension Kit - W610 x L1220 x H2140mm | 1 | SGRAY | 603838881 | | | 209 |
| AE245464 | Firmgre® 4-Shelf Stationary Extension Kit - W610 x L1380 x H1630mm | 1 | SGRAY | 603848881 | | | 209 |
| AE245472 | Firmgre® 4-Shelf Stationary Extension Kit - W610 x L1380 x H1830mm | 1 | SGRAY | 603858881 | | | 209 |
| AE245484 | Firmgre® 4-Shelf Stationary Extension Kit - W610 x L1380 x H2140mm | 1 | SGRAY | 603868881 | | | 209 |
| AE246064 | Firmgre® 4-Shelf Stationary Extension Kit - W610 x L1530 x H1630mm | 1 | SGRAY | 603878881 | | | 209 |
| AE246072 | Firmgre® 4-Shelf Stationary Extension Kit - W610 x L1530 x H1830mm | 1 | SGRAY | 603888881 | | | 209 |
| AE246084 | Firmgre® 4-Shelf Stationary Extension Kit - W610 x L1530 x H2140mm | 1 | SGRAY | 603898881 | | | 209 |
| AE247264 | Firmgre® 4-Shelf Stationary Extension Kit - W610 x L1830 x H1630mm | 1 | SGRAY | 603908881 | | | 209 |
| AE247272 | Firmgre® 4-Shelf Stationary Extension Kit - W610 x L1830 x H1830mm | 1 | SGRAY | 603918881 | | | 209 |
| AE247284 | Firmgre® 4-Shelf Stationary Extension Kit - W610 x L1830 x H2140mm | 1 | SGRAY | 603928881 | | | 209 |
| AE247864 | Firmgre® 4-Shelf Stationary Extension Kit - W610 x L1980 x H1630mm | 1 | SGRAY | 603938881 | | | 209 |
| AE247872 | Firmgre® 4-Shelf Stationary Extension Kit - W610 x L1980 x H1830mm | 1 | SGRAY | 603948881 | | | 209 |
| AE247884 | Firmgre® 4-Shelf Stationary Extension Kit - W610 x L1980 x H2140mm | 1 | SGRAY | 603958881 | | | 209 |
| AM143670 | Firmgre® 4-Shelf Mobile Storage Kit - W360 x L910 x H1780mm | 1 | SGRAY | 603968881 | | | 210 |
| AM143678 | Firmgre® 4-Shelf Mobile Storage Kit - W360 x L910 x H1980mm | 1 | SGRAY | 603978881 | | | 210 |
| AM144270 | Firmgre® 4-Shelf Mobile Storage Kit - W360 x L1070 x H1780mm | 1 | SGRAY | 603988881 | | | 210 |
| AM144278 | Firmgre® 4-Shelf Mobile Storage Kit - W360 x L1070 x H1980mm | 1 | SGRAY | 603998881 | | | 210 |
| AM144870 | Firmgre® 4-Shelf Mobile Storage Kit - W360 x L1220 x H1780mm | 1 | SGRAY | 604008881 | | | 210 |
| AM144878 | Firmgre® 4-Shelf Mobile Storage Kit - W360 x L1220 x H1980mm | 1 | SGRAY | 604018881 | | | 210 |
| AM145470 | Firmgre® 4-Shelf Mobile Storage Kit - W360 x L1380 x H1780mm | 1 | SGRAY | 604028881 | | | 210 |
| AM145478 | Firmgre® 4-Shelf Mobile Storage Kit - W360 x L1380 x H1980mm | 1 | SGRAY | 604038881 | | | 210 |
| AM146070 | Firmgre® 4-Shelf Mobile Storage Kit - W360 x L1530 x H1780mm | 1 | SGRAY | 604048881 | | | 210 |
| AM146078 | Firmgre® 4-Shelf Mobile Storage Kit - W360 x L1530 x H1980mm | 1 | SGRAY | 604058881 | | | 210 |
| AM183670 | Firmgre® 4-Shelf Mobile Storage Kit - W460 x L910 x H1780mm | 1 | SGRAY | 604068881 | | | 210 |
| AM183678 | Firmgre® 4-Shelf Mobile Storage Kit - W460 x L910 x H1980mm | 1 | SGRAY | 604078881 | | | 210 |
| AM184270 | Firmgre® 4-Shelf Mobile Storage Kit - W460 x L1070 x H1780mm | 1 | SGRAY | 604088881 | | | 210 |
| AM184278 | Firmgre® 4-Shelf Mobile Storage Kit - W460 x L1070 x H1980mm | 1 | SGRAY | 604098881 | | | 210 |
| AM184870 | Firmgre® 4-Shelf Mobile Storage Kit - W460 x L1220 x H1780mm | 1 | SGRAY | 604108881 | | | 210 |
| AM184878 | Firmgre® 4-Shelf Mobile Storage Kit - W460 x L1220 x H1980mm | 1 | SGRAY | 604118881 | | | 210 |
| AM185470 | Firmgre® 4-Shelf Mobile Storage Kit - W460 x L1380 x H1780mm | 1 | SGRAY | 604128881 | | | 210 |
| AM185478 | Firmgre® 4-Shelf Mobile Storage Kit - W460 x L1380 x H1980mm | 1 | SGRAY | 604138881 | | | 210 |
| AM186070 | Firmgre® 4-Shelf Mobile Storage Kit - W460 x L1530 x H1780mm | 1 | SGRAY | 604148881 | | | 210 |
| AM186078 | Firmgre® 4-Shelf Mobile Storage Kit - W460 x L1530 x H1980mm | 1 | SGRAY | 604158881 | | | 210 |
| AM213670 | Firmgre® 4-Shelf Mobile Storage Kit - W540 x L910 x H1780mm | 1 | SGRAY | 604168881 | | | 210 |
| AM213678 | Firmgre® 4-Shelf Mobile Storage Kit - W540 x L910 x H1980mm | 1 | SGRAY | 604178881 | | | 210 |
| AM214270 | Firmgre® 4-Shelf Mobile Storage Kit - W540 x L1070 x H1780mm | 1 | SGRAY | 604188881 | | | 210 |
| AM214278 | Firmgre® 4-Shelf Mobile Storage Kit - W540 x L1070 x H1980mm | 1 | SGRAY | 604198881 | | | 210 |

PRODUCT INDEX

| No. | Product Name | Pack | Color | Order Code | Color | Order Code | Page |
|----------|---|------|-------|------------|-------|------------|------|
| AM214870 | Firmgre® 4-Shelf Mobile Storage Kit - W540 x L1220 x H1780mm | 1 | SGRAY | 604208881 | | | 210 |
| AM214878 | Firmgre® 4-Shelf Mobile Storage Kit - W540 x L1220 x H1980mm | 1 | SGRAY | 604218881 | | | 210 |
| AM215470 | Firmgre® 4-Shelf Mobile Storage Kit - W540 x L1380 x H1780mm | 1 | SGRAY | 604228881 | | | 210 |
| AM215478 | Firmgre® 4-Shelf Mobile Storage Kit - W540 x L1380 x H1980mm | 1 | SGRAY | 604238881 | | | 210 |
| AM216070 | Firmgre® 4-Shelf Mobile Storage Kit - W540 x L1530 x H1780mm | 1 | SGRAY | 604248881 | | | 210 |
| AM216078 | Firmgre® 4-Shelf Mobile Storage Kit - W540 x L1530 x H1980mm | 1 | SGRAY | 604258881 | | | 210 |
| AM243670 | Firmgre® 4-Shelf Mobile Storage Kit - W610 x L910 x H1780mm | 1 | SGRAY | 604268881 | | | 210 |
| AM243678 | Firmgre® 4-Shelf Mobile Storage Kit - W610 x L910 x H1980mm | 1 | SGRAY | 604278881 | | | 210 |
| AM244270 | Firmgre® 4-Shelf Mobile Storage Kit - W610 x L1070 x H1780mm | 1 | SGRAY | 604288881 | | | 210 |
| AM244278 | Firmgre® 4-Shelf Mobile Storage Kit - W610 x L1070 x H1980mm | 1 | SGRAY | 604298881 | | | 210 |
| AM244870 | Firmgre® 4-Shelf Mobile Storage Kit - W610 x L1220 x H1780mm | 1 | SGRAY | 604308881 | | | 210 |
| AM244878 | Firmgre® 4-Shelf Mobile Storage Kit - W610 x L1220 x H1980mm | 1 | SGRAY | 604318881 | | | 210 |
| AM245470 | Firmgre® 4-Shelf Mobile Storage Kit - W610 x L1380 x H1780mm | 1 | SGRAY | 604328881 | | | 210 |
| AM245478 | Firmgre® 4-Shelf Mobile Storage Kit - W610 x L1380 x H1980mm | 1 | SGRAY | 604338881 | | | 210 |
| AM246070 | Firmgre® 4-Shelf Mobile Storage Kit - W610 x L1530 x H1780mm | 1 | SGRAY | 604348881 | | | 210 |
| AM246078 | Firmgre® 4-Shelf Mobile Storage Kit - W610 x L1530 x H1980mm | 1 | SGRAY | 604358881 | | | 210 |
| AX142464 | Firmgre® 4-Shelf Stationary Starter Kit - W360 x L610 x H1630mm | 1 | SGRAY | 604368881 | | | 208 |
| AX142472 | Firmgre® 4-Shelf Stationary Starter Kit - W360 x L610 x H1830mm | 1 | SGRAY | 604378881 | | | 208 |
| AX142484 | Firmgre® 4-Shelf Stationary Starter Kit - W360 x L610 x H2140mm | 1 | SGRAY | 601828881 | | | 208 |
| AX143064 | Firmgre® 4-Shelf Stationary Starter Kit - W360 x L760 x H1630mm | 1 | SGRAY | 601838881 | | | 208 |
| AX143072 | Firmgre® 4-Shelf Stationary Starter Kit - W360 x L760 x H1830mm | 1 | SGRAY | 601848881 | | | 208 |
| AX143084 | Firmgre® 4-Shelf Stationary Starter Kit - W360 x L760 x H2140mm | 1 | SGRAY | 601858881 | | | 208 |
| AX143664 | Firmgre® 4-Shelf Stationary Starter Kit - W360 x L910 x H1630mm | 1 | SGRAY | 601868881 | | | 208 |
| AX143672 | Firmgre® 4-Shelf Stationary Starter Kit - W360 x L910 x H1830mm | 1 | SGRAY | 601878881 | | | 208 |
| AX143684 | Firmgre® 4-Shelf Stationary Starter Kit - W360 x L910 x H2140mm | 1 | SGRAY | 601888881 | | | 208 |
| AX144264 | Firmgre® 4-Shelf Stationary Starter Kit - W360 x L1070 x H1630mm | 1 | SGRAY | 601898881 | | | 208 |
| AX144272 | Firmgre® 4-Shelf Stationary Starter Kit - W360 x L1070 x H1830mm | 1 | SGRAY | 601908881 | | | 208 |
| AX144284 | Firmgre® 4-Shelf Stationary Starter Kit - W360 x L1070 x H2140mm | 1 | SGRAY | 601918881 | | | 208 |
| AX144864 | Firmgre® 4-Shelf Stationary Starter Kit - W360 x L1220 x H1630mm | 1 | SGRAY | 601928881 | | | 208 |
| AX144872 | Firmgre® 4-Shelf Stationary Starter Kit - W360 x L1220 x H1830mm | 1 | SGRAY | 601938881 | | | 208 |
| AX144884 | Firmgre® 4-Shelf Stationary Starter Kit - W360 x L1220 x H2140mm | 1 | SGRAY | 601948881 | | | 208 |
| AX145464 | Firmgre® 4-Shelf Stationary Starter Kit - W360 x L1380 x H1630mm | 1 | SGRAY | 601958881 | | | 208 |
| AX145472 | Firmgre® 4-Shelf Stationary Starter Kit - W360 x L1380 x H1830mm | 1 | SGRAY | 601968881 | | | 208 |
| AX145484 | Firmgre® 4-Shelf Stationary Starter Kit - W360 x L1380 x H2140mm | 1 | SGRAY | 601978881 | | | 208 |
| AX146064 | Firmgre® 4-Shelf Stationary Starter Kit - W360 x L1530 x H1630mm | 1 | SGRAY | 601988881 | | | 208 |
| AX146072 | Firmgre® 4-Shelf Stationary Starter Kit - W360 x L1530 x H1830mm | 1 | SGRAY | 601998881 | | | 208 |
| AX146084 | Firmgre® 4-Shelf Stationary Starter Kit - W360 x L1530 x H2140mm | 1 | SGRAY | 602008881 | | | 208 |

| No. | Product Name | Pack | Color | Order Code | Color | Order Code | Page |
|----------|--|------|-------|------------|-------|------------|------|
| AX147264 | Firmgre® 4-Shelf Stationary Starter Kit - W360 x L1830 x H1630mm | 1 | SGRAY | 602018881 | | | 208 |
| AX147272 | Firmgre® 4-Shelf Stationary Starter Kit - W360 x L1830 x H1830mm | 1 | SGRAY | 602028881 | | | 208 |
| AX147284 | Firmgre® 4-Shelf Stationary Starter Kit - W360 x L1830 x H2140mm | 1 | SGRAY | 602038881 | | | 208 |
| AX147864 | Firmgre® 4-Shelf Stationary Starter Kit - W360 x L1980 x H1630mm | 1 | SGRAY | 602048881 | | | 208 |
| AX147872 | Firmgre® 4-Shelf Stationary Starter Kit - W360 x L1980 x H1830mm | 1 | SGRAY | 602058881 | | | 208 |
| AX147884 | Firmgre® 4-Shelf Stationary Starter Kit - W360 x L1980 x H2140mm | 1 | SGRAY | 602068881 | | | 208 |
| AX182464 | Firmgre® 4-Shelf Stationary Starter Kit - W460 x L610 x H1630mm | 1 | SGRAY | 602348881 | | | 208 |
| AX182472 | Firmgre® 4-Shelf Stationary Starter Kit - W460 x L610 x H1830mm | 1 | SGRAY | 602358881 | | | 208 |
| AX182484 | Firmgre® 4-Shelf Stationary Starter Kit - W460 x L610 x H2140mm | 1 | SGRAY | 602368881 | | | 208 |
| AX183064 | Firmgre® 4-Shelf Stationary Starter Kit - W460 x L760 x H1630mm | 1 | SGRAY | 602378881 | | | 208 |
| AX183072 | Firmgre® 4-Shelf Stationary Starter Kit - W460 x L760 x H1830mm | 1 | SGRAY | 602388881 | | | 208 |
| AX183084 | Firmgre® 4-Shelf Stationary Starter Kit - W460 x L760 x H2140mm | 1 | SGRAY | 602398881 | | | 208 |
| AX183664 | Firmgre® 4-Shelf Stationary Starter Kit - W460 x L910 x H1630mm | 1 | SGRAY | 602408881 | | | 208 |
| AX183672 | Firmgre® 4-Shelf Stationary Starter Kit - W460 x L910 x H1830mm | 1 | SGRAY | 602418881 | | | 208 |
| AX183684 | Firmgre® 4-Shelf Stationary Starter Kit - W460 x L910 x H2140mm | 1 | SGRAY | 602428881 | | | 208 |
| AX184264 | Firmgre® 4-Shelf Stationary Starter Kit - W460 x L1070 x H1630mm | 1 | SGRAY | 602438881 | | | 208 |
| AX184272 | Firmgre® 4-Shelf Stationary Starter Kit - W460 x L1070 x H1830mm | 1 | SGRAY | 602448881 | | | 208 |
| AX184284 | Firmgre® 4-Shelf Stationary Starter Kit - W460 x L1070 x H2140mm | 1 | SGRAY | 602458881 | | | 208 |
| AX184864 | Firmgre® 4-Shelf Stationary Starter Kit - W460 x L1220 x H1630mm | 1 | SGRAY | 602468881 | | | 208 |
| AX184872 | Firmgre® 4-Shelf Stationary Starter Kit - W460 x L1220 x H1830mm | 1 | SGRAY | 602478881 | | | 208 |
| AX184884 | Firmgre® 4-Shelf Stationary Starter Kit - W460 x L1220 x H2140mm | 1 | SGRAY | 602488881 | | | 208 |
| AX185464 | Firmgre® 4-Shelf Stationary Starter Kit - W460 x L1380 x H1630mm | 1 | SGRAY | 602498881 | | | 208 |
| AX185472 | Firmgre® 4-Shelf Stationary Starter Kit - W460 x L1380 x H1830mm | 1 | SGRAY | 602508881 | | | 208 |
| AX185484 | Firmgre® 4-Shelf Stationary Starter Kit - W460 x L1380 x H2140mm | 1 | SGRAY | 602518881 | | | 208 |
| AX186064 | Firmgre® 4-Shelf Stationary Starter Kit - W460 x L1530 x H1630mm | 1 | SGRAY | 602528881 | | | 208 |
| AX186072 | Firmgre® 4-Shelf Stationary Starter Kit - W460 x L1530 x H1830mm | 1 | SGRAY | 602538881 | | | 208 |
| AX186084 | Firmgre® 4-Shelf Stationary Starter Kit - W460 x L1530 x H2140mm | 1 | SGRAY | 602548881 | | | 208 |
| AX187264 | Firmgre® 4-Shelf Stationary Starter Kit - W460 x L1830 x H1630mm | 1 | SGRAY | 602558881 | | | 208 |
| AX187272 | Firmgre® 4-Shelf Stationary Starter Kit - W460 x L1830 x H1830mm | 1 | SGRAY | 602568881 | | | 208 |
| AX187284 | Firmgre® 4-Shelf Stationary Starter Kit - W460 x L1830 x H2140mm | 1 | SGRAY | 602578881 | | | 208 |
| AX187864 | Firmgre® 4-Shelf Stationary Starter Kit - W460 x L1980 x H1630mm | 1 | SGRAY | 602588881 | | | 208 |
| AX187872 | Firmgre® 4-Shelf Stationary Starter Kit - W460 x L1980 x H1830mm | 1 | SGRAY | 602598881 | | | 208 |
| AX187884 | Firmgre® 4-Shelf Stationary Starter Kit - W460 x L1980 x H2140mm | 1 | SGRAY | 602608881 | | | 208 |
| AX212464 | Firmgre® 4-Shelf Stationary Starter Kit - W540 x L610 x H1630mm | 1 | SGRAY | 602888881 | | | 209 |
| AX212472 | Firmgre® 4-Shelf Stationary Starter Kit - W540 x L610 x H1830mm | 1 | SGRAY | 602898881 | | | 209 |
| AX212484 | Firmgre® 4-Shelf Stationary Starter Kit - W540 x L610 x H2140mm | 1 | SGRAY | 602908881 | | | 209 |
| AX213064 | Firmgre® 4-Shelf Stationary Starter Kit - W540 x L760 x H1630mm | 1 | SGRAY | 602918881 | | | 209 |

PRODUCT INDEX

| No. | Product Name | Pack | Color | Order Code | Color | Order Code | Page |
|----------|---|------|-------|------------|-------|------------|------|
| AX213072 | Firmgre® 4-Shelf Stationary Starter Kit - W540 x L760 x H1830mm | 1 | SGRAY | 602928881 | | | 209 |
| AX213084 | Firmgre® 4-Shelf Stationary Starter Kit - W540 x L760 x H2140mm | 1 | SGRAY | 602938881 | | | 209 |
| AX213664 | Firmgre® 4-Shelf Stationary Starter Kit - W540 x L910 x H1630mm | 1 | SGRAY | 602948881 | | | 209 |
| AX213672 | Firmgre® 4-Shelf Stationary Starter Kit - W540 x L910 x H1830mm | 1 | SGRAY | 602958881 | | | 209 |
| AX213684 | Firmgre® 4-Shelf Stationary Starter Kit - W540 x L910 x H2140mm | 1 | SGRAY | 602968881 | | | 209 |
| AX214264 | Firmgre® 4-Shelf Stationary Starter Kit - W540 x L1070 x H1630mm | 1 | SGRAY | 602978881 | | | 209 |
| AX214272 | Firmgre® 4-Shelf Stationary Starter Kit - W540 x L1070 x H1830mm | 1 | SGRAY | 602988881 | | | 209 |
| AX214284 | Firmgre® 4-Shelf Stationary Starter Kit - W540 x L1070 x H2140mm | 1 | SGRAY | 602998881 | | | 209 |
| AX214864 | Firmgre® 4-Shelf Stationary Starter Kit - W540 x L1220 x H1630mm | 1 | SGRAY | 603008881 | | | 209 |
| AX214872 | Firmgre® 4-Shelf Stationary Starter Kit - W540 x L1220 x H1830mm | 1 | SGRAY | 603018881 | | | 209 |
| AX214884 | Firmgre® 4-Shelf Stationary Starter Kit - W540 x L1220 x H2140mm | 1 | SGRAY | 603028881 | | | 209 |
| AX215464 | Firmgre® 4-Shelf Stationary Starter Kit - W540 x L1380 x H1630mm | 1 | SGRAY | 603038881 | | | 209 |
| AX215472 | Firmgre® 4-Shelf Stationary Starter Kit - W540 x L1380 x H1830mm | 1 | SGRAY | 603048881 | | | 209 |
| AX215484 | Firmgre® 4-Shelf Stationary Starter Kit - W540 x L1380 x H2140mm | 1 | SGRAY | 603058881 | | | 209 |
| AX216064 | Firmgre® 4-Shelf Stationary Starter Kit - W540 x L1530 x H1630mm | 1 | SGRAY | 603068881 | | | 209 |
| AX216072 | Firmgre® 4-Shelf Stationary Starter Kit - W540 x L1530 x H1830mm | 1 | SGRAY | 603078881 | | | 209 |
| AX216084 | Firmgre® 4-Shelf Stationary Starter Kit - W540 x L1530 x H2140mm | 1 | SGRAY | 603088881 | | | 209 |
| AX217264 | Firmgre® 4-Shelf Stationary Starter Kit - W540 x L1830 x H1630mm | 1 | SGRAY | 603098881 | | | 209 |
| AX217272 | Firmgre® 4-Shelf Stationary Starter Kit - W540 x L1830 x H1830mm | 1 | SGRAY | 603108881 | | | 209 |
| AX217284 | Firmgre® 4-Shelf Stationary Starter Kit - W540 x L1830 x H2140mm | 1 | SGRAY | 603118881 | | | 209 |
| AX217864 | Firmgre® 4-Shelf Stationary Starter Kit - W540 x L1980 x H1630mm | 1 | SGRAY | 603128881 | | | 209 |
| AX217872 | Firmgre® 4-Shelf Stationary Starter Kit - W540 x L1980 x H1830mm | 1 | SGRAY | 603138881 | | | 209 |
| AX217884 | Firmgre® 4-Shelf Stationary Starter Kit - W540 x L1980 x H2140mm | 1 | SGRAY | 603148881 | | | 209 |
| AX242464 | Firmgre® 4-Shelf Stationary Starter Kit - W610 x L610 x H1630mm | 1 | SGRAY | 603428881 | | | 209 |
| AX242472 | Firmgre® 4-Shelf Stationary Starter Kit - W610 x L610 x H1830mm | 1 | SGRAY | 603438881 | | | 209 |
| AX242484 | Firmgre® 4-Shelf Stationary Starter Kit - W610 x L610 x H2140mm | 1 | SGRAY | 603448881 | | | 209 |
| AX243064 | Firmgre® 4-Shelf Stationary Starter Kit - W610 x L760 x H1630mm | 1 | SGRAY | 603458881 | | | 209 |
| AX243072 | Firmgre® 4-Shelf Stationary Starter Kit - W610 x L760 x H1830mm | 1 | SGRAY | 603468881 | | | 209 |
| AX243084 | Firmgre® 4-Shelf Stationary Starter Kit - W610 x L760 x H2140mm | 1 | SGRAY | 603478881 | | | 209 |
| AX243664 | Firmgre® 4-Shelf Stationary Starter Kit - W610 x L910 x H1630mm | 1 | SGRAY | 603488881 | | | 209 |
| AX243672 | Firmgre® 4-Shelf Stationary Starter Kit - W610 x L910 x H1830mm | 1 | SGRAY | 603498881 | | | 209 |
| AX243684 | Firmgre® 4-Shelf Stationary Starter Kit - W610 x L910 x H2140mm | 1 | SGRAY | 603508881 | | | 209 |
| AX244264 | Firmgre® 4-Shelf Stationary Starter Kit - W610 x L1070 x H1630mm | 1 | SGRAY | 603518881 | | | 209 |
| AX244272 | Firmgre® 4-Shelf Stationary Starter Kit - W610 x L1070 x H1830mm | 1 | SGRAY | 603528881 | | | 209 |
| AX244284 | Firmgre® 4-Shelf Stationary Starter Kit - W610 x L1070 x H2140mm | 1 | SGRAY | 603538881 | | | 209 |
| AX244864 | Firmgre® 4-Shelf Stationary Starter Kit - W610 x L1220 x H1630mm | 1 | SGRAY | 603548881 | | | 209 |
| AX244872 | Firmgre® 4-Shelf Stationary Starter Kit - W610 x L1220 x H1830mm | 1 | SGRAY | 603558881 | | | 209 |

| No. | Product Name | Pack | Color | Order Code | Color | Order Code | Page |
|-------------|--|------|-------|-------------|-------|------------|------|
| AX244884 | Firmgre® 4-Shelf Stationary Starter Kit - W610 x L1220 x H2140mm | 1 | SGRAY | 603568881 | | | 209 |
| AX245464 | Firmgre® 4-Shelf Stationary Starter Kit - W610 x L1380 x H1630mm | 1 | SGRAY | 603578881 | | | 209 |
| AX245472 | Firmgre® 4-Shelf Stationary Starter Kit - W610 x L1380 x H1830mm | 1 | SGRAY | 603588881 | | | 209 |
| AX245484 | Firmgre® 4-Shelf Stationary Starter Kit - W610 x L1380 x H2140mm | 1 | SGRAY | 603598881 | | | 209 |
| AX246064 | Firmgre® 4-Shelf Stationary Starter Kit - W610 x L1530 x H1630mm | 1 | SGRAY | 603608881 | | | 209 |
| AX246072 | Firmgre® 4-Shelf Stationary Starter Kit - W610 x L1530 x H1830mm | 1 | SGRAY | 603618881 | | | 209 |
| AX246084 | Firmgre® 4-Shelf Stationary Starter Kit - W610 x L1530 x H2140mm | 1 | SGRAY | 603628881 | | | 209 |
| AX247264 | Firmgre® 4-Shelf Stationary Starter Kit - W610 x L1830 x H1630mm | 1 | SGRAY | 603638881 | | | 209 |
| AX247272 | Firmgre® 4-Shelf Stationary Starter Kit - W610 x L1830 x H1830mm | 1 | SGRAY | 603648881 | | | 209 |
| AX247284 | Firmgre® 4-Shelf Stationary Starter Kit - W610 x L1830 x H2140mm | 1 | SGRAY | 603658881 | | | 209 |
| AX247864 | Firmgre® 4-Shelf Stationary Starter Kit - W610 x L1980 x H1630mm | 1 | SGRAY | 603668881 | | | 209 |
| AX247872 | Firmgre® 4-Shelf Stationary Starter Kit - W610 x L1980 x H1830mm | 1 | SGRAY | 603678881 | | | 209 |
| AX247884 | Firmgre® 4-Shelf Stationary Starter Kit - W610 x L1980 x H2140mm | 1 | SGRAY | 603688881 | | | 209 |
| BC1210 | Top | | BLA | 2A029137010 | | | 178 |
| BC4845 | Top | | BLA | 2A008137010 | | | 178 |
| BCHA1210-09 | Heavy-load Bulk Container | | BLA | 8A0308881 | | | 178 |
| BCHA1210-10 | Heavy-load Bulk Container | | BLA | 8A0308882 | | | 178 |
| BCHA1210-11 | Heavy-load Bulk Container | | BLA | 8A0308883 | | | 178 |
| BCHA4845-25 | Heavy-load Bulk Container | | BLA | 8A0088886 | | | 178 |
| BCHA4845-34 | Heavy-load Bulk Container | | BLA | 8A0088883 | | | 178 |
| BCHA4845-39 | Heavy-load Bulk Container | | BLA | 8A0088882 | | | 178 |
| BCHA4845-42 | Heavy-load Bulk Container | | BLA | 8A0088885 | | | 178 |
| BCHA4845-46 | Heavy-load Bulk Container | | BLA | 8A0088884 | | | 178 |
| BE183064 | Firmgre® Modus 4-Shelf Stationary Extension Kit - W460 x L760 x H1630mm | 1 | SGRAY | 604848881 | | | 214 |
| BE183072 | Firmgre® Modus 4-Shelf Stationary Extension Kit - W460 x L760 x H1830mm | 1 | SGRAY | 604858881 | | | 214 |
| BE183084 | Firmgre® Modus 4-Shelf Stationary Extension Kit - W460 x L760 x H2140mm | 1 | SGRAY | 604868881 | | | 214 |
| BE183664 | Firmgre® Modus 4-Shelf Stationary Extension Kit - W460 x L910 x H1630mm | 1 | SGRAY | 604878881 | | | 214 |
| BE183672 | Firmgre® Modus 4-Shelf Stationary Extension Kit - W460 x L910 x H1830mm | 1 | SGRAY | 604888881 | | | 214 |
| BE183684 | Firmgre® Modus 4-Shelf Stationary Extension Kit - W460 x L910 x H2140mm | 1 | SGRAY | 604898881 | | | 214 |
| BE184264 | Firmgre® Modus 4-Shelf Stationary Extension Kit - W460 x L1070 x H1630mm | 1 | SGRAY | 604908881 | | | 214 |
| BE184272 | Firmgre® Modus 4-Shelf Stationary Extension Kit - W460 x L1070 x H1830mm | 1 | SGRAY | 604918881 | | | 214 |
| BE184284 | Firmgre® Modus 4-Shelf Stationary Extension Kit - W460 x L1070 x H2140mm | 1 | SGRAY | 604928881 | | | 214 |
| BE184864 | Firmgre® Modus 4-Shelf Stationary Extension Kit - W460 x L1220 x H1630mm | 1 | SGRAY | 604938881 | | | 214 |
| BE184872 | Firmgre® Modus 4-Shelf Stationary Extension Kit - W460 x L1220 x H1830mm | 1 | SGRAY | 604948881 | | | 214 |
| BE184884 | Firmgre® Modus 4-Shelf Stationary Extension Kit - W460 x L1220 x H2140mm | 1 | SGRAY | 604958881 | | | 214 |
| BE185464 | Firmgre® Modus 4-Shelf Stationary Extension Kit - W460 x L1380 x H1630mm | 1 | SGRAY | 604968881 | | | 214 |
| BE185472 | Firmgre® Modus 4-Shelf Stationary Extension Kit - W460 x L1380 x H1830mm | 1 | SGRAY | 604978881 | | | 214 |
| BE185484 | Firmgre® Modus 4-Shelf Stationary Extension Kit - W460 x L1380 x H2140mm | 1 | SGRAY | 604988881 | | | 214 |
| BE186064 | Firmgre® Modus 4-Shelf Stationary Extension Kit - W460 x L1530 x H1630mm | 1 | SGRAY | 604998881 | | | 214 |
| BE186072 | Firmgre® Modus 4-Shelf Stationary Extension Kit - W460 x L1530 x H1830mm | 1 | SGRAY | 605008881 | | | 214 |
| BE186084 | Firmgre® Modus 4-Shelf Stationary Extension Kit - W460 x L1530 x H2140mm | 1 | SGRAY | 605018881 | | | 214 |

PRODUCT INDEX

| No. | Product Name | Pack | Color | Order Code | Color | Order Code | Page |
|----------|---|------|-------|------------|-------|------------|------|
| BE213064 | Firmgre® Modus 4-Shelf Stationary Extension Kit - W540 x L760 x H1630mm | 1 | SGRAY | 605028881 | | | 215 |
| BE213072 | Firmgre® Modus 4-Shelf Stationary Extension Kit - W540 x L760 x H1830mm | 1 | SGRAY | 605038881 | | | 215 |
| BE213084 | Firmgre® Modus 4-Shelf Stationary Extension Kit - W540 x L760 x H2140mm | 1 | SGRAY | 605048881 | | | 215 |
| BE213664 | Firmgre® Modus 4-Shelf Stationary Extension Kit - W540 x L910 x H1630mm | 1 | SGRAY | 605058881 | | | 215 |
| BE213672 | Firmgre® Modus 4-Shelf Stationary Extension Kit - W540 x L910 x H1830mm | 1 | SGRAY | 605068881 | | | 215 |
| BE213684 | Firmgre® Modus 4-Shelf Stationary Extension Kit - W540 x L910 x H2140mm | 1 | SGRAY | 605078881 | | | 215 |
| BE214264 | Firmgre® Modus 4-Shelf Stationary Extension Kit - W540 x L1070 x H1630mm | 1 | SGRAY | 605088881 | | | 215 |
| BE214272 | Firmgre® Modus 4-Shelf Stationary Extension Kit - W540 x L1070 x H1830mm | 1 | SGRAY | 605098881 | | | 215 |
| BE214284 | Firmgre® Modus 4-Shelf Stationary Extension Kit - W540 x L1070 x H2140mm | 1 | SGRAY | 605108881 | | | 215 |
| BE214864 | Firmgre® Modus 4-Shelf Stationary Extension Kit - W540 x L1220 x H1630mm | 1 | SGRAY | 605118881 | | | 215 |
| BE214872 | Firmgre® Modus 4-Shelf Stationary Extension Kit - W540 x L1220 x H1830mm | 1 | SGRAY | 605128881 | | | 215 |
| BE214884 | Firmgre® Modus 4-Shelf Stationary Extension Kit - W540 x L1220 x H2140mm | 1 | SGRAY | 605138881 | | | 215 |
| BE215464 | Firmgre® Modus 4-Shelf Stationary Extension Kit - W540 x L1380 x H1630mm | 1 | SGRAY | 605148881 | | | 215 |
| BE215472 | Firmgre® Modus 4-Shelf Stationary Extension Kit - W540 x L1380 x H1830mm | 1 | SGRAY | 605158881 | | | 215 |
| BE215484 | Firmgre® Modus 4-Shelf Stationary Extension Kit - W540 x L1380 x H2140mm | 1 | SGRAY | 605168881 | | | 215 |
| BE216064 | Firmgre® Modus 4-Shelf Stationary Extension Kit - W540 x L1530 x H1630mm | 1 | SGRAY | 605178881 | | | 215 |
| BE216072 | Firmgre® Modus 4-Shelf Stationary Extension Kit - W540 x L1530 x H1830mm | 1 | SGRAY | 605188881 | | | 215 |
| BE216084 | Firmgre® Modus 4-Shelf Stationary Extension Kit - W540 x L1530 x H2140mm | 1 | SGRAY | 605198881 | | | 215 |
| BE243064 | Firmgre® Modus 4-Shelf Stationary Extension Kit - W610 x L760 x H1630mm | 1 | SGRAY | 605208881 | | | 215 |
| BE243072 | Firmgre® Modus 4-Shelf Stationary Extension Kit - W610 x L760 x H1830mm | 1 | SGRAY | 605218881 | | | 215 |
| BE243084 | Firmgre® Modus 4-Shelf Stationary Extension Kit - W610 x L760 x H2140mm | 1 | SGRAY | 605228881 | | | 215 |
| BE243664 | Firmgre® Modus 4-Shelf Stationary Extension Kit - W610 x L910 x H1630mm | 1 | SGRAY | 605238881 | | | 215 |
| BE243672 | Firmgre® Modus 4-Shelf Stationary Extension Kit - W610 x L910 x H1830mm | 1 | SGRAY | 605248881 | | | 215 |
| BE243684 | Firmgre® Modus 4-Shelf Stationary Extension Kit - W610 x L910 x H2140mm | 1 | SGRAY | 605258881 | | | 215 |
| BE244264 | Firmgre® Modus 4-Shelf Stationary Extension Kit - W610 x L1070 x H1630mm | 1 | SGRAY | 605268881 | | | 215 |
| BE244272 | Firmgre® Modus 4-Shelf Stationary Extension Kit - W610 x L1070 x H1830mm | 1 | SGRAY | 605278881 | | | 215 |
| BE244284 | Firmgre® Modus 4-Shelf Stationary Extension Kit - W610 x L1070 x H2140mm | 1 | SGRAY | 605288881 | | | 215 |
| BE244864 | Firmgre® Modus 4-Shelf Stationary Extension Kit - W610 x L1220 x H1630mm | 1 | SGRAY | 605298881 | | | 215 |
| BE244872 | Firmgre® Modus 4-Shelf Stationary Extension Kit - W610 x L1220 x H1830mm | 1 | SGRAY | 605308881 | | | 215 |
| BE244884 | Firmgre® Modus 4-Shelf Stationary Extension Kit - W610 x L1220 x H2140mm | 1 | SGRAY | 605318881 | | | 215 |
| BE245464 | Firmgre® Modus 4-Shelf Stationary Extension Kit - W610 x L1380 x H1630mm | 1 | SGRAY | 605328881 | | | 215 |
| BE245472 | Firmgre® Modus 4-Shelf Stationary Extension Kit - W610 x L1380 x H1830mm | 1 | SGRAY | 605338881 | | | 215 |
| BE245484 | Firmgre® Modus 4-Shelf Stationary Extension Kit - W610 x L1380 x H2140mm | 1 | SGRAY | 605348881 | | | 215 |
| BE246064 | Firmgre® Modus 4-Shelf Stationary Extension Kit - W610 x L1530 x H1630mm | 1 | SGRAY | 605358881 | | | 215 |
| BE246072 | Firmgre® Modus 4-Shelf Stationary Extension Kit - W610 x L1530 x H1830mm | 1 | SGRAY | 605368881 | | | 215 |
| BE246084 | Firmgre® Modus 4-Shelf Stationary Extension Kit - W610 x L1530 x H2140mm | 1 | SGRAY | 605378881 | | | 215 |
| BX183064 | Firmgre® Modus 4-Shelf Stationary Starter Kit - W460 x L760 x H1630mm | 1 | SGRAY | 605388881 | | | 214 |

| No. | Product Name | Pack | Color | Order Code | Color | Order Code | Page |
|----------|--|------|-------|------------|-------|------------|------|
| BX183072 | Firmgre® Modus 4-Shelf Stationary Starter Kit - W460 x L760 x H1830mm | 1 | SGRAY | 605398881 | | | 214 |
| BX183084 | Firmgre® Modus 4-Shelf Stationary Starter Kit - W460 x L760 x H2140mm | 1 | SGRAY | 605408881 | | | 214 |
| BX183664 | Firmgre® Modus 4-Shelf Stationary Starter Kit - W460 x L910 x H1630mm | 1 | SGRAY | 605418881 | | | 214 |
| BX183672 | Firmgre® Modus 4-Shelf Stationary Starter Kit - W460 x L910 x H1830mm | 1 | SGRAY | 605428881 | | | 214 |
| BX183684 | Firmgre® Modus 4-Shelf Stationary Starter Kit - W460 x L910 x H2140mm | 1 | SGRAY | 605438881 | | | 214 |
| BX184264 | Firmgre® Modus 4-Shelf Stationary Starter Kit - W460 x L1070 x H1630mm | 1 | SGRAY | 605448881 | | | 214 |
| BX184272 | Firmgre® Modus 4-Shelf Stationary Starter Kit - W460 x L1070 x H1830mm | 1 | SGRAY | 605458881 | | | 214 |
| BX184284 | Firmgre® Modus 4-Shelf Stationary Starter Kit - W460 x L1070 x H2140mm | 1 | SGRAY | 605468881 | | | 214 |
| BX184864 | Firmgre® Modus 4-Shelf Stationary Starter Kit - W460 x L1220 x H1630mm | 1 | SGRAY | 605478881 | | | 214 |
| BX184872 | Firmgre® Modus 4-Shelf Stationary Starter Kit - W460 x L1220 x H1830mm | 1 | SGRAY | 605488881 | | | 214 |
| BX184884 | Firmgre® Modus 4-Shelf Stationary Starter Kit - W460 x L1220 x H2140mm | 1 | SGRAY | 605498881 | | | 214 |
| BX185464 | Firmgre® Modus 4-Shelf Stationary Starter Kit - W460 x L1380 x H1630mm | 1 | SGRAY | 605508881 | | | 214 |
| BX185472 | Firmgre® Modus 4-Shelf Stationary Starter Kit - W460 x L1380 x H1830mm | 1 | SGRAY | 605518881 | | | 214 |
| BX185484 | Firmgre® Modus 4-Shelf Stationary Starter Kit - W460 x L1380 x H2140mm | 1 | SGRAY | 605528881 | | | 214 |
| BX186064 | Firmgre® Modus 4-Shelf Stationary Starter Kit - W460 x L1530 x H1630mm | 1 | SGRAY | 605538881 | | | 214 |
| BX186072 | Firmgre® Modus 4-Shelf Stationary Starter Kit - W460 x L1530 x H1830mm | 1 | SGRAY | 605548881 | | | 214 |
| BX186084 | Firmgre® Modus 4-Shelf Stationary Starter Kit - W460 x L1530 x H2140mm | 1 | SGRAY | 605558881 | | | 214 |
| BX213064 | Firmgre® Modus 4-Shelf Stationary Starter Kit - W540 x L760 x H1630mm | 1 | SGRAY | 605568881 | | | 215 |
| BX213072 | Firmgre® Modus 4-Shelf Stationary Starter Kit - W540 x L760 x H1830mm | 1 | SGRAY | 605578881 | | | 215 |
| BX213084 | Firmgre® Modus 4-Shelf Stationary Starter Kit - W540 x L760 x H2140mm | 1 | SGRAY | 605588881 | | | 215 |
| BX213664 | Firmgre® Modus 4-Shelf Stationary Starter Kit - W540 x L910 x H1630mm | 1 | SGRAY | 605598881 | | | 215 |
| BX213672 | Firmgre® Modus 4-Shelf Stationary Starter Kit - W540 x L910 x H1830mm | 1 | SGRAY | 605608881 | | | 215 |
| BX213684 | Firmgre® Modus 4-Shelf Stationary Starter Kit - W540 x L910 x H2140mm | 1 | SGRAY | 605618881 | | | 215 |
| BX214264 | Firmgre® Modus 4-Shelf Stationary Starter Kit - W540 x L1070 x H1630mm | 1 | SGRAY | 605628881 | | | 215 |
| BX214272 | Firmgre® Modus 4-Shelf Stationary Starter Kit - W540 x L1070 x H1830mm | 1 | SGRAY | 605638881 | | | 215 |
| BX214284 | Firmgre® Modus 4-Shelf Stationary Starter Kit - W540 x L1070 x H2140mm | 1 | SGRAY | 605648881 | | | 215 |
| BX214864 | Firmgre® Modus 4-Shelf Stationary Starter Kit - W540 x L1220 x H1630mm | 1 | SGRAY | 605658881 | | | 215 |
| BX214872 | Firmgre® Modus 4-Shelf Stationary Starter Kit - W540 x L1220 x H1830mm | 1 | SGRAY | 605668881 | | | 215 |
| BX214884 | Firmgre® Modus 4-Shelf Stationary Starter Kit - W540 x L1220 x H2140mm | 1 | SGRAY | 605678881 | | | 215 |
| BX215464 | Firmgre® Modus 4-Shelf Stationary Starter Kit - W540 x L1380 x H1630mm | 1 | SGRAY | 605688881 | | | 215 |
| BX215472 | Firmgre® Modus 4-Shelf Stationary Starter Kit - W540 x L1380 x H1830mm | 1 | SGRAY | 605698881 | | | 215 |
| BX215484 | Firmgre® Modus 4-Shelf Stationary Starter Kit - W540 x L1380 x H2140mm | 1 | SGRAY | 605708881 | | | 215 |
| BX216064 | Firmgre® Modus 4-Shelf Stationary Starter Kit - W540 x L1530 x H1630mm | 1 | SGRAY | 605718881 | | | 215 |
| BX216072 | Firmgre® Modus 4-Shelf Stationary Starter Kit - W540 x L1530 x H1830mm | 1 | SGRAY | 605728881 | | | 215 |
| BX216084 | Firmgre® Modus 4-Shelf Stationary Starter Kit - W540 x L1530 x H2140mm | 1 | SGRAY | 605738881 | | | 215 |
| BX243064 | Firmgre® Modus 4-Shelf Stationary Starter Kit - W610 x L760 x H1630mm | 1 | SGRAY | 605748881 | | | 215 |
| BX243072 | Firmgre® Modus 4-Shelf Stationary Starter Kit - W610 x L760 x H1830mm | 1 | SGRAY | 605758881 | | | 215 |

PRODUCT INDEX

| No. | Product Name | Pack | Color | Order Code | Color | Order Code | Page |
|----------|--|------|-------|------------|-------|------------|------|
| BX243084 | Firmgre® Modus 4-Shelf Stationary Starter Kit - W610 x L760 x H2140mm | 1 | SGRAY | 605768881 | | | 215 |
| BX243664 | Firmgre® Modus 4-Shelf Stationary Starter Kit - W610 x L910 x H1630mm | 1 | SGRAY | 605778881 | | | 215 |
| BX243672 | Firmgre® Modus 4-Shelf Stationary Starter Kit - W610 x L910 x H1830mm | 1 | SGRAY | 605788881 | | | 215 |
| BX243684 | Firmgre® Modus 4-Shelf Stationary Starter Kit - W610 x L910 x H2140mm | 1 | SGRAY | 605798881 | | | 215 |
| BX244264 | Firmgre® Modus 4-Shelf Stationary Starter Kit - W610 x L1070 x H1630mm | 1 | SGRAY | 605808881 | | | 215 |
| BX244272 | Firmgre® Modus 4-Shelf Stationary Starter Kit - W610 x L1070 x H1830mm | 1 | SGRAY | 605818881 | | | 215 |
| BX244284 | Firmgre® Modus 4-Shelf Stationary Starter Kit - W610 x L1070 x H2140mm | 1 | SGRAY | 605828881 | | | 215 |
| BX244864 | Firmgre® Modus 4-Shelf Stationary Starter Kit - W610 x L1220 x H1630mm | 1 | SGRAY | 605838881 | | | 215 |
| BX244872 | Firmgre® Modus 4-Shelf Stationary Starter Kit - W610 x L1220 x H1830mm | 1 | SGRAY | 605848881 | | | 215 |
| BX244884 | Firmgre® Modus 4-Shelf Stationary Starter Kit - W610 x L1220 x H2140mm | 1 | SGRAY | 605858881 | | | 215 |
| BX245464 | Firmgre® Modus 4-Shelf Stationary Starter Kit - W610 x L1380 x H1630mm | 1 | SGRAY | 605868881 | | | 215 |
| BX245472 | Firmgre® Modus 4-Shelf Stationary Starter Kit - W610 x L1380 x H1830mm | 1 | SGRAY | 605878881 | | | 215 |
| BX245484 | Firmgre® Modus 4-Shelf Stationary Starter Kit - W610 x L1380 x H2140mm | 1 | SGRAY | 605888881 | | | 215 |
| BX246064 | Firmgre® Modus 4-Shelf Stationary Starter Kit - W610 x L1530 x H1630mm | 1 | SGRAY | 605898881 | | | 215 |
| BX246072 | Firmgre® Modus 4-Shelf Stationary Starter Kit - W610 x L1530 x H1830mm | 1 | SGRAY | 605908881 | | | 215 |
| BX246084 | Firmgre® Modus 4-Shelf Stationary Starter Kit - W610 x L1530 x H2140mm | 1 | SGRAY | 605918881 | | | 215 |
| PNB1111 | Nestable Pallet | | BLA | 8A0208881 | | | 176 |
| PNB1208 | Nestable Pallet | | BLA | 8A0238881 | | | 176 |
| PNB1210 | Nestable Pallet | | BLA | 8A0028881 | | | 176 |
| PRB1210 | Shelf Pallet | | BLA | 8A0068881 | | | 177 |
| PSB1210 | Stacking Pallet | | BLA | 8A0158889 | | | 177 |
| XA1800 | Firmgre® Modus Dunnage Stand - W460 x H170mm | 1 | GRAY | 604468881 | | | 217 |
| XA1801 | Firmgre® Modus Dunnage Stand - W460 x H270mm | 1 | GRAY | 604478881 | | | 217 |
| XA1864 | Firmgre® Modus Stationary Post Kit - W460 x H1630mm | 1 | GRAY | 604528881 | | | 217 |
| XA1872 | Firmgre® Modus Stationary Post Kit - W460 x H1830mm | 1 | GRAY | 604538881 | | | 217 |
| XA1884 | Firmgre® Modus Stationary Post Kit - W460 x H2140mm | 1 | GRAY | 604548881 | | | 217 |
| XA2100 | Firmgre® Modus Dunnage Stand - W540 x H170mm | 1 | GRAY | 604488881 | | | 217 |
| XA2101 | Firmgre® Modus Dunnage Stand - W540 x H270mm | 1 | GRAY | 604498881 | | | 217 |
| XA2164 | Firmgre® Modus Stationary Post Kit - W540 x H1630mm | 1 | GRAY | 604558881 | | | 217 |
| XA2172 | Firmgre® Modus Stationary Post Kit - W540 x H1830mm | 1 | GRAY | 604568881 | | | 217 |
| XA2184 | Firmgre® Modus Stationary Post Kit - W540 x H2140mm | 1 | GRAY | 604578881 | | | 217 |
| XA2400 | Firmgre® Modus Dunnage Stand - W610 x H170mm | 1 | GRAY | 604508881 | | | 217 |
| XA2401 | Firmgre® Modus Dunnage Stand - W610 x H270mm | 1 | GRAY | 604518881 | | | 217 |
| XA2464 | Firmgre® Modus Stationary Post Kit - W610 x H1630mm | 1 | GRAY | 604588881 | | | 217 |
| XA2472 | Firmgre® Modus Stationary Post Kit - W610 x H1830mm | 1 | GRAY | 604598881 | | | 217 |
| XA2484 | Firmgre® Modus Stationary Post Kit - W610 x H2140mm | 1 | GRAY | 604608881 | | | 217 |
| XB0001 | Firmgre® Modus Corner Connector | 1 | GRAY | 604618881 | | | 216 |
| XB0002 | Firmgre® Modus Identification Tag 15cm | 12 | GRAY | 604628881 | | | 216 |
| XB0003 | Firmgre® Modus Identification Tag 7.6cm | 12 | GRAY | 604638881 | | | 216 |
| XB0004 | Firmgre® Modus Wall Fastener | 4 | SS | 604648881 | | | 216 |
| XB0005 | Firmgre® Modus Seismic Foot | 4 | SS | 604658881 | | | 216 |
| XB1830 | Firmgre® Modus Shelf Kit - W460 x L760mm | 1 | SGRAY | 604668881 | | | 217 |
| XB1836 | Firmgre® Modus Shelf Kit - W460 x L910mm | 1 | SGRAY | 604678881 | | | 217 |
| XB1842 | Firmgre® Modus Shelf Kit - W460 x L1070mm | 1 | SGRAY | 604688881 | | | 217 |
| XB1848 | Firmgre® Modus Shelf Kit - W460 x L1220mm | 1 | SGRAY | 604698881 | | | 217 |
| XB1854 | Firmgre® Modus Shelf Kit - W460 x L1380mm | 1 | SGRAY | 604708881 | | | 217 |
| XB1860 | Firmgre® Modus Shelf Kit - W460 x L1530mm | 1 | SGRAY | 604718881 | | | 217 |
| XB2130 | Firmgre® Modus Shelf Kit - W540 x L760mm | 1 | SGRAY | 604728881 | | | 217 |
| XB2136 | Firmgre® Modus Shelf Kit - W540 x L910mm | 1 | SGRAY | 604738881 | | | 217 |
| XB2142 | Firmgre® Modus Shelf Kit - W540 x L1070mm | 1 | SGRAY | 604748881 | | | 217 |
| XB2148 | Firmgre® Modus Shelf Kit - W540 x L1220mm | 1 | SGRAY | 604758881 | | | 217 |
| XB2154 | Firmgre® Modus Shelf Kit - W540 x L1380mm | 1 | SGRAY | 604768881 | | | 217 |

| No. | Product Name | Pack | Color | Order Code | Color | Order Code | Page |
|--------|---|------|-------|------------|-------|------------|------|
| XB2160 | Firmgre® Modus Shelf Kit - W540 x L1530mm | 1 | SGRAY | 604778881 | | | 217 |
| XB2430 | Firmgre® Modus Shelf Kit - W610 x 760mm | 1 | SGRAY | 604788881 | | | 217 |
| XB2436 | Firmgre® Modus Shelf Kit - W610 x 910mm | 1 | SGRAY | 604798881 | | | 217 |
| XB2442 | Firmgre® Modus Shelf Kit - W610 x 1070mm | 1 | SGRAY | 604808881 | | | 217 |
| XB2448 | Firmgre® Modus Shelf Kit - W610 x 1220mm | 1 | SGRAY | 604818881 | | | 217 |
| XB2454 | Firmgre® Modus Shelf Kit - W610 x 1380mm | 1 | SGRAY | 604828881 | | | 217 |
| XB2460 | Firmgre® Modus Shelf Kit - W610 x 1530mm | 1 | SGRAY | 604838881 | | | 217 |
| XM1470 | Firmgre® Mobile Post Kit - W360 x H1780mm | 1 | GRAY | 604388881 | | | 211 |
| XM1478 | Firmgre® Mobile Post Kit - W360 x H1980mm | 1 | GRAY | 604398881 | | | 211 |
| XM1870 | Firmgre® Mobile Post Kit - W460 x H1780mm | 1 | GRAY | 604408881 | | | 211 |
| XM1878 | Firmgre® Mobile Post Kit - W460 x H1980mm | 1 | GRAY | 604418881 | | | 211 |
| XM2170 | Firmgre® Mobile Post Kit - W540 x H1780mm | 1 | GRAY | 604428881 | | | 211 |
| XM2178 | Firmgre® Mobile Post Kit - W540 x H1980mm | 1 | GRAY | 604438881 | | | 211 |
| XM2470 | Firmgre® Mobile Post Kit - W610 x H1780mm | 1 | GRAY | 604448881 | | | 211 |
| XM2478 | Firmgre® Mobile Post Kit - W610 x H1980mm | 1 | GRAY | 604458881 | | | 211 |
| XX0001 | Firmgre® Corner Connector | 1 | GRAY | 601648881 | | | 212 |
| XX0002 | Firmgre® Identification Tag 15cm | 12 | GRAY | 601658881 | | | 212 |
| XX0003 | Firmgre® Identification Tag 7.6cm | 12 | GRAY | 601668881 | | | 212 |
| XX0004 | Firmgre® Wall Fastener | 4 | SS | 601678881 | | | 212 |
| XX0005 | Firmgre® Seismic Foot | 4 | SS | 601688881 | | | 212 |
| XX0006 | Firmgre® Swivel Castors | 1 | GRAY | 601698881 | | | 212 |
| XX0007 | Firmgre® Swivel Castors with Brake | 1 | GRAY | 601708881 | | | 212 |
| XX1424 | Firmgre® Shelf Kit - W360 x L610mm | 1 | SGRAY | 601248881 | | | 211 |
| XX1430 | Firmgre® Shelf Kit - W360 x L760mm | 1 | SGRAY | 601258881 | | | 211 |
| XX1436 | Firmgre® Shelf Kit - W360 x L910mm | 1 | SGRAY | 601268881 | | | 211 |
| XX1442 | Firmgre® Shelf Kit - W360 x L1070mm | 1 | SGRAY | 601278881 | | | 211 |
| XX1448 | Firmgre® Shelf Kit - W360 x L1220mm | 1 | SGRAY | 601288881 | | | 211 |
| XX1454 | Firmgre® Shelf Kit - W360 x L1380mm | 1 | SGRAY | 601298881 | | | 211 |
| XX1460 | Firmgre® Shelf Kit - W360 x L1530mm | 1 | SGRAY | 601308881 | | | 211 |
| XX1472 | Firmgre® Shelf Kit - W360 x L1830mm | 1 | SGRAY | 601318881 | | | 211 |
| XX1478 | Firmgre® Shelf Kit - W360 x L1980mm | 1 | SGRAY | 601328881 | | | 211 |
| XX1824 | Firmgre® Shelf Kit - W460 x L610mm | 1 | SGRAY | 601338881 | | | 211 |
| XX1830 | Firmgre® Shelf Kit - W460 x L760mm | 1 | SGRAY | 601348881 | | | 211 |
| XX1836 | Firmgre® Shelf Kit - W460 x L910mm | 1 | SGRAY | 601358881 | | | 211 |
| XX1842 | Firmgre® Shelf Kit - W460 x L1070mm | 1 | SGRAY | 601368881 | | | 211 |
| XX1848 | Firmgre® Shelf Kit - W460 x L1220mm | 1 | SGRAY | 601378881 | | | 211 |
| XX1854 | Firmgre® Shelf Kit - W460 x L1380mm | 1 | SGRAY | 601388881 | | | 211 |
| XX1860 | Firmgre® Shelf Kit - W460 x L1530mm | 1 | SGRAY | 601398881 | | | 211 |
| XX1872 | Firmgre® Shelf Kit - W460 x L1830mm | 1 | SGRAY | 601408881 | | | 211 |
| XX1878 | Firmgre® Shelf Kit - W460 x L1980mm | 1 | SGRAY | 601418881 | | | 211 |
| XX2124 | Firmgre® Shelf Kit - W540 x L610mm | 1 | SGRAY | 601428881 | | | 211 |
| XX2130 | Firmgre® Shelf Kit - W540 x L760mm | 1 | SGRAY | 601438881 | | | 211 |
| XX2136 | Firmgre® Shelf Kit - W540 x L910mm | 1 | SGRAY | 601448881 | | | 211 |
| XX2142 | Firmgre® Shelf Kit - W540 x L1070mm | 1 | SGRAY | 601458881 | | | 211 |
| XX2148 | Firmgre® Shelf Kit - W540 x L1220mm | 1 | SGRAY | 601468881 | | | 211 |
| XX2154 | Firmgre® Shelf Kit - W540 x L1380mm | 1 | SGRAY | 601478881 | | | 211 |
| XX2160 | Firmgre® Shelf Kit - W540 x L1530mm | 1 | SGRAY | 601488881 | | | 211 |
| XX2172 | Firmgre® Shelf Kit - W540 x L1830mm | 1 | SGRAY | 601498881 | | | 211 |
| XX2178 | Firmgre® Shelf Kit - W540 x L1980mm | 1 | SGRAY | 601508881 | | | 211 |
| XX2424 | Firmgre® Shelf Kit - W610 x L610mm | 1 | SGRAY | 601518881 | | | 211 |
| XX2430 | Firmgre® Shelf Kit - W610 x L760mm | 1 | SGRAY | 601528881 | | | 211 |
| XX2436 | Firmgre® Shelf Kit - W610 x L910mm | 1 | SGRAY | 601538881 | | | 211 |
| XX2442 | Firmgre® Shelf Kit - W610 x L1070mm | 1 | SGRAY | 601548881 | | | 211 |
| XX2448 | Firmgre® Shelf Kit - W610 x L1220mm | 1 | SGRAY | 601558881 | | | 211 |
| XX2454 | Firmgre® Shelf Kit - W610 x L1380mm | 1 | SGRAY | 601568881 | | | 211 |
| XX2460 | Firmgre® Shelf Kit - W610 x L1530mm | 1 | SGRAY | 601578881 | | | 211 |
| XX2472 | Firmgre® Shelf Kit - W610 x L1830mm | 1 | SGRAY | 601588881 | | | 211 |
| XX2478 | Firmgre® Shelf Kit - W610 x L1980mm | 1 | SGRAY | 601598881 | | | 211 |
| XY1400 | Firmgre® Dunnage Stand - W360mm x 165mm | 1 | GRAY | 601608881 | | | 211 |
| XY1464 | Firmgre® Stationary Post Kit - W360 x H1630mm | 1 | GRAY | 601038881 | | | 211 |
| XY1472 | Firmgre® Stationary Post Kit - W360 x H1830mm | 1 | GRAY | 601048881 | | | 211 |
| XY1484 | Firmgre® Stationary Post Kit - W360 x H2140mm | 1 | GRAY | 601058881 | | | 211 |
| XY1800 | Firmgre® Dunnage Stand - W460mm x 165mm | 1 | GRAY | 601618881 | | | 211 |
| XY1864 | Firmgre® Stationary Post Kit - W460 x H1630mm | 1 | GRAY | 601098881 | | | 211 |

PRODUCT INDEX

| No. | Product Name | Pack | Color | Order Code | Color | Order Code | Page |
|--------|---|------|-------|------------|-------|------------|------|
| XY1872 | Firmgre® Stationary Post Kit - W460 × H1830mm | 1 | GRAY | 601108881 | | | 211 |
| XY1884 | Firmgre® Stationary Post Kit - W460 × H2140mm | 1 | GRAY | 601118881 | | | 211 |
| XY2100 | Firmgre® Dunnage Stand - W540mm × 165mm | 1 | GRAY | 601628881 | | | 211 |
| XY2164 | Firmgre® Stationary Post Kit - W540 × H1630mm | 1 | GRAY | 601158881 | | | 211 |
| XY2172 | Firmgre® Stationary Post Kit - W540 × H1830mm | 1 | GRAY | 601168881 | | | 211 |
| XY2184 | Firmgre® Stationary Post Kit - W540 × H2140mm | 1 | GRAY | 601178881 | | | 211 |
| XY2400 | Firmgre® Dunnage Stand - W610mm × 165mm | 1 | GRAY | 601638881 | | | 211 |
| XY2464 | Firmgre® Stationary Post Kit - W610 × H1630mm | 1 | GRAY | 601218881 | | | 211 |
| XY2472 | Firmgre® Stationary Post Kit - W610 × H1830mm | 1 | GRAY | 601228881 | | | 211 |
| XY2484 | Firmgre® Stationary Post Kit - W610 × H2140mm | 1 | GRAY | 601238881 | | | 211 |

| Fits | Part Number | Part Description | Page |
|------|-------------|---------------------------|--------|
| 1021 | 1021-02 | Lid (Specify Color) | 12 |
| | 1021-03 | Pin | |
| | 1021-04 | 20 cm Dia Wheel | |
| 1022 | 1021-02 | Lid (Specify Color) | 37 |
| | 1021-03 | Pin | |
| | 1021-04 | 20 cm Dia Wheel | |
| 1031 | 1031-02 | Lid (Specify Color) | 13 |
| | 1031-03 | Fixed Block | |
| | 1031-04 | 20 cm Dia Wheel | |
| 1032 | 1032-02 | Lid (Specify Color) | 13 |
| | 1032-03 | Fixed Block | |
| | 1031-04 | 20 cm Dia Wheel | |
| 1033 | 1033-02 | Lid (Specify Color) | 13 |
| | 1033-03 | Fixed Block | |
| | 1033-04 | 30 cm Dia Wheel | |
| 1034 | 1034-02 | Lid (Specify Color) | 13 |
| | 1034-03 | Fixed Block | |
| | 1033-04 | 30 cm Dia Wheel | |
| 1035 | 1031-02 | Lid (Specify Color) | 14, 24 |
| | 1031-03 | Fixed Block | |
| | 1031-04 | 20 cm Dia Wheel | |
| | 1035-01 | Pedal | |
| 1036 | 1032-02 | Lid (Specify Color) | 14, 24 |
| | 1032-03 | Fixed Block | |
| | 1031-04 | 20 cm Dia Wheel | |
| | 1036-01 | Pedal | |
| 1037 | 1033-02 | Lid (Specify Color) | 14, 24 |
| | 1033-03 | Fixed Block | |
| | 1033-04 | 30 cm Dia Wheel | |
| | 1037-01 | Pedal | |
| 1038 | 1034-02 | Lid (Specify Color) | 14, 24 |
| | 1034-03 | Fixed Block | |
| | 1033-04 | 30 cm Dia Wheel | |
| | 1038-01 | Pedal | |
| 1041 | 1031-02 | Lid (Specify Color) | 13 |
| | 1031-03 | Fixed Block | |
| | 1031-04 | 20 cm Dia Wheel | |
| | 1041-01 | 7.5 cm Dia Swivel Caster | |
| 1042 | 1032-02 | Lid (Specify Color) | 13 |
| | 1032-03 | Fixed Block | |
| | 1031-04 | 20 cm Dia Wheel | |
| | 1041-01 | 7.5 cm Dia Swivel Caster | |
| 1043 | 1033-02 | Lid (Specify Color) | 13 |
| | 1033-03 | Fixed Block | |
| | 1033-04 | 30 cm Dia Wheel | |
| | 1043-01 | 10.0 cm Dia Swivel Caster | |
| 1044 | 1034-02 | Lid (Specify Color) | 13 |
| | 1034-03 | Fixed Block | |
| | 1033-04 | 30 cm Dia Wheel | |
| | 1043-01 | 10.0 cm Dia Swivel Caster | |
| 1045 | 1031-02 | Lid (Specify Color) | 14, 24 |
| | 1031-03 | Fixed Block | |
| | 1031-04 | 20 cm Dia Wheel | |
| | 1035-01 | Pedal | |

| Fits | Part Number | Part Description | Page |
|------|-------------|---------------------------|--------|
| 1045 | 1041-01 | 7.5 cm Dia Swivel Caster | 14, 24 |
| 1046 | 1032-02 | Lid (Specify Color) | 14, 24 |
| | 1032-03 | Fixed Block | |
| | 1031-04 | 20 cm Dia Wheel | |
| | 1041-01 | 7.5 cm Dia Swivel Caster | |
| 1047 | 1036-01 | Pedal | |
| | 1033-02 | Lid (Specify Color) | 14, 24 |
| | 1033-03 | Fixed Block | |
| | 1033-04 | 30 cm Dia Wheel | |
| | 1043-01 | 10.0 cm Dia Swivel Caster | |
| 1048 | 1037-01 | Pedal | |
| | 1034-02 | Lid (Specify Color) | 14, 24 |
| | 1034-03 | Fixed Block | |
| | 1033-04 | 30 cm Dia Wheel | |
| | 1043-01 | 10.0 cm Dia Swivel Caster | |
| 1252 | 1038-01 | Pedal | |
| | 1252-02 | Lifter | 21 |
| | 1253-03 | Pedal | |
| 1253 | 1253-02 | Lid (Specify Color) | |
| | 174208 | Soft Close | |
| | 1253-04 | Lifter | 21 |
| | 1253-03 | Pedal | |
| 1254 | 1253-02 | Lid (Specify Color) | |
| | 174208 | Soft Close | |
| | 1254-04 | Lifter | 21 |
| | 1254-03 | Pedal | |
| 1255 | 1254-02 | Lid (Specify Color) | |
| | 174208 | Soft Close | |
| | 1255-02 | Lifter | 21 |
| | 1254-03 | Pedal | |
| 1256 | 1254-02 | Lid (Specify Color) | |
| | 174208 | Soft Close | |
| | 1256-02 | Lifter | 41 |
| 1257 | 1253-03 | Pedal | |
| | 1253-02 | Lid (Specify Color) | |
| | 174208 | Soft Close | |
| | 1253-03 | Pedal | |
| 1258 | 1254-04 | Lifter | 41 |
| | 1254-03 | Pedal | |
| | 1254-02 | Lid (Specify Color) | |
| | 174208 | Soft Close | |
| 1259 | 1255-02 | Lifter | 41 |
| | 1254-03 | Pedal | |
| | 1254-02 | Lid (Specify Color) | |
| | 174208 | Soft Close | |
| 1301 | 1301-01 | Lid (Sepecify Color) | 23 |
| | 1301-02 | Pedal | |
| | 1301-03 | Lifter | |
| 1302 | 174212 | Buffer | |
| | 1302-01 | Lid (Sepecify Color) | 23 |
| | 1302-02 | Pedal | |

COMPONENT INDEX

| Fits | Part Number | Part Description | Page |
|------|-------------|--|--------------------|
| 1302 | 1302-03 | Lifter | 23 |
| | 174212 | Buffer | |
| 1303 | 1303-01 | Lid (Specify Color) | 23 |
| | 1303-02 | Pedal | |
| | 1303-03 | Lifter | |
| | 174212 | Buffer | |
| 1304 | 1304-01 | Lid (Specify Color) | 23 |
| | 1304-02 | Pedal | |
| | 1304-03 | Lifter | |
| | 174212 | Buffer | |
| 1305 | 1305-01 | Lid (Specify Color) | 22 |
| | 1305-02 | Pedal | |
| | 1305-03 | Lifter | |
| | 174212 | Buffer | |
| 1306 | 1306-01 | Lid (Specify Color) | 22 |
| | 1306-02 | Pedal | |
| | 1306-03 | Lifter | |
| | 174212 | Buffer | |
| 1307 | 1307-01 | Lid (Specify Color) | 22 |
| | 1307-02 | Pedal | |
| | 1307-03 | Lifter | |
| | 174212 | Buffer | |
| 1308 | 1308-01 | Lid (Specify Color) | 22 |
| | 1308-02 | Pedal | |
| | 1308-03 | Lifter | |
| | 174212 | Buffer | |
| 1309 | 1309-01 | Lid (Specify Color) | 22 |
| | 1309-02 | Pedal | |
| | 1309-03 | Lifter | |
| | 1309-04 | Castor Wheel | |
| | 174212 | Buffer | |
| 1811 | 1811-01 | Round Chassis | 11, 29, 60, 61, 79 |
| | 176614 | 7.5 cm dia Caster | |
| 1812 | 1812-01 | Square Chassis | 29, 61, 187, 271 |
| | 176614 | 7.5 cm dia Caster | |
| 1813 | 1811-01 | Round Chassis | 11, 29, 61 |
| | 1813-01 | 7.5 cm dia Quiet Caster | |
| 1814 | 1814-01 | Rectangular Chassis | 20, 62, 63, 78 |
| | 176605 | 7.5 cm dia Caster | |
| 1815 | 1815-01 | Double-compartment Chassis | 20, 63 |
| | 176605 | 7.5 cm dia Caster | |
| 1816 | 1816-01 | Tri-Compartment Chassis | 20, 63 |
| | 176625 | 7.5 cm dia TPR Swivel Caster with Sleeve | |
| 1817 | 1817-01 | Four-Compartment Chassis | 20, 63 |
| | 176625 | 7.5 cm dia TPR Swivel Caster with Sleeve | |
| 1818 | 1818-01 | Chassis | 11, 29, 61 |
| | 1818-02 | 10 cm dia TPR Swivel Caster | |
| 1825 | 1825-01 | Rectangular Chassis | 62, 78 |
| | 176605 | 7.5 cm dia Caster | |
| 2011 | 1281-01 | Inner bucket | 43 |
| | 2011-01 | Base (Specify Color) | |
| | 2011-02 | Tops (Specify Color) | |
| | 2011-03 | With an Ashtray Atop (Specify Color) | |

| Fits | Part Number | Part Description | Page |
|------|-------------|---|------|
| 2011 | 2011-04 | ABS Pillar (Specify Color) | 43 |
| | 2011-05 | Square Steel Pillar | |
| | 2011-06 | Ashtray | |
| 2012 | 1281-01 | Inner bucket | 43 |
| | 2011-01 | Base (Specify Color) | |
| | 2011-02 | Tops (Specify Color) | |
| | 2012-01 | Funnel Tops (Specify Color) | |
| | 2011-04 | ABS Pillar (Specify Color) | |
| | 2011-05 | Square Steel Pillar | |
| 2021 | 1282-01 | Inner bucket | 43 |
| | 2021-01 | Base (Specify Color) | |
| | 2021-02 | Tops (Specify Color) | |
| | 2021-03 | Funnel Tops (Specify Color) | |
| | 2011-04 | ABS Pillar (Specify Color) | |
| | 2011-05 | Square Steel Pillar | |
| 2022 | 1282-01 | Inner bucket | 43 |
| | 2021-01 | Base (Specify Color) | |
| | 2021-02 | Tops (Specify Color) | |
| | 2022-01 | Funnel Tops (Specify Color) | |
| | 2011-04 | ABS Pillar | |
| | 2011-05 | Square Steel Pillar | |
| 2023 | 1282-01 | Inner bucket | 43 |
| | 2021-01 | Base (Specify Color) | |
| | 2023-01 | Tops (Specify Color) | |
| | 2023-02 | Drum Tops (Specify Color) | |
| | 2011-04 | ABS Pillar (Specify Color) | |
| | 2011-05 | Square Steel Pillar | |
| 2024 | 1282-01 | Inner Bucket | 43 |
| | 2021-01 | Base (Specify Color) | |
| | 2023-01 | Top (Specify Color) | |
| | 2024-01 | Drum Tops with Ashtray Fixing holes (Specify Color) | |
| | 2011-04 | ABS Pillar (Specify Color) | |
| | 2011-05 | Square Steel Pillar | |
| 2031 | 1283-01 | Inner Bucket | 43 |
| | 2021-01 | Base (Specify Color) | |
| | 2023-01 | Top (Specify Color) | |
| | 2023-02 | Drum Tops (Specify Color) | |
| | 2031-01 | ABS Pillar (Specify Color) | |
| | 2031-02 | Square Steel Pillar | |
| 2032 | 1283-01 | Inner Bucket | 43 |
| | 2021-01 | Base (Specify Color) | |
| | 2023-01 | Tops (Specify Color) | |
| | 2024-02 | Drum Tops with Ashtray Fixing Hole (Specify Color) | |
| 2051 | 2031-01 | ABS Pillar (Specify Color) | |
| | 2031-02 | Square Steel Pillar | |
| | 2021-02 | Square Steel Pillar | |
| 2052 | 2051-01 | Top Cover | 44 |
| | 2051-02 | Ashtray | |
| | 2051-03 | 9.5 L Steel Galvanized Barrel | |

| Fits | Part Number | Part Description | Page |
|---------|-------------|---------------------------------|------|
| 2061 | 2061-01 | Top Cover | 44 |
| | 2061-02 | Ashtray | |
| | 2061-03 | 45.4 L Steel Galvanized Barrel | |
| 2062 | 2062-01 | Top Cover | 44 |
| | 2061-03 | 45.4 L Steel Galvanized Barrel | |
| 2071 | 2071-01 | Ashtray | 44 |
| | 2071-02 | 90.8 L Steel Galvanized Barrel | |
| 2072 | 2071-02 | 90.8 L Steel Galvanized Barrel | 44 |
| 2081 | 2081-01 | 109.8 L Steel Galvanized Barrel | 44 |
| | 2081-02 | Adjustable Bolt Assembly | |
| 2082 | 2081-01 | 109.8 L Steel Galvanized Barrel | 44 |
| | 2081-02 | Adjustable Bolt Assembly | |
| 2083 | 2081-01 | 109.8 L Steel Galvanized Barrel | 44 |
| | 2081-02 | Adjustable Bolt Assembly | |
| 2091 | 2091-01 | 181.7 L Steel Galvanized Barrel | 44 |
| | 2081-02 | Adjustable Bolt Assembly | |
| 2092 | 2091-01 | 181.7 L Steel Galvanized Barrel | 44 |
| | 2081-02 | Adjustable Bolt Assembly | |
| 2093 | 2091-01 | 181.7 L Steel Galvanized Barrel | 44 |
| | 2081-02 | Adjustable Bolt Assembly | |
| 2101 | 2101-01 | Door Plank (Sepecify Color) | 52 |
| | 2101-02 | Base (Sepecify Color) | |
| | 2101-03 | Top (Sepecify Color) | |
| | 2101-04 | Flip Door (Sepecify Color) | |
| | 2101-05 | Key Commponents | |
| | 2101-06 | Parts Package Components | |
| 2102 | 2101-01 | Door Plank (Sepecify Color) | 52 |
| | 2101-02 | Base (Sepecify Color) | |
| | 2102-01 | Top (Sepecify Color) | |
| | 2101-04 | Flip Door (Sepecify Color) | |
| | 2101-05 | Key Commponents | |
| | 2101-06 | Parts Package Components | |
| 2102-02 | | Ashtray | |
| | | | |
| 2103 | 2101-01 | Door Plank (Sepecify Color) | 52 |
| | 2101-02 | Base (Sepecify Color) | |
| | 2103-01 | Top (Sepecify Color) | |
| | 2101-04 | Flip Door (Sepecify Color) | |
| | 2101-05 | Key Commponents | |
| | 2101-06 | Parts Package Components | |
| 2104 | 2101-01 | Door Plank (Sepecify Color) | 38 |
| | 2101-02 | Base (Sepecify Color) | |
| | 2101-03 | Top (Sepecify Color) | |
| | 2104-01 | Flip Door (Sepecify Color) | |
| | 2101-05 | Key Commponents | |
| | 2101-06 | Parts Package Components | |
| 2105 | 2101-01 | Door Plank (Sepecify Color) | 38 |
| | 2101-02 | Base (Sepecify Color) | |
| | 2101-03 | Top (Sepecify Color) | |
| | 2105-01 | Flip Door (Sepecify Color) | |
| | 2101-05 | Key Commponents | |
| | 2101-06 | Parts Package Components | |
| 2106 | 2106-01 | Door Plank (Sepecify Color) | 52 |
| | 2106-02 | Base (Sepecify Color) | |
| | 2106-03 | Top (Sepecify Color) | |

| Fits | Part Number | Part Description | Page |
|---------|-------------|--------------------------------|--------|
| 2016 | 2106-04 | Flip Door (Sepecify Color) | 52 |
| | 2101-05 | Key Commponents | |
| | 2101-06 | Parts Package Components | |
| 2107 | 2106-01 | Door Plank (Sepecify Color) | 52 |
| | 2106-02 | Base (Sepecify Color) | |
| | 2107-01 | Top (Sepecify Color) | |
| | 2106-04 | Flip Door (Sepecify Color) | |
| | 2101-05 | Key Commponents | |
| | 2101-06 | Parts Package Components | |
| 2107-02 | | Ashtray | |
| | | | |
| 2211 | 2211-01 | Key Commponents (with Brush) | 55 |
| | 2211-02 | Special Wrench | |
| 2212 | 2211-01 | Key Commponents (with Brush) | 56 |
| | 2211-02 | Special Wrench | |
| 2221 | 2211-01 | Key Commponents (with Brush) | 55 |
| | 2211-02 | Special Wrench | |
| 2231 | 2211-01 | Key Commponents (with Brush) | 56 |
| | 2211-02 | Special Wrench | |
| 2241 | 2211-01 | Key Commponents (with Brush) | 56 |
| | 2211-02 | Special Wrench | |
| 2242 | 2211-01 | Key Commponents (with Brush) | 56 |
| | 2211-02 | Special Wrench | |
| 2251 | 2251-01 | Trash Barrel | 57 |
| | 2251-02 | Cigarette Butts Liner | |
| | 2251-03 | Cigarette Butts Cover | |
| 2261 | 2211-01 | Key Commponents (with Brush) | 55 |
| | 2261-01 | Cigarette Butts Liner | |
| 2271 | 2211-01 | Key Commponents (with Brush) | 55 |
| | 2271-01 | Cigarette Butts Liner | |
| 2281 | 2211-01 | Key Commponents (with Brush) | 55 |
| 2291 | 2211-01 | Key Commponents (with Brush) | 55 |
| | 2291-01 | Rain Cover | |
| 2300 | 2300-01 | Ashtray | 58 |
| 2301 | 2301-01 | Ashtray | 58 |
| 2302 | 2302-01 | Ashtray | 58 |
| 2303 | 2301-01 | Ashtray | 58 |
| 2304 | 2300-01 | Ashtray | 58 |
| 2305 | 2302-01 | Ashtray | 58 |
| 2310 | 2300-01 | Ashtray | 45, 58 |
| | 2310-01 | 13.2 L Steel Galvanized Barrel | |
| 2311 | 2301-01 | Ashtray | 45, 58 |
| | 2310-01 | 13.2 L Steel Galvanized Barrel | |
| 2312 | 2302-01 | Ashtray | 45, 58 |
| | 2310-01 | 13.2 L Steel Galvanized Barrel | |
| 2313 | 2301-01 | Ashtray | 47, 58 |
| | 2310-01 | 13.2 L Steel Galvanized Barrel | |
| 2314 | 2300-01 | Ashtray | 46, 58 |
| | 2310-01 | 13.2 L Steel Galvanized Barrel | |
| 2315 | 2302-01 | Ashtray | 46, 58 |
| | 2310-01 | 13.2 L Steel Galvanized Barrel | |
| 2320 | 2320-01 | 56.8 L Steel Galvanized Barrel | 45 |
| 2321 | 2320-01 | 56.8 L Steel Galvanized Barrel | 45 |
| 2322 | 2320-01 | 56.8 L Steel Galvanized Barrel | 45 |
| 2323 | 2320-01 | 56.8 L Steel Galvanized Barrel | 47 |

COMPONENT INDEX

| Fits | Part Number | Part Description | Page |
|------|-------------|--------------------------------|----------------------|
| 2324 | 2320-01 | 56.8 L Steel Galvanized Barrel | 46 |
| 2325 | 2320-01 | 56.8 L Steel Galvanized Barrel | 46 |
| 2330 | 2330-01 | Ashtray | 45, 58 |
| | 2330-02 | 45.4 L Steel Galvanized Barrel | |
| 2331 | 2331-01 | Ashtray | 45, 58 |
| | 2330-02 | 45.4 L Steel Galvanized Barrel | |
| 2332 | 2332-01 | Ashtray | 45, 58 |
| | 2330-02 | 45.4 L Steel Galvanized Barrel | |
| 2333 | 2331-01 | Ashtray | 47, 58 |
| | 2330-02 | 45.4 L Steel Galvanized Barrel | |
| 2334 | 2330-01 | Ashtray | 46, 58 |
| | 2330-02 | 45.4 L Steel Galvanized Barrel | |
| 2335 | 2332-01 | Ashtray | 46, 58 |
| | 2330-02 | 45.4 L Steel Galvanized Barrel | |
| 2340 | 2330-02 | 45.4 L Steel Galvanized Barrel | 45 |
| 2341 | 2330-02 | 45.4 L Steel Galvanized Barrel | 45 |
| 2342 | 2330-02 | 45.4 L Steel Galvanized Barrel | 45 |
| 2343 | 2330-02 | 45.4 L Steel Galvanized Barrel | 47 |
| 2344 | 2330-02 | 45.4 L Steel Galvanized Barrel | 46 |
| 2345 | 2330-02 | 45.4 L Steel Galvanized Barrel | 46 |
| 2350 | 2330-02 | 45.4 L Steel Galvanized Barrel | 45 |
| 2351 | 2330-02 | 45.4 L Steel Galvanized Barrel | 45 |
| 2352 | 2330-02 | 45.4 L Steel Galvanized Barrel | 45 |
| 2353 | 2330-02 | 45.4 L Steel Galvanized Barrel | 47 |
| 2354 | 2330-02 | 45.4 L Steel Galvanized Barrel | 46 |
| 2355 | 2330-02 | 45.4 L Steel Galvanized Barrel | 46 |
| 2360 | 2320-01 | 56.8 L Steel Galvanized Barrel | 45 |
| 2361 | 2320-01 | 56.8 L Steel Galvanized Barrel | 45 |
| 2362 | 2320-01 | 56.8 L Steel Galvanized Barrel | 45 |
| 2363 | 2320-01 | 56.8 L Steel Galvanized Barrel | 47 |
| 2364 | 2320-01 | 56.8 L Steel Galvanized Barrel | 46 |
| 2365 | 2320-01 | 56.8 L Steel Galvanized Barrel | 46 |
| 3511 | 3511-05 | Partition | 171 |
| | 3511-04 | Transparent Cover | |
| | 3511-01 | Box | |
| | 3511-02 | Lid | |
| | 3511-03 | Inner Box | |
| 3512 | 3511-05 | Partition | 171 |
| | 3511-04 | Transparent Cover | |
| | 3511-01 | Box | |
| | 3511-02 | Lid | |
| | 3511-03 | Inner Box | |
| 3711 | 3711-01 | Supporting Base-Left | 170 |
| | 3711-02 | Supporting Base-Right | |
| | 3711-03 | Cover | |
| | 4021-01 | Bottom Shelf (Specify Color) | |
| | 4021-02 | Middle Shelf (Specify Color) | |
| | 4021-03 | Top Shelf (Specify Color) | |
| | 176204 | 280 mm Aluminum Extrusion | |
| | 3712 | 3711-01 | Supporting Base-Left |
| 3712 | 3711-02 | Supporting Base-Right | |
| | 3711-03 | Cover | |
| | 4021-01 | Bottom Shelf (Specify Color) | |
| | 4021-02 | Middle Shelf (Specify Color) | |
| | 4021-03 | Top Shelf (Specify Color) | |

| Fits | Part Number | Part Description | Page | |
|--------|-------------------------------------|-------------------------------------|------------------------------|----------|
| 3712 | 4021-03 | Top Shelf (Specify Color) | 170 | |
| | 176204 | 280 mm Aluminum Extrusion | | |
| 3713 | 3711-01 | Supporting Base-Left | 170 | |
| | 3711-02 | Supporting Base-Right | | |
| | 3711-03 | Cover | | |
| | 4021-01 | Bottom Shelf (Specify Color) | | |
| | 4021-02 | Middle Shelf (Specify Color) | | |
| | 4021-03 | Top Shelf (Specify Color) | | |
| 3714 | 176206 | 486 mm Aluminum Extrusion | | |
| | 3711-01 | Supporting Base-Left | 170 | |
| 3714 | 3711-02 | Supporting Base-Right | | |
| | 3711-03 | Cover | | |
| | 4021-01 | Bottom Shelf (Specify Color) | | |
| | 4021-02 | Middle Shelf (Specify Color) | | |
| | 4021-03 | Top Shelf (Specify Color) | | |
| | 176205 | 355 mm Aluminum Extrusion | | |
| | 3715 | 3711-01 | Supporting Base-Left | 170 |
| | 3711-02 | Supporting Base-Right | | |
| 3715 | 3711-03 | Cover | | |
| | 4021-01 | Bottom Shelf (Specify Color) | | |
| | 4021-02 | Middle Shelf (Specify Color) | | |
| | 4021-03 | Top Shelf (Specify Color) | | |
| | 176204 | 280 mm Aluminum Extrusion | | |
| | 3716 | 3711-03 | Cover | 170 |
| | 4021-01 | Bottom Shelf (Specify Color) | | |
| | 4021-02 | Middle Shelf (Specify Color) | | |
| 3716 | 4021-03 | Top Shelf (Specify Color) | | |
| | 176204 | 280 mm Aluminum Extrusion | | |
| | 176613 | 10 cm Dia Swivel Caster | | |
| | 3717 | 3711-03 | Cover | 170 |
| | 4021-01 | Bottom Shelf (Specify Color) | | |
| | 4021-02 | Middle Shelf (Specify Color) | | |
| | 4021-03 | Top Shelf (Specify Color) | | |
| | 176206 | 496 mm Aluminum Extrusion | | |
| 3718 | 176613 | 10 cm Dia Swivel Caster with Sleeve | | |
| | 4024-01 | Right Door with Lock | 170 | |
| 3718 | 4024-02 | Left Door | | |
| | 3719 | 4023-01 | Back Pannel (Specify Color) | 170 |
| 3719 | 4023-02 | Side Pannel (Specify Color) | | |
| | 4010 | 4011-01 | Bottom Shelf (Specify Color) | 164, 232 |
| 4010 | 4011-03 | Top Shelf (Specify Color) | | |
| | 4011-04 | Handle (Specify Color) | | |
| | 176613 | 10 cm Dia Swivel Caster with Sleeve | | |
| | 4010-01 | 620 mm Aluminum Extrusion | | |
| | 4011 | 4011-01 | Bottom Shelf (Specify Color) | 164, 232 |
| | 4011-02 | Middle Shelf (Specify Color) | | |
| | 4011-03 | Top Shelf (Specify Color) | | |
| | 4011-04 | Handle (Specify Color) | | |
| 176613 | 10 cm Dia Swivel Caster with Sleeve | | | |
| 4011 | 4011-06 | 280 mm Aluminum Extrusion | | |
| | 4012 | 4011-01 | Bottom Shelf (Specify Color) | 164 |
| 4012 | 4011-02 | Middle Shelf (Specify Color) | | |
| | 4011-03 | Top Shelf (Specify Color) | | |
| | 4013-02 | Side Pannel (Specify Color) | | |

| Fits | Part Number | Part Description | Page | | |
|---------|-------------|-------------------------------------|----------|------------------------------|-----|
| 4012 | 4011-04 | Handle (Specify Color) | 164 | | |
| | 176613 | 10 cm Dia Swivel Caster with Sleeve | | | |
| | 176204 | 280 mm Aluminum Extrusion | | | |
| 4013 | 4011-01 | Bottom Shelf (Specify Color) | 164 | | |
| | 4011-02 | Middle Shelf (Specify Color) | | | |
| | 4011-03 | Top Shelf (Specify Color) | | | |
| | 4011-04 | Handle (Specify Color) | | | |
| | 176613 | 10 cm Dia Swivel Caster with Sleeve | | | |
| | 176204 | 280 mm Aluminum Extrusion | | | |
| | 4013-01 | Back Pannel (Specify Color) | | | |
| | 4013-02 | Side Pannel (Specify Color) | | | |
| | 4013-03 | Left Door | | | |
| 4013-04 | Right Door | | | | |
| 4021 | 4021-01 | Bottom Shelf (Specify Color) | 165, 232 | | |
| | 4021-02 | Middle Shelf (Specify Color) | | | |
| | 4021-03 | Top Shelf (Specify Color) | | | |
| | 4221-04 | Handle (Specify Color) | | | |
| | 176613 | 10 cm Dia Swivel Caster | | | |
| | 176204 | 280 mm Aluminum Extrusion | | | |
| 4022 | 4021-01 | Bottom Shelf (Specify Color) | 165 | | |
| | 4021-02 | Middle Shelf (Specify Color) | | | |
| | 4021-03 | Top Shelf (Specify Color) | | | |
| | 4021-04 | Handle (Specify Color) | | | |
| | 4023-02 | Side Pannel (Specify Color) | | | |
| | 176613 | 10 cm Dia Swivel Caster with Sleeve | | | |
| 4023 | 4021-01 | Bottom Shelf (Specify Color) | 165, 232 | | |
| | 4021-02 | Middle Shelf (Specify Color) | | | |
| | 4021-03 | Top Shelf (Specify Color) | | | |
| | 4021-04 | Handle (Specify Color) | | | |
| | 4023-01 | Back Pannel (Specify Color) | | | |
| | 4023-02 | Side Pannel (Specify Color) | | | |
| | 176613 | 10 cm Dia Swivel Caster | | | |
| | 176204 | 280 mm Aluminum Extrusion | | | |
| | 4024 | 4021-01 | | Bottom Shelf (Specify Color) | 165 |
| | | 4021-02 | | Middle Shelf (Specify Color) | |
| 4021-03 | | Top Shelf (Specify Color) | | | |
| 4021-04 | | Handle (Specify Color) | | | |
| 4023-01 | | Back Pannel (Specify Color) | | | |
| 4023-02 | | Side Pannel (Specify Color) | | | |
| 4851-01 | | Drawer (Specify Color) | | | |
| 176613 | | 10 cm Dia Swivel Caster | | | |
| 176204 | | 280 mm Aluminum Extrusion | | | |
| 4025 | 4024-01 | Right Door with Lock | 165 | | |
| | 4024-02 | Left Door | | | |
| 4025 | 4021-01 | Bottom Shelf (Specify Color) | 165 | | |
| | 4021-02 | Middle Shelf (Specify Color) | | | |
| | 4021-03 | Top Shelf (Specify Color) | | | |
| | 4021-04 | Handle (Specify Color) | | | |
| | 4023-01 | Back Pannel (Specify Color) | | | |
| | 4023-02 | Side Pannel (Specify Color) | | | |
| | 4024-01 | Right Door with Lock | | | |
| | 4024-02 | Left Door | | | |
| | 176613 | 10 cm Dia Swivel Caster | | | |

| Fits | Part Number | Part Description | Page |
|---------|----------------------------------|----------------------------------|------|
| 4025 | 176204 | 280 mm Aluminum Extrusion | 165 |
| 4026 | 4021-01 | Bottom Shelf (Specify Color) | 165 |
| | 4021-02 | Middle Shelf (Specify Color) | |
| | 4021-03 | Top Shelf (Specify Color) | |
| | 4021-04 | Handle (Specify Color) | |
| | 176613 | 10 cm Dia Swivel Caster | |
| | 176204 | 280 mm Aluminum Extrusion | |
| 4027 | 4021-01 | Bottom Shelf (Specify Color) | 165 |
| | 4021-02 | Middle Shelf (Specify Color) | |
| | 4021-03 | Top Shelf (Specify Color) | |
| | 4021-04 | Handle (Specify Color) | |
| | 4023-01 | Back Pannel (Specify Color) | |
| | 4023-02 | Side Pannel (Specify Color) | |
| | 4024-01 | Right Door with Lock | |
| | 4024-02 | Left Door | |
| | 176613 | 10 cm Dia Swivel Caster | |
| | 176204 | 280 mm Aluminum Extrusion | |
| 4031 | 4031-01 | Top Shelf(Specify Color) | 146 |
| | 4031-02 | Right Pannel(Specify Color) | |
| | 4031-03 | Left Pannel(Specify Color) | |
| | 4031-04 | Bottom Shelf | |
| | 4031-05 | Middle Shelf | |
| | 4031-06 | Handle | |
| | 4031-07 | Drawer Pannel | |
| | 4031-08 | Back Pannel | |
| | 4031-09 | Adjustable Shelf | |
| | 4031-10 | Left Hinge | |
| | 4031-11 | Right Hinge | |
| | 4031-12 | Right Door | |
| | 476620 | 12.7 cm dia Rigid Caster | |
| | 176619 | 12.7 cm dia Swivel Caster w/Lock | |
| 176981 | 560 mm Drawer Guaide | | |
| 4031-13 | Metal Drawer | | |
| 4031-14 | Lock Assembly | | |
| 4032 | 4031-01 | Top Shelf(Specify Color) | 146 |
| | 4031-02 | Right Pannel(Specify Color) | |
| | 4031-03 | Left Pannel(Specify Color) | |
| | 4031-04 | Bottom Shelf | |
| | 4031-05 | Middle Shelf | |
| | 4031-06 | Handle | |
| | 4031-08 | Back Pannel | |
| | 4031-09 | Adjustable Shelf | |
| | 4031-10 | Left Hinge | |
| | 4031-11 | Right Hinge | |
| | 4031-12 | Right Door with Lock | |
| | 4032-01 | Left Door | |
| 176620 | 12.7 cm dia Rigid Caster | | |
| 176619 | 12.7 cm dia Swivel Caster w/Lock | | |
| 4033 | 4031-01 | Top Shelf | 146 |
| | 4031-02 | Right Door | |
| | 4031-03 | Left Door | |
| | 4031-04 | Bottom Shelf | |
| | 4031-05 | Middle Shelf | |
| | 4031-06 | Handle | |

COMPONENT INDEX

| Fits | Part Number | Part Description | Page |
|---------|-------------|---------------------------------|----------|
| 4033 | 4031-07 | Drawer Pannel | 146 |
| | 4031-08 | Back Pannel | |
| | 176620 | 12.7 cm dia Rigid Caster | |
| | 176619 | 12.7cm dia Swivel Caster w/Lock | |
| | 176981 | 560 mm Drawer Guaide | |
| | 4031-14 | Metal Drawer | |
| 4041 | 4041-01 | Top Shelf (Specify Color) | 147, 236 |
| | 4041-02 | Bottom Shelf (Specify Color) | |
| | 4041-03 | Right Pillar (specify color) | |
| | 4041-04 | Left Pillar (specify color) | |
| | 4041-05 | Handle (Specify Color) | |
| 4042 | 4041-01 | Top Shelf (Specify Color) | 147 |
| | 4041-02 | Bottom Shelf (Specify Color) | |
| | 4041-03 | Right Pillar (specify color) | |
| | 4041-04 | Left Pillar (specify color) | |
| | 4041-05 | Handle (Specify Color) | |
| | 4042-01 | Drawer Pannel | |
| | 4042-02 | Metal Drawer | |
| 4043 | 4041-01 | Top Shelf (Specify Color) | 147 |
| | 4041-02 | Bottom Shelf (Specify Color) | |
| | 4041-03 | Right Pillar (specify color) | |
| | 4041-04 | Left Pillar (specify color) | |
| | 4041-05 | Handle (Specify Color) | |
| | 4043-01 | Middle Shelf (Specify Color) | |
| 4044 | 4044-01 | Top Shelf (Specify Color) | 147, 236 |
| | 4044-02 | Bottom Shelf (Specify Color) | |
| | 4044-03 | Right Pillar (specify color) | |
| | 4044-04 | Left Pillar (specify color) | |
| | 4041-05 | Handle (Specify Color) | |
| 4045 | 4045-01 | Top Shelf (Specify Color) | 147, 236 |
| | 4044-02 | Bottom Shelf (Specify Color) | |
| | 4041-03 | Right Pillar (specify color) | |
| | 4041-04 | Left Pillar (specify color) | |
| | 4044-05 | Handle (Specify Color) | |
| 4046 | 4044-01 | Top Shelf (Specify Color) | 147 |
| | 4044-02 | Bottom Shelf (Specify Color) | |
| | 4044-03 | Right Pillar (specify color) | |
| | 4044-04 | Left Pillar (specify color) | |
| | 4044-05 | Handle (Specify Color) | |
| | 4046-01 | Middle Shelf (Specify Color) | |
| 4047 | 4045-01 | Top Shelf (Specify Color) | 147 |
| | 4044-02 | Bottom Shelf (Specify Color) | |
| | 4044-03 | Right Pillar (specify color) | |
| | 4044-04 | Left Pillar (specify color) | |
| | 4044-05 | Handle (Specify Color) | |
| 4046-01 | 4046-01 | Middle Shelf (Specify Color) | 147 |
| | 4046-01 | Middle Shelf (Specify Color) | |
| | 4046-01 | Middle Shelf (Specify Color) | |
| | 4046-01 | Middle Shelf (Specify Color) | |
| | 4046-01 | Middle Shelf (Specify Color) | |
| | 4046-01 | Middle Shelf (Specify Color) | |
| 4051 | 4051-01 | Bottom Shelf | 148 |
| | 4051-02 | Front cover | |
| | 4051-03 | Center cover | |
| | 4051-04 | Rear cover | |
| | 4051-05 | Middle Shelf | |
| | 4051-06 | Stopper | |
| | 4051-07 | Lid | |

| Fits | Part Number | Part Description | Page |
|------|-------------|------------------------------------|----------|
| 4051 | 4051-08 | Front Steel Frame Welding Assembly | 148 |
| | 4051-09 | Rear Steel Frame Welding Assembly | |
| | 4051-10 | Center Connection Steel Pipe | |
| | 4051-11 | Bottom Connection Steel Pipe | |
| | 176619 | 12.7 cm dia Swivel Caster w/Lock | |
| | 176620 | 12.7 cm dia Rigid Caster | |
| 4411 | 4411-01 | Platform | 152, 232 |
| | 176307 | Handle | |
| | 176602 | 15 cm Dia Swivel Caster | |
| | 176601 | 15 cm Dia Rigid Caster | |
| 4412 | 4411-01 | Platform | 152 |
| | 176307 | Handle | |
| | 176604 | 15 cm Dia Swivel Caster | |
| | 176603 | 15 cm Dia Rigid Caster | |
| 4413 | 4413-01 | Platform | 152, 232 |
| | 176307 | Handle | |
| | 176608 | 20 cm Dia Swivel Caster | |
| | 176607 | 20 cm Dia Rigid Caster | |
| 4414 | 4413-01 | Platform | 152 |
| | 176307 | Handle | |
| | 176610 | 20 cm Dia Swivel Caster | |
| | 176609 | 20 cm Dia Rigid Caster | |
| 4415 | 4413-01 | Platform | 152 |
| | 176307 | Handle | |
| | 176610 | 20 cm Dia Swivel Caster | |
| | 176609 | 20 cm Dia Rigid Caster | |
| 4416 | 4416-01 | Platform | 152 |
| | 4416-02 | Handle | |
| | 176608 | 20 cm Dia Swivel Caster | |
| | 176607 | 20 cm Dia Rigid Caster | |
| 4417 | 4416-01 | Platform | 152 |
| | 4416-02 | Handle | |
| | 176610 | 20 cm Dia Swivel Caster | |
| | 176609 | 20 cm Dia Rigid Caster | |
| 4418 | 4416-01 | Platform | 152 |
| | 4416-02 | Handle | |
| | 176612 | 20 cm Dia Swivel Caster | |
| | 176611 | 20 cm Dia Rigid Caster | |
| 4461 | 4411-01 | Platform | 156 |
| | 4461-01 | Front Fence | |
| | 4461-02 | Side Fence | |
| | 176601 | 15 cm Dia Rigid Caster | |
| 4462 | 176602 | 15 cm Dia Swivel Caster | 156 |
| | 4413-01 | Platform | |
| | 4462-01 | Front Fence | |
| | 4462-02 | Side Fence | |
| 4463 | 176609 | 20 cm Dia Rigid Caster | 156 |
| | 176610 | 20 cm Dia Swivel Caster | |
| | 4413-01 | Platform | |
| | 4462-01 | Front Fence | |
| 4464 | 4462-02 | Side Fence | 156 |
| | 176607 | 20 cm Dia Rigid Caster | |
| | 176608 | 20 cm Dia Swivel Caster | |
| | 4416-01 | Platform | |

| Fits | Part Number | Part Description | Page |
|------|-------------|---------------------------------------|---------------|
| 4464 | 4464-01 | Front Fence | 156 |
| | 4464-02 | Side Fence | |
| | 176609 | 20 cm Dia Rigid Caster | |
| | 176610 | 20 cm Dia Swivel Caster | |
| 4465 | 4416-01 | Platform | 156 |
| | 4464-01 | Front Fence | |
| | 4464-02 | Side Fence | |
| | 176607 | 20 cm Dia Rigid Caster | |
| | 176608 | 20 cm Dia Swivel Caster | |
| 4471 | 4411-01 | Platform | 155 |
| | 4471-01 | Supporting Base | |
| | 4471-02 | Steel Components | |
| | 176607 | 20 cm Dia Rigid Caster | |
| 4472 | 4413-01 | Platform | 155 |
| | 4471-01 | Supporting Base | |
| | 4472-01 | Steel Components | |
| | 176607 | 20 cm Dia Rigid Caster | |
| 4473 | 441601 | Platform | 155 |
| | 4471-01 | Supporting Base | |
| | 4473-01 | Steel Components | |
| | 176607 | 20 cm Dia Rigid Caster | |
| 4474 | 4474-01 | Handle | 155 |
| | 4474-02 | 20 cm Dia Single Caster | |
| 4481 | 4481-01 | Platform | 156, 238 |
| | 4481-02 | Handle | |
| | 176625 | 7.6 cm Dia Swivel Caster with Sleeve | |
| 4482 | 4481-01 | Platform | 156, 238 |
| | 4481-02 | Handle | |
| | 4482-01 | 10 cm Dia Swivel Caster | |
| 4483 | 4483-01 | Body | 157, 171, 186 |
| | 176640 | 10 cm TPR Flat Bottom Universal Wheel | |
| 4484 | 4484-01 | Body | 238, 251 |
| | 176613 | 10 cm Dia Swivel Caster with Sleeve | |
| 4485 | 4484-01 | Body | 238, 251 |
| | 176613 | 10 cm Dia Swivel Caster with Sleeve | |
| | 4485-01 | Handle | |
| 4491 | 4491-01 | Pad | 175, 185 |
| | 4492-02 | Supporting Base | |
| 4492 | 4492-01 | Pad (122x91 cm) | 175, 185 |
| | 4492-02 | Supporting Base | |
| 4493 | 4493-01 | Pad | 175, 185 |
| | 4492-02 | Supporting Base | |
| 4512 | 4512-02 | 10 cm Swivel Caster | 160 |
| 4522 | 4522-01 | Body Skeleton | 160 |
| | 4522-02 | Body Handle | |
| | 4522-03 | 30 cm Dia Wheel | |
| | 4522-04 | 12.5 cm Dia Swivel Caster | |
| 4532 | 4522-01 | Body Skeleton | 160 |
| | 4522-02 | Body Handle | |
| | 4522-03 | 30 cm Dia Wheel | |
| | 4532-02 | 12.5 cm Dia Swivel Caster | |
| | 4532-03 | Bolt Kits | |
| 4542 | 4542-01 | Body Skeleton | 161 |

| Fits | Part Number | Part Description | Page |
|---------|----------------------------|--------------------------------|----------|
| 4542 | 4522-02 | Body Handle | 161 |
| | 4522-03 | 30 cm Dia Wheel | |
| | 4532-02 | 12.5 cm Dia Swivel Caster | |
| 4711 | 176621 | 10 cm Dia Swivel Caster | 158, 187 |
| | 176622 | 10 cm Dia Rigid Caster | |
| | 176319 | Backplane Supporting Base | |
| | 176320 | Backplane | |
| 4712 | 176621 | 10 cm Dia Swivel Caster | 158 |
| | 176622 | 10 cm Dia Rigid Caster | |
| | 176319 | Backplane Supporting Base | |
| | 176320 | Backplane | |
| 4714 | 4712-01 | Steel Frame | 158, 187 |
| | 176621 | 10 cm Dia Swivel Caster | |
| | 176622 | 10 cm Dia Rigid Caster | |
| 5011 | 4714-02 | Backplane Supporting Base | 76 |
| | 4714-03 | Backplane | |
| | 5011-01 | Bottom Shelf | |
| 5011 | 5011-02 | Middle Shelf | 76 |
| | 5011-03 | Top Shelf | |
| | 5011-04 | Handle | |
| | 5011-05 | Rear Pillar | |
| | 5011-06 | Left Side of Pillar | |
| | 5011-07 | Right Side of Pillar | |
| | 176613 | 10 cm Dia Swivel Caster | |
| 5019 | 5019-01 | Front Pannel | 77 |
| | 5019-02 | Left Pannel | |
| | 5019-03 | Right Pannel | |
| | 5019-04 | Back Pannel | |
| | 5019-05 | Key Compponents | |
| 5021 | 5021-01 | Top Shelf (Specify Color) | 68 |
| | 5021-02 | Bottom Shelf(Specify Color) | |
| | 5021-03 | Side Plate A (Specify Color) | |
| | 5021-04 | Side Plate B (Specify Color) | |
| | 5021-05 | Middle Shelf (Specify Color) | |
| | 5021-06 | Bottom Plate (Specify Color) | |
| | 5021-07 | Backplane(Specify Color) | |
| | 176768 | Vacuum Shelf Components | |
| | 176769 | Garbage Bag Buckle | |
| | 5021-08 | Crash Wheel Assembly | |
| | 176615 | 20 cm Dia Swivel Caster w/Lock | |
| 176616 | 20 cm Dia Rigid Caster | | |
| 179714 | Vinyl Bag | | |
| 5021-09 | Kit(including screw,bolts) | | |
| 5022 | 5021-01 | Top Shelf (Specify Color) | 68 |
| | 5021-02 | Bottom Shelf (Specify Color) | |
| | 5021-03 | Side plate A (Specify Color) | |
| | 5021-04 | Side plate B (Specify Color) | |
| | 5021-05 | Middle Shelf (Specify Color) | |
| | 5021-06 | Bottom Pannel (Specify Color) | |
| | 5021-07 | Backplane (Specify Color) | |
| | 176768 | Vacuum Shelf Components | |
| | 176769 | Garbage Bag Buckle | |
| | 5021-08 | Crash Wheel Assembly | |
| | 176615 | 20cm Dia Swivel Caster w/Lock | |

COMPONENT INDEX

| Fits | Part Number | Part Description | Page |
|---------|-----------------------------|----------------------------------|------|
| 5022 | 176616 | 20 cm Dia Rigid Caster | 68 |
| | 179714 | Vinyl Bag | |
| | 5021-09 | Kit (including screw,bolts) | |
| | 5022-01 | Left Door | |
| | 5022-02 | Right Door with Lock | |
| 5023 | 5021-01 | Top Shelf (Specify Color) | 68 |
| | 5021-02 | Bottom Shelf (Specify Color) | |
| | 5021-03 | Side Plate A (Specify Color) | |
| | 5021-04 | Side Plate B (Specify Color) | |
| | 5021-05 | Middle Shelf (Specify Color) | |
| | 5021-06 | Bottom Pannel (Specify Color) | |
| | 5021-07 | Backplane (Specify Color) | |
| | 176768 | Vacuum Shelf Components | |
| | 176769 | Garbage Bag Buckle | |
| | 5021-08 | Crash Wheel Assembly | |
| | 176615 | 20 cm Dia Swivel Caster w/Lock | |
| | 176616 | 20 cm Dia Rigid Caster | |
| | 179714 | Vinyl Bag | |
| | 5021-09 | Kit (including screw,bolts) | |
| | 5022-01 | Left Door | |
| | 5022-02 | Right Door | |
| 5027-01 | Movable Door | | |
| 5027-02 | Security Hood | | |
| 5031 | 5031-01 | Top Shelf (Specify Color) | 70 |
| | 5031-02 | Bottom Shelf (Specify Color) | |
| | 5031-03 | Side Plate A (Specify Color) | |
| | 5031-04 | Side Plate B (Specify Color) | |
| | 5031-05 | Middle Shelf (Specify Color) | |
| | 5031-06 | Backplane (Specify Color) | |
| | 176768 | Vacuum Shelf Components | |
| | 176769 | Garbage Bag Buckle | |
| | 5021-08 | Crash Wheel Assembly | |
| | 176615 | 20 cm Dia Swivel Caster w/Lock | |
| | 176616 | 20 cm Dia Rigid Caster | |
| 5031-07 | Kit (including screw,bolts) | | |
| 5041 | 176641 | 10 cm Dia Swivel Caster | 82 |
| | 179717 | Linen Bag | |
| 5042 | 176641 | 10 cm Dia Swivel Caster | 82 |
| | 5042-01 | Linen Bag | |
| 5051 | 5051-01 | Bottom Shelf(Specify Color) | 70 |
| | 5051-02 | Top Shelf (Specify Color) | |
| | 5051-03 | Left Side Plate (Specify Color) | |
| | 5051-04 | Right Side Plate (Specify Color) | |
| | 5051-05 | Middle Shelf A (Specify Color) | |
| | 5051-06 | Middle Shelf B (Specify Color) | |
| | 5051-07 | Backplane(Specify Color) | |
| | 5051-08 | 18 cm Dia Swivel Caster w/Lock | |
| | 5051-09 | 18 cm Dia Rigid Caster | |
| | 5051-10 | Vinyl Bag | |
| | 5051-11 | Vacuum shelf components | |
| | 5051-12 | Garbage Bag Buckle | |
| | 5051-13 | Crash Wheel Assembly | |
| 5211 | 5211-01 | Body (Specify Color) | 84 |
| | 5211-02 | Base (Specify Color) | |

| Fits | Part Number | Part Description | Page | | |
|---------|-------------|--------------------------------------|------------|--------------------------------------|--------|
| 5211 | 5211-03 | Water Tank | 84 | | |
| | 5211-04 | Bucket (Specify Color) | | | |
| | 5211-05 | Right Cover (Specify Color) | | | |
| | 5211-06 | Left Cover (Specify Color) | | | |
| | 5211-07 | Platen | | | |
| | 5211-08 | Baffle Plate | | | |
| | 5211-09 | Left Rack | | | |
| | 5211-10 | Right Rack | | | |
| | 5211-11 | Left Gear | | | |
| | 5211-12 | Right Gear | | | |
| | 5211-13 | Valve | | | |
| | 5211-14 | Cover for Valve | | | |
| | 5211-15 | Cover Plate | | | |
| | 5211-16 | Handle for Body | | | |
| | 5211-17 | Fastner | | | |
| | 5211-18 | Handle for Pressure Bar | | | |
| | 176416 | Spring | | | |
| | 5221 | 5221-01 | | Body (Specify Color) | 85, 87 |
| 176984 | | Handle for Bucket | | | |
| 176605 | | 7.6 cm Swivel Caster | | | |
| 5223 | 5223-01 | Body (Specify Color) | 85 | | |
| | 5223-02 | Squeeze Water Basket (Specify Color) | | | |
| | 5223-03 | Squeeze Water Plate (Specify Color) | | | |
| | 5223-04 | Fixed Part-Left | | | |
| | 5223-05 | Fixed Part-Right | | | |
| | 5223-06 | Handle | | | |
| | 176344 | Strut Components | | | |
| | 176417 | Torsion Spring | | | |
| | 176984 | Handle for Bucket | | | |
| | 176605 | 7.6 cm Swivel Caster | | | |
| 5224 | 5224-01 | Body (Specify Color) | 85, 86, 87 | | |
| | 176356 | Handle for Bucket | | | |
| | 176605 | 7.6 cm Swivel Caster | | | |
| 5226 | 5226-01 | Body (Specify Color) | 85 | | |
| | 5226-02 | Squeeze Water Basket (Specify Color) | | | |
| | 5226-03 | Squeeze Water Plate (Specify Color) | | | |
| | 176354 | Strut Components | | | |
| | 176355 | Torsion Spring | | | |
| | 176356 | Handle for Bucket | | | |
| | 176605 | 7.6 cm Swivel Caster | | | |
| | 5228 | 5226-01 | | Body (Specify Color) | 86 |
| | | 5227-01 | | Squeeze Water Basket (Specify Color) | |
| | | 5227-02 | | Left Cover (Specify Color) | |
| 5227-03 | | Right Cover (Specify Color) | | | |
| 5227-04 | | Left Rack | | | |
| 5227-05 | | Right Rack | | | |
| 5227-06 | | Gear | | | |
| 5227-07 | | Strut Components | | | |
| 5227-08 | | Torsion Spring | | | |
| 176605 | | 7.6 cm Swivel Caster | | | |
| 5229 | 5229-01 | Body (Specify Color) | 85, 86, 87 | | |
| | 5229-02 | Handle for Bucket | | | |
| | 176605 | 7.6 cm Swivel Caster | | | |
| 5281 | 5281-01 | Bronze Drum | 88 | | |

| Fits | Part Number | Part Description | Page |
|---------|------------------------------------|--------------------------------------|---------|
| 5281 | 5281-02 | Tension Spring | 88 |
| | 5281-03 | Castor Components | |
| 5300 | 5229-01 | Body (Specify Color) | 85 |
| | 5226-02 | Squeeze Water basket (Specify Color) | |
| | 5226-03 | Squeeze Water plate (Specify Color) | |
| | 176354 | Strut Components | |
| | 176355 | Torsion Spring | |
| | 5229-02 | Handle for Bucket | |
| | 176605 | 7.6 cm Swivel Caster | |
| 5301 | 5229-01 | Body (Specify Color) | 86 |
| | 5227-01 | Squeeze Water Basket (Specify Color) | |
| | 5227-02 | Left Cover (Specify Color) | |
| | 5227-03 | Right Cover (Specify Color) | |
| | 5227-04 | Left Rack | |
| | 5227-05 | Right Rack | |
| | 5227-06 | Gear | |
| | 5227-07 | Strut Components | |
| | 5227-08 | Torsion Spring | |
| | 176605 | 7.6 cm Swivel Caster | |
| | 5310 | 5310-01 | Chassis |
| 1813-01 | | 7.5 cm Dia Quiet Caster | |
| 5311 | 5310-01 | Chassis | 87 |
| | 1813-01 | 7.5 cm Dia Quiet Caster | |
| | 5226-01 | Body (Specify Color) | |
| | 5226-02 | Squeeze Water basket (Specify Color) | |
| | 5226-03 | Squeeze Water plate (Specify Color) | |
| | 176354 | Strut Components | |
| | 176355 | Torsion Spring | |
| | 176356 | Handle for Bucket | |
| 5263-01 | Dirty Water Bucket (Specify Color) | | |
| 5312 | 5310-01 | Chassis | 87 |
| | 1813-01 | 7.5 cm Dia Quiet Caster | |
| | 5226-01 | Body (Specify Color) | |
| | 5227-01 | Squeeze Water basket (Specify Color) | |
| | 5227-02 | Left Cover (Specify Color) | |
| | 5227-03 | Right Cover (Specify Color) | |
| | 5227-04 | Left Rack | |
| | 5227-05 | Right Rack | |
| | 5227-06 | Gear | |
| | 5227-07 | Strut Components | |
| | 5227-08 | Torsion Spring | |
| 5263-01 | Dirty Water Bucket (Specify Color) | | |
| 6851 | 6851-01 | Steel Components | 116 |
| 6852 | 6851-01 | Bracket Components | 116 |
| 6853 | 6851-01 | Bracket Components | 117 |
| 6861 | 6861-01 | Broom Connector Components | 116 |
| 6862 | 6861-01 | Connector Components | 116 |
| 6863 | 6861-01 | Connector Components | 117 |
| 6871 | 6851-01 | Steel Components | 116 |
| | 6861-01 | Broom Connector Components | |
| 6872 | 6851-01 | Bracket Components | 116 |
| | 6861-01 | Connector Components | |
| 6873 | 6851-01 | Bracket Components | 117 |
| | 6861-01 | Connector Components | |

| Fits | Part Number | Part Description | Page | |
|---------|-------------|-------------------------------------|-------------------------------|-----|
| 6881 | 6851-01 | Bracket Components | 116 | |
| | 6861-01 | Connector Components | | |
| 6882 | 6851-01 | Bracket Components | 116 | |
| | 6861-01 | Connector Components | | |
| 6883 | 6851-01 | Bracket Components | 117 | |
| | 6861-01 | Connector Components | | |
| 6891 | 6851-01 | Bracket Components | 116 | |
| | 6861-01 | Connector Components | | |
| 6892 | 6851-01 | Bracket Components | 116 | |
| | 6861-01 | Connector Components | | |
| 6893 | 6851-01 | Bracket Components | 117 | |
| | 6861-01 | Connector Components | | |
| 6911 | 6912-01 | Body | 126 | |
| | 6911-01 | Moving Part | | |
| | 6912-04 | Wheel | | |
| | 6912-05 | Handle with Hook | | |
| 6912 | 6912-01 | Body | 126 | |
| | 6912-02 | Activities Cover | | |
| | 6912-03 | Moving Part | | |
| | 6912-04 | Wheel | | |
| | 6912-05 | Handle with Hook | | |
| 6913 | 6912-01 | Body | 126 | |
| | 6912-02 | Activities Cover | | |
| | 6912-03 | Moving Part | | |
| | 6912-04 | Wheel | | |
| | 6913-01 | Handle without Hook | | |
| 6914 | 6912-01 | Body | 126 | |
| | 6911-01 | Moving Part | | |
| | 6912-04 | Wheel | | |
| | 6913-01 | Handle without Hook | | |
| 6932 | 6932-01 | Top of the Pedal (Specify Color) | 134, 174 | |
| | 6932-02 | Left Support Plate (Specify Color) | | |
| | 6932-03 | Right Support Plate (Specify Color) | | |
| | 6932-04 | Non-slip Pad-Left | | |
| | 6932-05 | Non-slip Pad-Right | | |
| 6933 | 6933-01 | Pedal (Specify Color) | 134, 174 | |
| | 6933-02 | Wheel Components | | |
| 8011 | 8011-01 | Seat (Specify Color) | 256 | |
| | 8011-02 | Left Bracket (Specify Color) | | |
| | 8011-03 | Right Bracket (Specify Color) | | |
| | 8011-04 | Bracket Connecting Rod-Front | | |
| | 8011-05 | Bracket Connecting Rod-Rear | | |
| | 8011-06 | Bracket for Sear | | |
| | 161267 | Safety Belt-A | | |
| | 161268 | Safety Belt-B | | |
| | 8012 | 8011-01 | Seat (Specify Color) | 256 |
| | | 8011-02 | Left Bracket (Specify Color) | |
| | | 8011-03 | Right Bracket (Specify Color) | |
| 8011-04 | | Bracket Connecting rod-Front | | |
| 8011-05 | | Bracket Connecting rod-Rear | | |
| 8011-06 | | Bracket for Seat | | |
| 161267 | | Safety Belt-A | | |
| 161268 | | Safety Belt-B | | |
| 176606 | | 5 cm Dia Swivel Caster with Sleeve | | |

COMPONENT INDEX

| Fits | Part Number | Part Description | Page |
|---------|-------------|--------------------------------------|------|
| 8411 | 8411-01 | Body | 184 |
| | 8411-02 | Top | |
| | 8411-03 | Transparent Cover | |
| | 8411-04 | Spoon Rack | |
| | 8411-05 | 7.6 cm Dia Swivel Caster | |
| | 8411-06 | 7.6 cm Dia Rigid Caster | |
| 8412 | 8412-01 | Body | 184 |
| | 8412-02 | Top | |
| | 8412-03 | Transparent cover | |
| | 8411-04 | Spoon Rack | |
| 8412 | 8411-05 | 7.6 cm Dia Swivel Caster | 184 |
| | 8411-06 | 7.6 cm Dia Rigid Caster | |
| 8413 | 8413-01 | Body | 184 |
| | 8413-02 | Top | |
| | 8413-03 | Transparent Cover | |
| | 8411-04 | Spoon Rack | |
| | 8411-05 | 7.6 cm Dia Swivel Caster | |
| | 8411-06 | 7.6 cm Dia Rigid Caster | |
| 8418 | 8418-01 | Top | 185 |
| | 8418-02 | Transparent Cover | |
| | 8418-03 | Divider plate | |
| 8419 | 8419-01 | Top | 185 |
| | 8419-02 | Transparent Cover | |
| | 8419-03 | Divider plate | |
| 8420 | 8420-01 | Top | 185 |
| | 8420-02 | Transparent Cover | |
| | 8420-03 | Divider plate | |
| 8441 | 8441-01 | Body | 255 |
| | 8441-02 | Cover | |
| | 8441-03 | 0.9 L Insert | |
| 8442 | 8441-01 | Body | 255 |
| | 8441-02 | Cover | |
| | 8442-01 | 0.7 L Insert | |
| 8443 | 8441-01 | Body | 255 |
| | 8441-02 | Cover | |
| | 8443-01 | 0.5 L Insert | |
| 8613 | 8613-01 | Storage Rack Body (Specify Color) | 230 |
| | 8613-02 | Top (Specify Color) | |
| | 8613-03 | Round Aluminum Alloy Tube | |
| | 8613-04 | Square Aluminum Alloy Tube | |
| | 8613-05 | D Shape Aluminum Alloy Tube | |
| | 176632 | 12.5 cm Dia TPR Swivel Caster w/Lock | |
| | 176631 | 12.5 cm Dia TPR Swivel Caster | |
| | 8614 | 8613-01 | |
| 8614 | 8613-02 | Top (Specify Color) | 230 |
| | 8614-01 | Round Aluminum Alloy Tube | |
| | 8614-02 | Square Aluminum Alloy Tube | |
| | 8614-03 | D shape Aluminum Alloy Tube | |
| | 176632 | 12.5cm Dia TPR Swivel Caster w/Lock | |
| | 176631 | 12.5cm Dia TPR Swivel Caster | |
| | 8615 | 8613-01 | |
| 8613-02 | | Top (Specify Color) | |
| 8615-01 | | Round Aluminum Alloy Tube | |
| 8615-02 | | Square Aluminum Alloy Tube | |

| Fits | Part Number | Part Description | Page |
|------|-------------|--|----------|
| 8615 | 8615-03 | D Shape Aluminum Alloy Tube | 230 |
| | 176632 | 12.5 cm Dia TPR Swivel Caster w/Lock | |
| | 176631 | 12.5 cm Dia TPR Swivel Caster | |
| 8621 | 8621-01 | Storage Rack Body (Specify Color) | 230 |
| | 8613-02 | Top (Specify Color) | |
| | 8613-03 | Round Aluminum Alloy Tube | |
| | 8613-04 | Square Aluminum Alloy Tube | |
| | 8613-05 | D Shape Aluminum Alloy Tube | |
| | 176632 | 12.5 cm Dia TPR Swivel Caster w/Lock | |
| 8622 | 8621-01 | Storage Rack Body (Specify Color) | 230 |
| | 8613-02 | Top (Specify Color) | |
| | 8614-01 | Round Aluminum Alloy Tube | |
| | 8614-02 | Square Aluminum Alloy Tube | |
| | 8614-03 | D Shape Aluminum Alloy Tube | |
| | 176632 | 12.5 cm Dia TPR Swivel Caster w/Lock | |
| 8651 | 8651-01 | Separation Column (with Bolt Assembly) | 231 |
| | 8651-02 | Knob | |
| | 8651-03 | Dust Cover | |
| | 8651-04 | 12.5 cm Dia Swivel Caster w/Lock | |
| | 8651-05 | 12.5 cm Dia Swivel Caster | |
| 8888 | 8888-01 | Rectangular Chassis | 157, 228 |
| | 176640 | 10 cm TPR Flat Bottom Universal Wheel | |
| 8889 | 8889-01 | Rectangular Chassis | 157, 228 |
| | 176640 | 10 cm TPR Flat Bottom Universal Wheel | |

Stemware and Glass Sizing Reference Guide

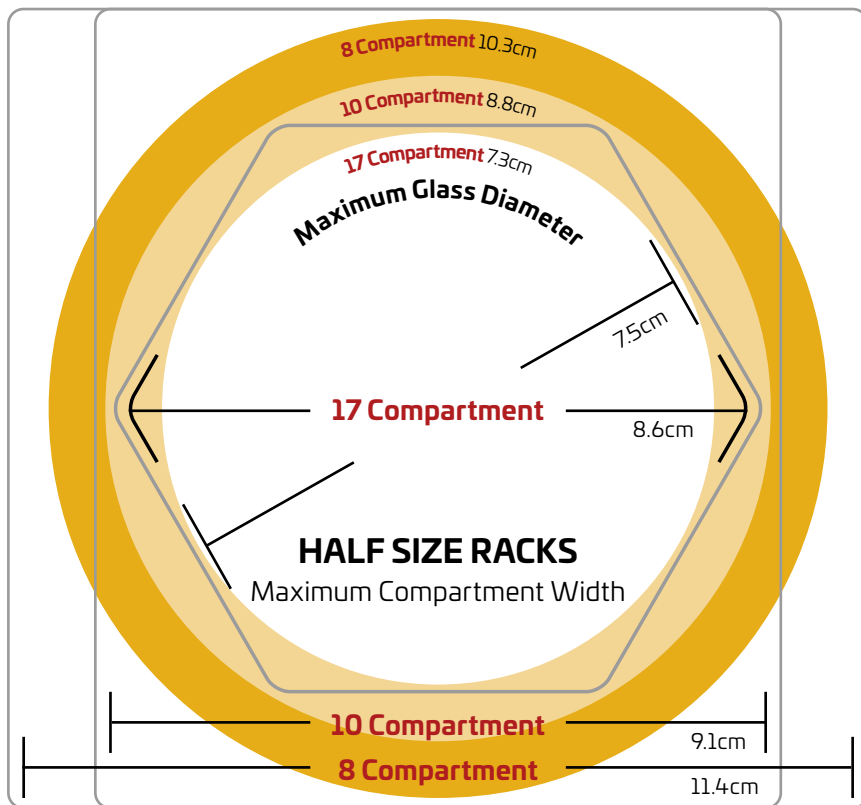

Use the vertical guide on the right to determine item height and the number of extenders that should be used.

Use the two circular guides to determine which rack should be used based on the diameter of the glass or stemware.

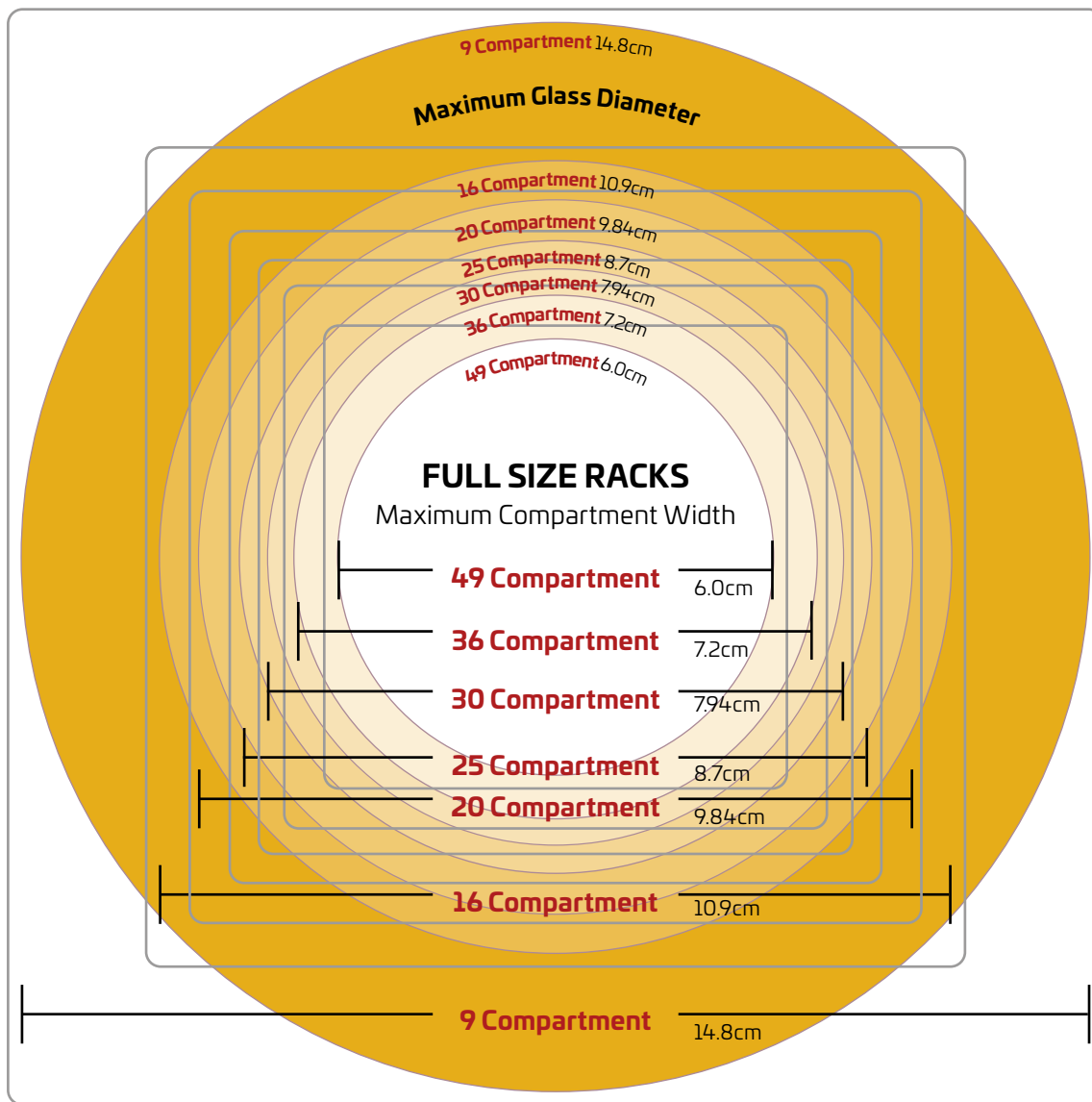

1
(Extenders)

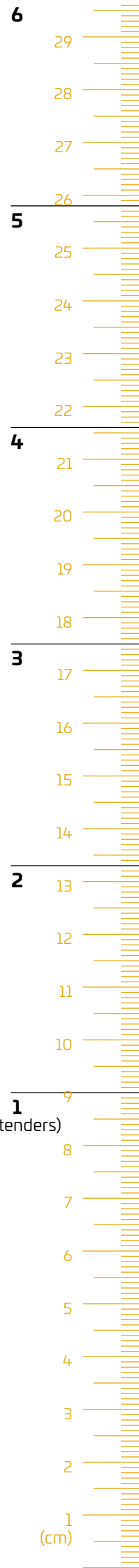

5

4

3

2

1

6



Trust Commercial Products Co.,Ltd

Add: 143 Fanrong Road, Yuanqiao, Huangyan,
Taizhou, Zhejiang, China 318025

Tel: +86 576-8489 9988

Fax: +86 576-8488 9878

info@trustcommercial.com

www.trustcommercial.com

Dealer